

电能质量分析仪
Power quality analyzer
技术说明书
Technical Specification



危险和警告 Danger and Warning

在进行安装、操作或者维护此设备之前，请仔细阅读本手册，通过本手册逐步熟悉设备。本文件不是一本适用于未受训者的操作手册，在其正常使用范围之外所引起的问题，本公司概不负责。

Before installing, operating, or maintaining this equipment, please read this manual carefully and become familiar with the equipment step by step through this manual. This document is not an operation manual suitable for untrained personnel, and our company will not be responsible for any issues arising outside its normal usage scope.



触电、燃烧或者爆炸的危险 Risk of electric shock, combustion, or explosion

- 本设备部分存在电力危险，请严格按照规范进行作业。
- This equipment part poses an electrical hazard, please operate strictly in accordance with the specifications.
- 在维护和检修之前，设备必须断电并接地。
- Before maintenance and repair, the equipment must be powered off and grounded.
- 在设备通电前，应将所有的机械部件，门和盖子等恢复原位。
- Before powering on the equipment, all mechanical components, doors, covers, etc. should be restored to their original positions.
- 设备维护和安装工作只能由有资质的人员执行。
- Equipment maintenance and installation work can only be carried out by qualified personnel.

若不注意这些预防措施可能会引起严重伤害。

Failure to take these preventive measures may lead to serious injuries.

目 录 Content

第一章 产品介绍 Chapter 1 Product Introduction	1
1.1 概述 Overview	1
1.2 功能介绍 Function Introduction	3
第二章 技术指标 Chapter 2 Technical Indicators	6
2.1 测量精度 Measurement accuracy	6
2.2 环境条件和电源 Environmental conditions and power supply	6
2.3 电压电流输入 Voltage and current input	7
2.4 开关量输入 Switching value input	7
2.5 继电器输出 Relay output	7
2.6 EC、秒信输出 EC, Second signal output	7
2.7 通讯 Communication	7
2.8 电气特性 Electrical characteristics	8
2.9 电磁兼 Electromagnetic compatibility	8
第三章 功能介绍 Chapter 3: Function Introduction	10
3.1 测量功能 Measurement function	10
3.1.1 基本测量功能 Basic measurement function	10
3.1.2 频率测量 Frequency measurement	11
3.1.3 功率因数定义方法 Definition method of power factor	11
3.1.4 总视在功率的计算方法 Calculation method of total apparent power	12
3.2 电能计量 Electric energy metering	12
3.2.1 基本电能计量 Basic electric energy metering	12
3.2.2 电能翻转和清零 Electric energy reversal and resetting	13
3.2.3 电能脉冲 Electric energy pulse	13
3.3 需量 Demand	13
3.3.1 实时需量 Real-time demand	13
3.3.2 需量算法 Demand calculation method	14
3.3.3 最大需量 Maximum demand	15
3.4 分时计量 (TOU) 功能 Time-of-Use (TOU) function	15
3.5 稳态电能质量监测功能 Steady-state power quality monitoring function	17
3.5.1 谐波、间谐波监测 Harmonic and inter-harmonic monitoring	17
3.5.2 电压偏差 Voltage deviation	25
3.5.3 频率偏差 Frequency deviation	29
3.5.4 不平衡和序分量测量 Unbalance and sequence component measurement	30
3.5.5 电压波动 Voltage fluctuation	33

3.5.6 电压闪变 Voltage flicker	34
3.5.7 电压快速变动 Rapid voltage variation	39
3.6 暂态电能质量监测功能 Transient power quality monitoring function	42
3.6.1 电压暂升暂降及中断 Voltage dips, spikes, and interruptions	42
3.6.2 电压事件标记 Voltage event marking	43
3.7 瞬态电能质量监测功能 Transient power quality monitoring function	43
3.7.1 瞬态过电压捕捉 Transient overvoltage capture	43
3.7.2 突变量检测 Abrupt change detection	44
3.8 电能质量统计功能 Power quality statistics function	44
3.8.1 统计定时记录 Statistical timing records	44
3.9 越限监测与控制功能 Off-limit monitoring and control function	45
3.9.1 越限监测 Out-of-limit monitoring	45
3.10 事件记录 (SOE) Event recording (SOE)	46
3.10.1 监测事件 Monitoring events	46
3.10.2 装置日志 Device log	47
3.10.3 事件计数 Event Counting	48
3.11 数据记录功能 Data recording function	48
3.11.1 最值功能 Extreme value function	48
3.11.2 电能记录功能 Electric energy recording function	49
3.11.3 PQDIF	49
3.12 波形记录功能 Waveform recording function	50
3.12.1 波形记录 Waveform recording	50
3.12.2 扰动记录 Perturbation record	51
3.12.3 定时录波 Timed wave recording	53
3.12.4 有效值记录 Effective value record	54
3.13 ITIC /SEMI F47 曲线 ITIC /SEMI F47 curve	55
3.14 输入输出功能 Input and output functions	56
3.14.1 开关量输入 Switching value input	56
3.14.2 开关量输出 Switching value output	56
3.14.3 电能脉冲输出 Electric energy pulse output	56
3.14.4 秒脉冲输出 Second pulse output	56
3.15 通信功能 Communication function	57
3.15.1 RS-485 通信 RS-485 communication	57
3.15.2 以太网通信 Ethernet communication	57
3.16 时钟功能 Clock function	57
3.16.1 时钟 Clock	57
3.16.2 对时功能 Time Synchronization Function	57

3.17 USB 功能 USB function	59
3.17.1 USB 升级程序 USB upgrade program	59
第四章 使用与操作 Chapter 4: Usage and Operation	60
4.1 键盘定义 Keyboard definition	60
4.2 脉冲灯定义 Definition of pulse lamp	60
4.3 菜单说明 Menu description	61
4.3.1 基本测量 Basic measurement	62
4.3.2 波形显示 Waveform display	63
4.3.3 电能质量 Power quality	64
4.3.4 电能计量 Electric energy metering	67
4.3.5 需量统计 Demand statistics	69
4.3.6 分时计费 Time-based billing	70
4.3.7 事件记录 Event recording	71
4.3.8 表计状态 Meter status	72
4.3.9 参数设置 Parameter setting	73
第五章 安装 Chapter 5: Installation	82
5.1 安装预防、准备 Installation prevention and preparation	82
5.2 安装信息 Installation Information	82
5.2.1 安装环境和位置 Installation environment and location	82
5.2.2 安装尺寸 (单位: mm; 公差: ± 0.5) Installation dimensions (unit: mm; tolerance: ± 0.5)	83
5.3 端子定义 Terminal definition	84
5.4 接线图纸 Wiring diagram	85
5.4.1 电源 Power supply	85
5.4.2 V 电压电流 Voltage and current	86
5.4.3 通讯 Communication	87
5.4.4 开关输入 Switch input	88
5.4.5 继电器输出 Relay output	88
5.4.6 脉冲端子接线 Pulse terminal wiring	89
5.4.8 PPS 接线 PPS wiring	90
第六章 维护和故障排除 Chapter 6 Maintenance and Troubleshooting	91
6.1 故障排除 Troubleshooting	91
第七章 质量保证 Chapter 7 Quality Assurance	93
7.1 质量保证 Quality Assurance	93
7.2 质量限制 Quality restrictions	93

第一章 产品介绍 Chapter 1 Product Introduction

1.1 概述 Overview

电能质量在线监测装置（以下简称 装置）是自主研发的新一代电能质量在线监测装置。装置具有高精度的测量和计量功能、定时记录及分时计费功能；丰富的电能质量监测功能，装置遵循最新的电能质量七项国家标准和电能质量监测设备通用要求的国家标准，集谐波分析、波形采样、电压暂升/暂降记录、闪变监测、电压不平衡度测量、波形的瞬态捕捉、事件记录、测量控制等多种功能为一体，满足电能质量监测 A 级标准；准确的故障诊断及定位功能，针对供电系统局部异常或局部故障，准确地记录大量波形信息及事件信息，对潜在的、瞬时的、或者持续性的局部故障进行灵敏识别和准确判断，保障用户供电系统的安全、可靠运行。

The power quality online monitoring device (hereinafter referred to as the device or device) is a new generation of power quality online monitoring device independently developed by Guangdong Yada Electronics Co., Ltd. The device features high-precision measurement and metering capabilities, scheduled recording, and time-sharing billing functions; it also boasts a rich set of power quality monitoring functions. The device complies with the latest seven national standards for power quality and the national standards for general requirements of power quality monitoring equipment, integrating harmonic analysis, waveform sampling, voltage sag/swell recording, flicker monitoring, voltage imbalance measurement, transient waveform capture, event recording, measurement control, and other multifunctional features to meet the Class A standard for power quality monitoring. It also possesses accurate fault diagnosis and localization capabilities, accurately recording a large amount of waveform information and event information for local anomalies or faults in the power supply and consumption system. It can sensitively identify and accurately judge potential, transient, or persistent local faults, ensuring the safe and reliable operation of the user's power supply and consumption system.

装置每周波采样 1024 点，高测量精度，全电量测量，具有超大容量数据存储和记录，记录数据可保存半年以上，5.7 寸大屏幕高分辨率 TFT 彩屏液晶显示，采用铝合金高档金属外壳，外观精致美观。

The device samples 1024 points per week, boasts high measurement accuracy, measures all electrical quantities, and features ultra-large capacity data storage and recording. The recorded data can be saved for more than half a year. It is equipped with a 5.7-inch high-resolution TFT color LCD screen and an aluminum alloy high-end metal casing, presenting an exquisite and beautiful appearance.

电能质量在线监测装置按照以下标准执行

The power quality online monitoring device operates in accordance with the following standards

表 1-1 执行标准列表

Table 1-1 List of Implementation Standards

标准号 Standard Number	标准内容 Standard content
GB/T 14549	电能质量 公用电网谐波 Power quality Harmonics in public power grid
GB/T 12325	电能质量 供电电压偏差 Power quality Power supply voltage deviation
GB/T 12326	电能质量 电压波动和闪变 Power quality Voltage fluctuation and flicker
GB/T 15543	电能质量 三相电压不平衡 Power quality Three-phase voltage imbalance
GB/T 15945	电能质量 电力系统频率偏差 Power quality Power system frequency deviation
GB/T 18481	电能质量 暂时过压和瞬态过压

	Power quality: Temporary overvoltage and transient overvoltage
GB/T 24337	电能质量 公用电网间谐波 Power quality Harmonics between utility grids
GB/T 30137	电能质量 电压暂降与短时中断 Power quality: Voltage sag and short interruptions
GB/T 19862	电能质量监测设备通用要求 General requirements for power quality monitoring equipment
GB/T 17626.30	电磁兼容 实验和测量技术 电能质量测量方法 Electromagnetic Compatibility, Experimental and Measurement Technology, Power Quality Measurement Methods
GB/T 17626.7	电磁兼容 试验和测量技术 供电系统及所连设备谐波、间谐波的测量和测量仪器导则 Electromagnetic Compatibility Testing and Measurement Techniques - Guidelines for Harmonic and Interharmonic Measurements and Measuring Instruments for Power Supply Systems and Connected Equipment
GB/T 17626.4	电磁兼容 试验和测量技术 电快速瞬变脉冲群抗扰度试验 Electromagnetic Compatibility - Testing and Measurement Techniques - Electrical Fast Transient/Burst Immunity Test
GB/T 17626.3	电磁兼容 试验和测量技术 射频电磁场辐射抗扰度试验 Electromagnetic Compatibility - Testing and Measurement Techniques - Radiated Radio-frequency Electromagnetic Field Immunity Test
GB/T 17626.2	电磁兼容 试验和测量技术 静电放电抗扰度试验 Electromagnetic Compatibility - Testing and Measurement Techniques - Electrostatic Discharge Immunity Test
GB/T 17626.5	电磁兼容 试验和测量技术 浪涌(冲击)抗扰度试验 Electromagnetic compatibility - Testing and measurement techniques - Surge (impact) immunity test
GB/T 17215.322	交流电测量设备特殊要求 第 22 部分: 静止式有功电能表 (0.2S 级和 0.5S 级) Special Requirements for AC Measurement Equipment - Part 22: Static Active Energy Meters (Class 0.2S and Class 0.5S)
GB/T 17215.302	交流电测量设备特殊要求 第 2 部分: 静止式谐波有功电能表 Special Requirements for AC Measurement Equipment - Part 2: Static Harmonic Active Energy Meters
GB/T 17215.324	交流电测量设备特殊要求 第 24 部分: 静止式基波频率无功电能表(0.5S 级、1S 级和 1 级) Special Requirements for AC Measurement Equipment - Part 24: Static Fundamental Frequency Reactive Energy Meters (Class 0.5S, Class 1S, and Class 1)
GB/T 17215.301	交流电测量设备特殊要求 第 1 部分: 多功能电表 Special Requirements for AC Measurement Equipment - Part 1: Multifunction Electricity Meters
Q/GDW 10650.2	电能质量监测技术规范 第 2 部分: 电能质量监测装置 Technical Specification for Power Quality Monitoring - Part 2: Power Quality Monitoring Devices
Q/GDW 1650.3	电能质量监测技术规范 第 3 部分: 监测终端与主站间通信协议 Technical Specification for Power Quality Monitoring - Part 3: Communication Protocol between Monitoring Terminals and Master Stations
IEC 61000-4-30	电能质量测量方法 Power quality measurement method
IEC 61000-4-15	闪变仪-功能和设计规范 Flicker meter - Functional and design specifications

1.2 功能介绍 Function Introduction

表 1-2 基本功能
Table 1-2 Basic functions

测量通道 Measurement channel	
电压通道数 Number of voltage channels	3
电流通道数 Number of current channels	4
实时测量 real-time measurement	
电流 Current	√
相电压 Phase voltage	√
线电压 Line voltage	√
有功功率 Active power	√
无功功率 Reactive power	√
视在功率 Apparent power	√
功率因数 Power factor	√
频率 Frequency	√
角度 Angle	√
电能计量 electricity metering	
全波电能 Full-wave electric energy	√
基波电能 Fundamental wave electric energy	√
谐波电能 Harmonic electric energy	总谐波电能、2~63 次谐波电能 Total harmonic energy, 2nd to 63rd order harmonic energy
复费率电能 Multi-rate energy	√
需量功能 Demand function	
实时需量 Real-time demand	√
最大需量 Maximum Demand	本次、上 1~上 12 次最大需量 This time, the maximum demand from the 1st to the 12th
复费率功能 (TOU) Time-of-Use (TOU) function	
分时计量 Time-based metering	√
稳态电能质量 Steady-state power quality	
波形采样率 Waveform sampling rate	1024 点/周波 1024 points/cycle
电压偏差 voltage deviation	√
频率偏差 frequency deviation	√
三相不平衡 three-phase unbalance	√
谐波 harmonic	63 次 times
间谐波 interharmonic	63 次 times
电压波动 voltage fluctuation	√

闪变分析 Flicker analysis	√
快速电压变动 Rapid voltage fluctuation	√
暂态电能质量 Transient power quality	
电压暂升 voltage swell	√
电压暂降 voltage sag	√
电压中断 voltage interruption	√
标记功能 Tagging function	√
瞬态电能质量 Transient power quality	
瞬态过电压 transient over-voltage	20μs
突变量检测 Abnormal variable detection	√
电能质量统计与评估 Power quality statistics and evaluation	
统计定时记录 Statistics timing record	√
越限监测与控制 Off-limit monitoring and control	
越限监测 Off-limit monitoring	√
录波记录 waveform recording	
波形记录 waveform recording	√
扰动记录 Disturbance record	√
定时录波 Scheduled wave recording	√
有效值记录 Effective value record	√
事件记录 Event log	
监测事件 (1ms) Monitor event (1ms)	1024 条, 1ms 分辨率 1024 entries, 1ms resolution
装置日志 (1ms) Device log (1ms)	1024 条, 1ms 分辨率 1024 entries, 1ms resolution
事件计数 Event count	√
数据记录 Data recording	
最值记录 Record of maximum value	√
电能记录 Electric energy recording	√
PQDIF	√
显示 display	
显示方式 display mode	彩屏 640×480 5.7 寸 Color screen 640×480, 5.7 inches
实时数据	三相电压、电流、功率、频率等电参量显示

real-time data	Display of electrical parameters such as three-phase voltage, current, power, and frequency
实时告警 Real-time alerts	告警信息提示 Alarm information prompt
设备参数 Equipment parameters	相关设定的参数（通信参数如地址、波特率、校验方式和产品信息） Relevant set parameters (communication parameters such as address, baud rate, check mode, and product information)
显示设置 Display Settings	背光时间可设 Backlight time can be set
输入输出 input	
开关量输入(DI) Digital Input (DI)	6 路（无源接点） 6-way (passive contact)
继电器输出(DO) Relay output (DO)	4 路 4-way
电能脉冲输出(E) Electric energy pulse output (E)	2 路 2-way
秒脉冲输出(SEC) Second pulse output (SEC)	1 路 1-way
PPS 对时接口 PPS timing interface	1 路 1-way
通讯 communication	
RS485	2 路 RS485 接口（Modbus RTU 协议），最大响应时间小于 100ms 2-channel RS485 interface (Modbus RTU protocol), with a maximum response time of less than 100ms
以太网口 Ethernet port	2 路网络通信、RJ45 接口，链路数可设，最大 10 个（Modbus TCP、IEC61850 协议） 2-channel network communication, RJ45 interface, with a configurable number of links up to 10 (Modbus TCP, IEC61850 protocol)
USB 口 USB port	1 个 1 piece
通信规约 communication protocol	Modbus RTU、Modbus TCP、IEC61850 及 GOOSE 协议 Modbus RTU, Modbus TCP, IEC61850, and GOOSE protocols
时钟、计时功能 Clock and timing functions	
时钟 clock	时钟具有自动计算日历、计时、闰年自动转换功能。 The clock has functions such as automatic calendar calculation, timing, and automatic leap year conversion.
对时 time synchronization	Modbus 、SNTP、PPS、IRIG-B Modbus, SNTP, PPS, IRIG-B

第二章 技术指标 Chapter 2 Technical Indicators

2.1 测量精度 Measurement accuracy

参数 Parameter	精度 Accuracy	分辨率 Resolution
电压 Voltage	±0.1%	0.001V
电流 Current	±0.1%	0.001A
电压电流相位 Voltage and current phase	±0.2°	0.1°
频率 Frequency	±0.01Hz	0.001Hz
有功功率 Active power	±0.2%	0.1W
无功功率 Reactive power	±0.2%	0.1var
视在功率 Apparent power	±0.2%	0.1VA
功率因数 Power factor	±0.5%	0.001
电压偏差 Voltage deviation	±0.1%	0.01%
频率偏差 Frequency deviation	±0.01Hz	0.01Hz
三相电压不平衡度 Three-phase voltage imbalance	A 级 Class A	0.01%
三相电流不平衡度 Three-phase current imbalance	A 级 Class A	0.01%
闪变 flicker	A 级 Class A	0.001
电压谐波 Voltage harmonic	A 级 Class A	0.001V
电流谐波 current harmonic	A 级 Class A	0.001A
有功电能 active energy	0.2S 级 Class 0.2S	0.001kWh
无功电能 Reactive energy	1.0 级 Class 1.0	0.001kvarh
时间精度 time precision	外部对时 (±1ms) External timing (±1ms) 无外部对时 (±1s/24h) No external timing (±1s/24h)	1ms

2.2 环境条件和电源 Environmental conditions and power supply

环境条件 Environmental conditions		
储藏温度: -40℃~+70℃ Storage temperature: -40℃~+70℃		工作温度: -25℃~+55℃ Operating temperature: -25℃~+55℃
湿度: 5%~95%, 无冷凝 Humidity: 5%~95%, non-condensing		海拔: ≤2000 米 Altitude: ≤2000 meters
工作电源 working power supply		
最大功耗 Maximum Power Consumption	≤8W	输入: AC85V~AC265V, 50/60Hz or DC100V~DC330V Input: AC85V~AC265V, 50/60Hz or DC100V~DC330V

2.3 电压电流输入 Voltage and current input

电压输入 Voltage input	
标称电压 Un Nominal voltage Un	57.7V/100V 或 or 220V/380V
精度范围 Accuracy range	0.1Un~2Un
频率范围 Frequency range	42.5~57.5Hz
功耗 Power consumption	<0.5VA/相 phase
过载能力 Overload capacity	2Un 连续工作, 4Un, 允许 1s 2Un continuous operation, 4Un, allowed for 1s
信号接入方式 Signal access method	直接接入式、间接接入式 Direct access, indirect access
电流输入 Current input	
额定电流 In Rated current In	5A 或 or 1A
精度范围 precision range	0.01In~1.5In
功率消耗 Power consumption	<0.5VA/相 phase
过载能力 Overload capacity	1.5 倍 In, 连续工作, 10 倍 In 允许 1s 1.5 times In, continuous operation; 10 times In allowed for 1 second
信号接入方式 Signal access method	间接接入式 Indirect access type

备注：超过产品额定范围的电压/电流值会造成仪表损坏。我公司对于超量程导致的精度变化不予负责。

Note: Voltage/current values exceeding the rated range of the product may cause damage to the instrument. Our company will not be responsible for any accuracy changes resulting from exceeding the range.

2.4 开关量输入 Switching value input

开关量输入（6 路 DI）Switching value input (6-channel DI)	
光耦隔离 optocoupler isolation	6 通道 channels
输入类型 input type	干接点(使用 12V 内激励)Dry contact (using 12V internal excitation)

2.5 继电器输出 Relay output

继电器输出（4 路 DO）Relay output (4-channel DO)	
触点类型 Contact type	常开 Normally Open
触点容量(阻性) Contact capacity (resistive)	DC30V, 5A; AC250V, 5A
动作时间 Action Time	≤20ms

2.6 EC、秒信输出 EC, Second signal output

EC 输出（2 路光耦）、秒信号（1 路）EC output (2-channel optocoupler), second signal (1-channel)	
最大电压 Maximum Voltage	30VDC
最大电流 Maximum current	50mA

2.7 通讯 Communication

2 路 RS485 接口 2-channel RS485 interface	
端口类型: RS485, 2 线半双工 Port type: RS485, 2-wire half-duplex	通讯规约: Modbus RTU Communication protocol: Modbus RTU
校验位: 无/奇/偶可选, 默认无校验 Check digit: None/Odd/Even selectable, default is no check digit	通讯波特率: 4800bps、9600bps、19200bps、38400bps、115200 可选, 默认 9600bps Communication baud rate: 4800bps, 9600bps, 19200bps, 38400bps, 115200bps are optional, with a default of 9600bps

2 以太网口 2 Ethernet ports	
端口类型: Ethernet, RJ45 接口 Port type: Ethernet, RJ45 interface	通讯规约: Modbus TCP, IEC61850 Communication protocol: Modbus TCP, IEC61850
通讯波特率 Communication baud rate	10M/100M
链路数(Modbus TCP) Number of links (Modbus TCP)	1~10 可选, 默认 10, 双网口共用 1~10 is optional, default is 10, dual network ports are shared
1 路 USB 接口 1 USB port	
端口类型: USB Port type: USB	

2.8 电气特性 Electrical characteristics

电气特性 Electrical Characteristics	
绝缘电阻: 100MΩ/500V Insulation resistance: 100MΩ/500V	介质强度 (工频耐压) : Dielectric strength (power frequency withstand voltage): 2kV (r.m.s), 50Hz, 1min (电压、电流、电源、DO、大地, 各组之间) 2kV (r.m.s), 50Hz, 1min (voltage, current, power supply, DO, earth, between each group) 1kV (r.m.s), 50Hz, 1min (DI 输入、RS485 端口、大地, 各组之间) 1kV (r.m.s), 50Hz, 1min (DI input, RS485 port, ground, between each group)
冲击电压 impulse voltage	冲击波形: 1.2/50 s 500Ω Surge waveform: 1.2/50 μs 500Ω 5kV (电压、电流、电源、DO、大地, 各组之间) 5kV (voltage, current, power supply, DO, ground, between each group) 2kV (DI 输入、RS485 端口、大地, 各组之间) 2kV (DI input, RS485 port, ground, between each group)

2.9 电磁兼容 Electromagnetic compatibility

电磁兼容 Electromagnetic Compatibility	
电快速瞬变脉冲群抗扰度试验 Electrical Fast Transient/Burst (EFT/B) Immunity Test	执行标准 GB/T 17626.4: IEC 61000-4-4 Comply with standards GB/T 17626.4 and IEC 61000-4-4 等级: IV级 (其他端口 2kV, 电源端口 4kV) Level: Level IV (2kV for other ports, 4kV for power ports)
静电放电抗扰度试验 Electrostatic discharge immunity test	执行标准 GB/T 17626.2: IEC 61000-4-2 The implementation standards are GB/T 17626.2 and IEC 61000-4-2 等级: IV级 (接触放电 8kV, 空气放电 15kV) Grade: IV (contact discharge 8kV, air discharge 15kV)
浪涌(冲击) 抗扰度试验 Surge (impact) immunity test	执行标准 GB/T 17626.5: IEC 61000-4-5 Comply with standards GB/T 17626.5 and IEC 61000-4-5 等级: IV级 (电源、电压端口差模 4kV, 电源、电压端口对其他端口共模 4kV; RS485 端口差模 2kV; DI 端口差模 1kV) Level: Level IV (differential mode of power and voltage ports: 4kV; common mode of power and voltage ports to other ports: 4kV; differential mode of RS485 port: 2kV; differential mode of DI port: 1kV)
射频电磁场辐射抗扰度试验 Radio frequency electromagnetic field	执行标准 GB/T 17626.3: IEC 61000-4-3 The implementation standards are GB/T 17626.3 and IEC 61000-4-3

radiation immunity test	等级: III级 (10V/m) Level: Level III (10V/m)
电压暂降和短时中断抗扰度 Immunity to voltage dips and short interruptions	执行标准 GB/T 17626.11 和 GB/T 17626.29 Implement the standards GB/T 17626.11 and GB/T 17626.29
射频场感应的传导骚扰抗扰度 Immunity to conducted disturbances induced by radio-frequency fields	执行标准 GB/T 17626.6; Implement the standard GB/T 17626.6; 等级: III级 (150kHz~80MHz 10V) Level: Level III (150kHz~80MHz 10V)
工频磁场抗扰度 Immunity to power frequency magnetic field	执行标准 GB/T 17626.8 The implementation standard is GB/T 17626.8 等级: IV级 Level: Level IV
脉冲磁场抗扰度 Pulse magnetic field immunity	执行标准 GB/T 17626.9 Implement the standard GB/T 17626.9 等级: V级 (1000 A/m) Grade: V Grade (1000 A/m)
阻尼振荡磁场抗扰度 Immunity to damped oscillatory magnetic field	执行标准 GB/T 17626.10 Implement the standard GB/T 17626.10 等级: V级 (100 A/m) Grade: V (100 A/m)
阻尼振荡波抗扰度 Damped oscillation wave immunity	执行标准 GB/T 17626.18 The implementation standard is GB/T 17626.18 等级: IV级 Level: Level IV
振荡波抗扰度 Oscillation wave immunity	执行标准 GB/T 17626.12 Implement the standard GB/T 17626.12 等级: IV级 Level: Level IV

第三章 功能介绍 Chapter 3: Function Introduction

3.1 测量功能 Measurement function

3.1.1 基本测量功能 Basic measurement function

本装置的实时数据测量功能包括全波数据测量和基波数据测量，测量数据可通过显示和通信读取，具体测量参数如下：

The real-time data measurement function of this device includes full-wave data measurement and fundamental wave data measurement.

The measured data can be read through display and communication. The specific measurement parameters are as follows:

1) 全波数据 Full-wave data

表 3-1 全波测量数据及分辨率

Table 3-1 Full-wave measurement data and resolution

名称 Name	A 相 Phase	B 相 Phase	C 相 Phase	均值 Mean value	总和 Sum	单位 Unit
相电压 Phase voltage	0.001	0.001	0.001	0.001	---	V
线电压 Line voltage	0.001	0.001	0.001	0.001	---	V
电流 Current	0.001	0.001	0.001	0.001	---	A
有功功率 Active power	0.1	0.1	0.1	--	0.1	W
无功功率 Reactive power	0.1	0.1	0.1	--	0.1	var
视在功率 Apparent power	0.1	0.1	0.1	--	0.1	VA
功率因数 Power factor	0.001	0.001	0.001	--	0.001	--
频率 Frequency	0.001					Hz
零线电流 Neutral current	0.001					A

注：此处的均值指 ABC 三相平均。

Note: The average value here refers to the average of the three phases of ABC.

2) 基波数据 Fundamental wave data

表 3-2 基波测量数据及分辨率

Table 3-2 Fundamental Wave Measurement Data and Resolution

名称 Name	A 相 Phase	B 相 Phase	C 相 Phase	均值 Mean value	总和 Sum	单位 Unit
相电压 Phase voltage	0.001	0.001	0.001	0.001	---	V
线电压 Line voltage	0.001	0.001	0.001	0.001	---	V
电流 Current	0.001	0.001	0.001	0.001	---	A
有功功率 Active power	0.1	0.1	0.1	--	0.1	W
无功功率 Reactive power	0.1	0.1	0.1	--	0.1	var

视在功率 Apparent power	0.1	0.1	0.1	--	0.1	VA
功率因数 Power factor	0.001	0.001	0.001	--	0.001	--
电压相角 Voltage phase angle	0.1	0.1	0.1	--	--	°
电流相角 Current phase angle	0.1	0.1	0.1	--	--	°

注：此处的均值指 ABC 三相平均。

Note: The average value here refers to the average of the three phases ABC.

3.1.2 频率测量 Frequency measurement

装置的频率测量精度为±0.01Hz，在范围为 42.5Hz 到 57.5Hz 内满足精度要求，可实现电力系统频率的在线监视，同时可设置超限报警和记录。测量时，若接线模式为三相四线，则使用 A 相电压作为参考；若接线方式为三相三线，则使用 AB 线电压作为参考。

The frequency measurement accuracy of the device is ±0.01Hz, meeting the accuracy requirements within the range of 42.5Hz to 57.5Hz. It can achieve online monitoring of power system frequency and can also set up off-limit alarms and records. During measurement, if the wiring mode is three-phase four-wire, the A-phase voltage is used as a reference; if the wiring mode is three-phase three-wire, the AB-line voltage is used as a reference.

3.1.3 功率因数定义方法 Definition method of power factor

功率因数的符号,采用 IEC 功率因数符号的定义，如图 3-1 所示：

The symbol for power factor adopts the definition of the IEC power factor symbol, as shown in Figure 3-1:

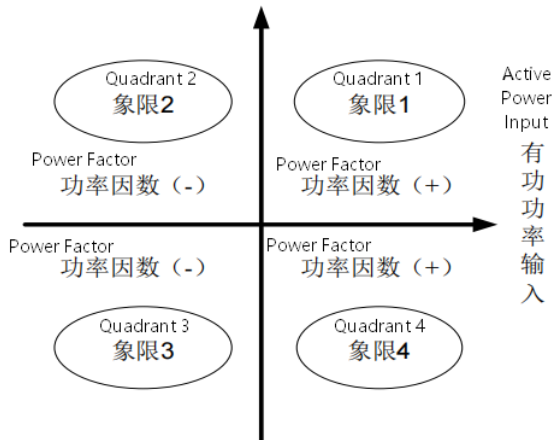

无功功率输入	Reactive power input	象限	Quadrant
有功功率输入	Active power input	功率因数	Power factor
IEC 功率因数符号定义方法		IEC power factor symbol definition method	

图 3-1 功率因数定义方法

Figure 3-1 Definition method of power factor

3.1.4 总视在功率的计算方法 Calculation method of total apparent power

装置提供两种总视在功率计算方法：标量法和矢量法。采用何种方法可以通过通信设定，两种计算方法公式如下：

The device provides two methods for calculating total apparent power: scalar method and vector method. The method to be used can be set through communication, and the formulas for the two calculation methods are as follows:

矢量法 Vector method:

$$kVA_{total} = \sqrt{kW_{total}^2 + k\text{var}_{total}^2}$$

标量法 Scalar method:

$$kVA_{total} = kVA_a + kVA_b + kVA_c$$

注意 Note:

1) 星形接线时，用户可根据需要设置矢量法或标量法计算总视在功率；角形接线时，无分相功率，应设置采用矢量法计算总视在功率。

In star connection, users can set the vector method or scalar method to calculate the total apparent power according to their needs; in delta connection, there is no split-phase power, and the vector method should be set to calculate the total apparent power.

2) 选择不同的总视在功率计算方法，会导致不同的总功率因数计算结果和视在电能累计结果。

Choosing different methods for calculating total apparent power will lead to varying results in the calculation of total power factor and the accumulation of apparent energy.

3) 以上公式中，表示总视在功率，表示总有功功率，表示总无功功率，kVAa/kVAb/kVAc 分别表示 A/B/C 相的视在功率。

In the above formula, kVA_{total} represents the total apparent power, kW_{total} represents the total active power, $k\text{var}_{total}$ represents the total reactive power, and kVAa/kVAb/kVAc represent the apparent power of A/B/C phases respectively.

3.2 电能计量 Electric energy metering

3.2.1 基本电能计量 Basic electric energy metering

装置提供丰富的电能计量数据便于用户分析系统的能耗。装置提供的电能数据如下。

The device provides rich electric energy metering data to facilitate users' analysis of system energy consumption. The electric energy data provided by the device is as follows.

表 3-3 电能计量数据

Table 3-3 Electric Energy Metering Data

	正向 Positive	反向 Reverse	总和 Sum	四象限 Four quadrants	组合无功 1 Combined reactive power 1	组合无功 2 Combined reactive power 2
全波有功电能 Full-wave active electric energy	√	√	√	--	--	--
全波无功电能 Full-wave reactive energy	--	--	--	√	√	√
全波视在电能 Full-wave apparent power	√	√	--	--	--	--
基波有功电能 Fundamental active	√	√	√	--	--	--

electric energy						
基波无功电能 Fundamental reactive energy	--	--	--	√	√	√
基波视在电能 Fundamental wave apparent power	√	√	--	--	--	--
总谐波有功电能 Total harmonic active energy	√	√	√	--	--	--
总谐波无功电能 Total harmonic reactive energy	--	--	--	√	√	√
总谐波视在电能 Total harmonic apparent energy	√	√	--	--	--	--
2~63 次谐波有功电能 Active electric energy of 2nd to 63rd harmonics	√	√	--	--	--	--
2~63 次谐波无功电能 Reactive electric energy of 2nd to 63rd harmonics	√	√	--	--	--	--
注：全波、基波、总谐波电能具有分相电能，三角形接线无谐波电能 Note: Full-wave, fundamental wave, and total harmonic electric energy have phase-separated electric energy, while delta connection has no harmonic electric energy						

3.2.2 电能翻转和清零 Electric energy reversal and resetting

装置记录电能的最大值为 2147483.647kWh(二次侧)，当电能大于最大值时，电能重新从 0 开始累计。可通过按键和通信进行电能的清零。

The maximum recorded electric energy value for the device is 2147483.647 kWh (secondary side). When the electric energy exceeds the maximum value, it will start accumulating again from 0. The electric energy can be reset to zero through buttons or communication.

3.2.3 电能脉冲 Electric energy pulse

支持有功电能脉冲输出及无功电能脉冲输出。

Supports both active and reactive electric energy pulse output.

3.3 需量 Demand

电力系统中常根据用户的电能消耗（以有功电能的形式）和峰值用电水平（以有功功率形式）来收取费用。需量的定义为一定时间间隔（通常 15 分钟）内的均值。

In the electric power system, fees are often charged based on the electric energy consumption (in the form of active electric energy) and peak electricity usage level (in the form of active power) of users. Demand is defined as the average value within a certain time interval (usually 15 minutes).

3.3.1 实时需量 Real-time demand

装置除了提供常见的有功需量外，还提供无功、视在、三相电流的实时需量。

In addition to providing common active demand, the device also offers real-time demand for reactive power, apparent power, and three-phase current.

实时需量计算模式为：滑动需量。

The real-time demand calculation mode is: sliding demand.

表 3-4 需量数据

Table 3-4 Demand Data

项目 Item	单位 Unit
A 相电流需量 A phase current demand	A
B 相电流需量 B-phase current demand	A
C 相电流需量 C-phase current demand	A
正向总有功功率需量 Positive total active power demand	W
反向总有功功率需量 Reverse total active power demand	W
正向总无功功率需量 Positive total reactive power demand	var
反向总无功功率需量 Reverse total reactive power demand	var
总视在功率需量 Total apparent power demand	VA

3.3.2 需量算法 Demand calculation method

需量采用滑差周期需量算法，将每秒的计算值相加，在需量计算周期结束时求取平均值，输出计算结果。电流，功率都采用此计算方法。需量计算采用整分整秒进行计算。需量周期可设置为 5,10,15,30,60;单位为分钟。

The demand is calculated using a slip cycle demand algorithm, where the calculated values per second are added up and an average is obtained at the end of the demand calculation cycle, and the calculation result is output. Both current and power adopt this calculation method. Demand calculation is performed in whole minutes and seconds. The demand cycle can be set to 5, 10, 15, 30, 60; the unit is minutes.

滑差需量：从任意时刻起，按小于需量周期的时间递推测量需量的方法，所测得的需量叫滑差需量。依次递推测量需量的间隔时间叫滑差时间。滑差时间一般采用 1 分钟，需量周期一般是采用 15 分钟。

Sliding demand: The method of measuring demand by advancing forward in time by a period shorter than the demand cycle from any given moment, and the measured demand is called sliding demand. The interval between successive measurements of demand is called sliding time. The sliding time is generally set at 1 minute, and the demand cycle is generally set at 15 minutes.

滑差需量参数如下：

The slip demand parameters are as follows:

滑差时间：可在 1, 2, 3, 5min 中选择设置。

Slip time: Can be set to 1, 2, 3, or 5 minutes.

需量周期：可在 5, 10, 15, 30, 60min 中选择设置，同时需量周期应为滑差子周期(滑差时间)的 5 的整数倍。

Demand period: It can be set to 5, 10, 15, 30, or 60 minutes, and the demand period should be an integer multiple of 5 times the slip sub-period (slip time).

以上参数可通过上位机进设置。

The above parameters can be set through the host computer.

3.3.3 最大需量 Maximum demand

装置提供本次、上 1~12 次最大需量记录，记录最大需量值及其产生时间，装置提供以下参数的最大需量：

The device provides records of the current and the previous 1 to 12 maximum demand values, including the recorded maximum demand values and their occurrence times. The device also provides the maximum demand values for the following parameters:

表 3-5 最大需量数据

Table 3-5 Maximum demand data

项目 Item	单位 Unit	发生时刻 Occurrence time
A 相电流需量 A phase current demand	A	年月日时分秒 Year Month Day Hour Minute Second
B 相电流需量 B-phase current demand	A	年月日时分秒 Year Month Day Hour Minute Second
C 相电流需量 C-phase current demand	A	年月日时分秒 Year Month Day Hour Minute Second
正向总有功功率需量 Positive total active power demand	W	年月日时分秒 Year Month Day Hour Minute Second
反向总有功功率需量 Reverse total active power demand	W	年月日时分秒 Year Month Day Hour Minute Second
正向总无功功率需量 Positive total reactive power demand	var	年月日时分秒 Year Month Day Hour Minute Second
反向总无功功率需量 Reverse total reactive power demand	var	年月日时分秒 Year Month Day Hour Minute Second
总视在功率需量 Total apparent power demand	VA	年月日时分秒 Year Month Day Hour Minute Second

通过转存时间可设置本次最大需量转存为上次最大需量的方式，转存后本次最大需量记录清零，重新统计记录最大需量值。转存时间可设置为：月末或固定每月 xx 日 xx 时自动转存。

The method of transferring the current maximum demand to the previous maximum demand can be set through the transfer time. After the transfer, the record of the current maximum demand is reset to zero, and the maximum demand value is re-calculated and recorded. The transfer time can be set to: automatic transfer at the end of the month or at a fixed time on the xx day of each month.

3.4 分时计量 (TOU) 功能 Time-of-Use (TOU) function

装置共有两套费率方案，每套费率方案包含时区设置、日时段表设置和特殊日设置。在电力系统中，工作日、周末日和节假日的电价可能是不同的，负荷峰值期间和非峰值期间的电价也不同。本功能是为适应峰谷分时电价的需要而提供的一种电能计量方式，可根据预先设定的计费时段及费率，分别计算累加各分时费率的电量，来实现分时计量的功能。在 TOU 功能中，时间设定以年为周期，每年可设置普通日和特殊日，特殊日最多可设置 14 个。一年最多可设置 14 个时区，一周可设置为工作日/周末日 2 种类型，并分别设置对应的日时段表号；日时段表最多可设置 8 个，每个日时段表以 15min 为步长将 1 天 24 小时划分为最多 14 个时段，每个时段对应唯一费率，最多可设置 8 种。对于节假日，如需单独设置时，可通过设置特殊日寄存器指定特殊日日期及对应的日时段表来实现。

The device features two rate schemes, each encompassing time zone settings, daily time period table settings, and special day settings. In the electric power system, electricity prices may vary between weekdays, weekends, and holidays, as well as during peak and off-peak load periods. This function offers an electric energy metering approach tailored to the needs of time-of-use (TOU) pricing, enabling the calculation and accumulation of electricity consumption at various time-of-use rates based on preset billing periods and rates, thus achieving time-of-use metering. Within the TOU function, time settings are organized on an annual basis, allowing for the designation of ordinary days and special days, with a maximum of 14 special days per year. Up to 14 time zones can be set annually, and the week can be configured as either weekdays or weekend days, with corresponding daily time period table numbers set for each. Each daily time period table can

accommodate up to 8 time periods, with each period spanning 15 minutes and dividing a 24-hour day into a maximum of 14 periods. Each period corresponds to a unique rate, with a maximum of 8 rates that can be set. For holidays, if separate settings are required, the special day register can be used to specify the date of the special day and the corresponding daily time period table.

两套方案可独立设置复费率方案，通过设置两套方案的切换日期来自动切换。

Two sets of schemes can independently set up multi-rate schemes, and automatically switch between them by setting the switching date for the two sets of schemes.

复费率功能可实现组合、正向、反向有功，四象限、组合无功，正反向视在电能的分时计量，并提供正反向有功、无功、总视在功率各费率时段的需量最值。各费率时段最大电能翻转值为 2147483.647KWh.

The multifunctional tariff feature enables time-of-use metering for combined, forward, and reverse active energy, four-quadrant, combined reactive energy, and forward and reverse apparent energy. It also provides the maximum demand values for forward and reverse active, reactive, and total apparent power during each tariff period. The maximum energy reversal value during each tariff period is 2147483.647KWh

表 3-6 TOU 记录参数

Table 3-6 TOU Recording Parameters

电能 Electric energy	组合、正向、反向有功电能 Combined, forward, and reverse active energy
	组合无功 1、组合无功 2、1 象限、2 象限、3 象限、4 象限无功电能 Combined reactive power 1, combined reactive power 2, 1 st quadrant, 2 nd quadrant, 3 rd quadrant, 4 th quadrant reactive energy
	正向、反向视在电能 Forward and reverse apparent power
最大需量 Maximum Demand	正向有功、无功需量 Positive active and reactive power demand
	反向有功、无功需量 Reverse active and reactive power demand
	总视在需量 Total apparent demand

参数范围如下 The parameter range is as follows:

计费时区: 1~14 个时区, 时区 1 起始时间为 1 月 1 日, 不可更改。时区方案设置规则为: 后一个时区日期应比前一个时区晚, 同时时区方案的时区数小于设置的时区数时, 按照最后一个时区补齐。

Billing time zones: 1 to 14 time zones. The starting time for time zone 1 is January 1st and cannot be changed. The setting rule for the time zone scheme is: the date of the subsequent time zone should be later than that of the previous one. When the number of time zones in the scheme is less than the number of time zones set, the last time zone will be used to make up the difference.

计费日类型: 工作日/周末日两种, 可分开设置日时段表。

Billing day type: There are two types: weekdays and weekends, and the daily time period tables can be set separately.

日时段表: 最多 8 个时段表, 每个表可最多设置 14 个时段, 每个时段最小时间单位为 15 分钟, 且应大于装置内设定的需量周期。对于每一个日时段表, 它们的时段设置规则为: 后一个时段时间应比前一个时段晚。

Daily schedule: Up to 8 schedules can be set, with each schedule containing up to 14 time slots. The minimum time unit for each time slot is 15 minutes, and it should be longer than the demand cycle set within the device. For each daily schedule, the rule for setting time slots is that the next time slot should start later than the previous one.

特殊日: 0~14 个, 每个特殊日可单独指定日时段表。

Special days: 0 to 14, with a separate schedule designated for each special day.

费率: 8 个费率。

Tariff: 8 tariffs.

时区表切换时间: 两套年时区表的自动切换时间:

Time zone table switching time: The automatic switching time between the two sets of annual time zone tables;

时段表切换时间：两套日时段表的自动切换时间；

Time for schedule switching: The automatic switching time between the two sets of daily schedules;

本功能只在通讯提供设置、查看

This function is only available for setting and viewing communication settings

3.5 稳态电能质量监测功能 Steady-state power quality monitoring function

3.5.1 谐波、间谐波监测 Harmonic and inter-harmonic monitoring

(1) 基本测量 Basic measurement

对周期性交流量进行傅里叶级数分解，得到的频率与工频相同的分量称为基波分量，得到频率为基波分量频率大于1的整数倍的分量称为谐波分量，得到频率不等于基波频率整数倍的分量称为间谐波，得到频率低于基波频率的分量称为次谐波。公用电网理想运行时，所提供的电压频率应是单一而固定的，电压幅值应等于规定值。而谐波电压与谐波电流的出现，对公用电网来说是一种污染，会对用电设备造成一定程度的危害。因此，需要对谐波进行在线监测，以保证供电质量。

When the periodic AC quantity is decomposed using Fourier series, the component with the same frequency as the power frequency is called the fundamental component. The component with a frequency that is an integer multiple greater than the fundamental component frequency is called the harmonic component. The component with a frequency that is not an integer multiple of the fundamental frequency is called the interharmonic, and the component with a frequency lower than the fundamental frequency is called the subharmonic. When the utility grid operates ideally, the provided voltage frequency should be single and fixed, and the voltage amplitude should be equal to the specified value. However, the presence of harmonic voltage and harmonic current is a form of pollution to the utility grid and can cause certain harm to electrical equipment. Therefore, online monitoring of harmonics is necessary to ensure the quality of power supply.

本装置每周波采样1024点，在额定频率为50Hz时，以10个周波为时间窗口做一次FFT（快速傅里叶变换），频率分辨率为5Hz，可测量得到各次谐波分量（有效值与相角）和间谐波分量（有效值），从而计算出各次谐波含有率、总谐波畸变率、奇次谐波畸变率与偶次谐波畸变率。

This device samples 1024 points per cycle per week. At a rated frequency of 50Hz, it performs an FFT (Fast Fourier Transform) with a time window of 10 cycles, achieving a frequency resolution of 5Hz. It can measure various harmonic components (effective value and phase angle) and interharmonic components (effective value), thereby calculating the harmonic content rate, total harmonic distortion rate, odd harmonic distortion rate, and even harmonic distortion rate.

表 3-7 谐波分析数据

Table 3-7 Harmonic Analysis Data

	UA/A 相 UA/A phase	UB/B 相 UB/B phase	UC/C 相 UC/C phase	总和 Sum	IA	IB	IC	14
2~63 次谐波有效值 Effective values of 2 nd to 63 rd harmonics	√	√	√	--	√	√	√	√
2~63 次谐波相角 Phase angle of 2 nd to 63 rd harmonics	√	√	√	--	√	√	√	√
2~63 次谐波含有率 2 nd to 63 rd harmonic content	√	√	√	--	√	√	√	√
总谐波畸变率 Total harmonic distortion	√	√	√	--	√	√	√	√

奇次谐波总畸变率 Total distortion rate of odd harmonics	√	√	√	--	√	√	√	√
偶次谐波总畸变率 Total distortion rate of even-order harmonics	√	√	√	--	√	√	√	√
总谐波有效值 Total harmonic distortion (THD)	√	√	√	--	√	√	√	√
奇次谐波有效值 Effective value of odd harmonics	√	√	√	--	√	√	√	√
偶次谐波有效值 Effective value of even-order harmonic	√	√	√	--	√	√	√	√
电流 K 因子 Current K factor	--	--	--	--	√	√	√	--
峰值因子 Peak factor	√	√	√	--	√	√	√	--
1~63 次间谐波有效值 Effective value of 1~63 rd order inter-harmonics	√	√	√	--	√	√	√	--
1~63 次间谐波含有率 Inter-harmonic content rate of 1~63 times	√	√	√	--	√	√	√	--
次谐波有效值 Effective value of sub-harmonic	√	√	√	--	√	√	√	--
次谐波畸变率 Sub-harmonic distortion rate	√	√	√	--	√	√	√	--
间谐波总畸变率 Total distortion rate of inter-harmonics	√	√	√	--	√	√	√	--
奇次间谐波畸变率 Odd-order inter-harmonic distortion rate	√	√	√	--	√	√	√	--
偶次间谐波畸变率 Even-order inter-harmonic distortion rate	√	√	√	--	√	√	√	--
谐波总有功功率 Harmonic total active power	√	√	√	√	--	--	--	--
谐波总无功功率 Total harmonic reactive power	√	√	√	√	--	--	--	--
谐波总视在功率 Total harmonic apparent power	√	√	√	√	--	--	--	--

Total harmonic apparent power								
2~63 次谐波有功功率 Active power of 2 nd to 63 rd harmonics	√	√	√	--	--	--	--	--
2~63 次谐波无功功率 Reactive power of 2 nd to 63 rd harmonics	√	√	√	--	--	--	--	--
2~63 次谐波视在功率 2 nd to 63 rd harmonic apparent power	√	√	√	--	--	--	--	--
2~63 次谐波功率因数 2 nd to 63 rd harmonic power factor	√	√	√	√	--	--	--	--

表 3-7 中谐波有功功率/无功功率为一次值，三角形接线无效。

In Table 3-7, the harmonic active power/reactive power is presented as a primary value, and the triangular connection is invalid.

(2) 计算方法 Calculation method

经过 FFT 后可得到各次谐波的有效值和相角，从而计算出功率因数、有功功率、无功功率等参数。而含有率和畸变率等参数的计算公式如下：

After FFT, the effective value and phase angle of each harmonic can be obtained, and then parameters such as power factor, active power, and reactive power can be calculated. The calculation formulas for parameters such as content rate and distortion rate are as follows:

谐波有效值计算

1) Harmonic effective value calculation

➤ 谐波群和间谐波群 Harmonic group and inter harmonic group

经过 DFT 或 FFT 后输出的频谱分量如下图所示，每 5Hz 一条频谱线，根据下述公式进行分群，分群为两个临近谐波之间的各中间分量的平方和（仅使用 2 次谐波以上的中间分量），并计算得到 h 次谐波的方均根值。由第 h 次谐波群计算出第 h 次谐波有效值，由介于第 h 次和第 h+1 次谐波之间的间谐波群的方均根值计算出第 h 次间谐波的有效值，介于 0 次和 1 次谐波之间的间谐波群称为次谐波（可看作 0 次间谐波）。

The spectral components output after DFT or FFT are shown in the figure below, with one spectral line per 5Hz. They are grouped according to the following formula, which groups the intermediate components between two adjacent harmonics (only using intermediate components above the second harmonic) and calculates the root mean square value of the h-th harmonic. The effective value of the h-th harmonic is calculated from the h-th harmonic group, and the effective value of the h-th inter harmonic is calculated from the root mean square value of the inter harmonic group between the h-th and (h+1)-th harmonics. The inter harmonic group between the 0-th and 1-st harmonics is called the sub-harmonic (which can be regarded as the 0-th inter harmonic).

$$\text{谐波 Harmonic: } Y_{g,h} = \sqrt{\frac{1}{2} Y_{C,(N \times h) - N/2}^2 + \sum_{k=(-N/2)+1}^{(N/2)-1} Y_{C,(N \times h) + k}^2 + \frac{1}{2} Y_{C,(N \times h) + N/2}^2}$$

$$\text{间谐波 Inter harmonic: } Y_{ig,h} = \sqrt{\sum_{k=1}^{N-1} Y_{C,(N \times h) + k}^2}$$

式中 Where:

$Y_{C,(N \times h) + k}$ 为与 DFT 或 FFT 输出的频谱分量相对应的方均根值；

$Y_{C,(N \times h) + k}$ It refers to the root mean square value corresponding to the spectral components output by DFT or FFT;

$(N \times h) + k$ 为频谱分量的次数:

$(N \times h) + k$ refers to the order of spectral components;

$Y_{g,h}$ 为谐波群的方均根值:

$Y_{g,h}$ It is the root-mean-square value of the harmonic group;

$Y_{ig,h}$ 为间谐波群的方均根值。

$Y_{ig,h}$ It is the root-mean-square value of the inter-harmonic group.

示例 Example:

对于 50Hz 的系统, 若傅里叶变换后的频率分辨率为 5Hz, 则 $N = \frac{50}{5} = 10$ 。以 2 次谐波为例, 其谐波群从第 $(N \times h) - \frac{N}{2} = (10 \times 2) - 5 = 15$ 个频谱分量开始, 即 $15 \times 5 = 75\text{Hz}$ 开始, 到第 $(N \times h) + \frac{N}{2} = (10 \times 2) + 5 = 25$ 个频谱分量结束, 即 $25 \times 5 = 125\text{Hz}$ 结束, 共 11 条频谱线。对于 1 次间谐波, 则从第 $(N \times h) + 1 = (10 \times 1) + 1 = 11$ 个频谱分量开始, 即 $11 \times 5 = 55\text{Hz}$ 开始, 到第 $(N \times h) + (N - 1) = (10 \times 1) + (10 - 1) = 19$ 个频谱分量结束, 即 $19 \times 5 = 95\text{Hz}$ 结束, 共 9 条频谱线。

For a 50Hz system, if the frequency resolution after Fourier transform is 5Hz, then, $tN = \frac{50}{5} = 10$ taking the second harmonic as an example, its harmonic group starts from the first spectral component, i.e., $15 \times 5 = 75\text{Hz}$ starts, and ends at the $(N \times h) + \frac{N}{2} = (10 \times 2) + 5 = 25$ th spectral component, i.e., $25 \times 5 = 125\text{Hz}$ ends, with a total of 11 spectral lines. For the first-order inter harmonic, it starts from the $(N \times h) + 1 = (10 \times 1) + 1 = 11$ th spectral component, i.e., $11 \times 5 = 55\text{Hz}$ starts, and ends at the $(N \times h) + (N - 1) = (10 \times 1) + (10 - 1) = 19$ th spectral component, i.e., $19 \times 5 = 95\text{Hz}$ ends, with a total of 9 spectral lines.

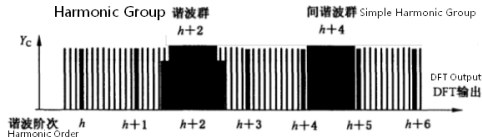

谐波群	Harmonic group	谐波阶次	Harmonic order
间谐波群	inter-harmonic group	DFT 输出	DFT output

图 3-2 谐波群和间谐波群示意图

Figure 3-2 Schematic diagram of harmonic group and inter-harmonic group

➤ 谐波子群和间谐波中心子群 Harmonic subgroup and inter harmonic central subgroup

傅里叶变换分析假设信号是稳态的, 然而供电系统的电压幅值可能会出现波动, 将谐波分量的能量扩散到与之临近频率的频谱上。为提高评估准确度, 可按照如下公式进行分群。

The Fourier transform analysis assumes that the signal is steady-state. However, the voltage amplitude of the power supply system may fluctuate, spreading the energy of harmonic components to the frequency spectrum adjacent to it. To improve evaluation accuracy, clustering can be performed according to the following formula.

$$\text{谐波 Harmonic: } Y_{sg,h} = \sqrt{\sum_{k=-1}^1 Y_{C,(N \times h) + k}^2}$$

$$\text{间谐波 Inter harmonic: } Y_{isg,h} = \sqrt{\sum_{k=2}^{N-2} Y_{C,(N \times h) + k}^2}$$

式中 Where:

$Y_{C,(N \times h) + k}$ 为与 DFT 或 FFT 输出的频谱分量相对应的方均根值;

$Y_{C,(N \times h) + k}$ The root mean square value corresponding to the spectral components output by DFT or FFT;

$(N \times h) + k$ 为频谱分量的次数;

$(N \times h) + k$ It is the order of the spectral component;

$Y_{sg,h}$ 为谐波子群的方均根值;

$Y_{sg,h}$ It is the root-mean-square value of the harmonic subgroup;

$Y_{isg,h}$ 为间谐波中心子群的方均根值。

$Y_{isg,h}$ It is the root-mean-square value of the inter-harmonic central sub-group.

示例 Example

对于 50Hz 的系统,若傅里叶变换后的频率分辨率为 5Hz,则 $N = \frac{50}{5} = 10$ 。以 2 次谐波为例,其谐波子群从第 $(N \times h) - 1 = (10 \times 2) - 1 = 19$ 个频谱分量开始,即 $19 \times 5 = 95\text{Hz}$ 开始,到第 $(N \times h) + 1 = (10 \times 2) + 1 = 21$ 个频谱分量结束,即 $25 \times 5 = 105\text{Hz}$ 结束,共 3 条频谱线。对于 1 次间谐波,则间谐波中心子群从第 $(N \times h) + 2 = (10 \times 1) + 2 = 12$ 个频谱分量开始,即 $12 \times 5 = 60\text{Hz}$ 开始,到第 $(N \times h) + (N - 2) = (10 \times 1) + (10 - 2) = 18$ 个频谱分量结束,即 $18 \times 5 = 90\text{Hz}$ 结束,共 7 条频谱线。

For a 50Hz system, if the frequency resolution after Fourier transform is 5Hz, then, $tN = \frac{50}{5} = 10$ taking the second harmonic as an example, its harmonic subgroup starts from the $(N \times h) - 1 = (10 \times 2) - 1 = 19$ th spectral component, i.e., $19 \times 5 = 95\text{Hz}$ starts, and ends at the $(N \times h) + 1 = (10 \times 2) + 1 = 21$ th spectral component, i.e., $25 \times 5 = 105\text{Hz}$ ends, with a total of 3 spectral lines. For the first-order inter-harmonic, the inter-harmonic central subgroup starts from the $(N \times h) + 2 = (10 \times 1) + 2 = 12$ spectral component, i.e., $12 \times 5 = 60\text{Hz}$ starts, and ends at the $(N \times h) + (N - 2) = (10 \times 1) + (10 - 2) = 18$ th spectral component, i.e., $18 \times 5 = 90\text{Hz}$ ends, with a total of 7 spectral lines.

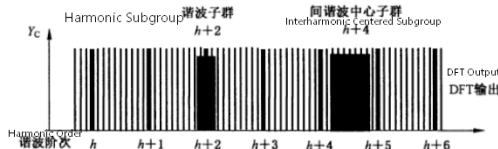

谐波子群	Harmonic sun-group	谐波阶次	Harmonic order
间谐波中心子群	Inter-harmonic central sub-group	DFT 输出	DFT output

图 3-3 谐波子群和间谐波中心子群示例

Figure 3-3 Example of harmonic sub-group and inter-harmonic central sub-group

2) 谐波功率计算 Harmonic power calculation

经过 FFT 后可得到各次谐波的相角,从而计算出功率因数、有功功率、无功功率等参数。

After FFT, the phase angle of each harmonic can be obtained, and then parameters such as power factor, active power, and reactive power can be calculated.

h 次谐波相对相角 $\varphi_h = h$ 次谐波电压相角 - h 次谐波电流相角

$$h \text{ 次谐波功率因数} = \cos(\varphi_h)$$

$$h \text{ 次谐波有功功率} = U_h I_h \cos \varphi_h$$

$$h \text{ 次谐波无功功率} = U_h I_h \sin \varphi_h$$

$$h \text{ 次谐波视在功率} = U_h I_h$$

$$\text{总谐波有功功率} = \sum_{h=2}^{63} U_h I_h \cos \varphi_h$$

$$\text{总谐波无功功率} = \sum_{h=2}^{63} U_h I_h \sin \varphi_h$$

$$\text{总谐波视在功率} = \sqrt{\text{总谐波有功功率}^2 + \text{总谐波无功功率}^2}$$

$$\text{总功率因数} = \frac{\text{总谐波有功功率}}{\text{总谐波视在功率}}$$

h-th harmonic relative phase angle φ_h = the phase angle of the h-th harmonic voltage minus the phase angle - the h-th harmonic current

h-th harmonic power factor = $\cos(\varphi_h)$

h-th harmonic active power = $U_h I_h \cos \varphi_h$

h-th harmonic reactive power = $U_h I_h \sin \varphi_h$

h-th harmonic apparent power = $U_h I_h$

Total harmonic active power = $\sum_{h=2}^{63} U_h I_h \cos \varphi_h$

Total harmonic reactive power = $\sum_{h=2}^{63} U_h I_h \sin \varphi_h$

Total harmonic apparent power = $\sqrt{\text{Total harmonic active power}^2 + \text{Total harmonic reactive power}^2}$

$$\text{Total power factor} = \frac{\text{Total harmonic active power}}{\text{Total harmonic apparent power}}$$

3) 谐波含有率与畸变率 Harmonic content and distortion rate:

$$h \text{ 次谐波含有率} = \frac{h \text{ 次谐波有效值}}{\text{基波有效值}} \times 100\%$$

$$\text{总谐波畸变率} = \left(\frac{\sqrt{\sum_{h=2}^N (\text{h 次谐波有效值})^2}}{\text{基波有效值}} \right) \times 100\%$$

$$\text{次谐波畸变率} = \frac{\text{次谐波有效值}}{\text{基波有效值}} \times 100\%$$

h 次谐波含有率	h-th harmonic content	总谐波畸变率	Total harmonic distortion
h 次谐波有效值	Effective value of h-th harmonic	次谐波畸变率	Sub-harmonic distortion rate
基波有效值	Fundamental wave effective value		

注: 1. 间谐波计算公式同谐波。

Note: 1. The calculation formula for inter-harmonics is the same as that for harmonics.

2. 奇次谐波畸变率仅计算 1、3、5、7……次谐波，偶次谐波畸变率仅计算 2、4、6、8……次谐波。

The odd-order harmonic distortion rate only calculates the 1st, 3rd, 5th, 7th... order harmonics, while the even-order harmonic distortion rate only calculates the 2nd, 4th, 6th, 8th... order harmonics.

4) 峰值因子 Peak factor

峰值因子为测量量峰值与有效值之比，理想正弦波的峰值因子=1.414。本装置提供 ABC 三相电压和 ABC 三相电流的峰值因子，取 10 周期时间窗内的最高样本值与方均根值作为计算。

The crest factor is the ratio of the measured peak value to the effective value, and the crest factor of an ideal sine wave is 1.414. This device provides the crest factors of ABC three-phase voltage and ABC three-phase current, calculated by taking the highest sample value and the root-mean-square value within a 10-cycle time window.

$$\text{峰值因子 CF} = \frac{|\text{测量量峰值}|}{\text{测量量有效值}}$$

峰值因子	Peak factor CF	测量量有效值	Effective value of measurement quantity
测量量峰值	Peak measurement quantity		

5) K 因子 K factor

当系统中存在谐波时，谐波电流注入变压器，加大了变压器的铁耗，而且随着谐波频率的增高，铁耗更大。所以高次谐波比低次谐波更能引起变压器的发热，引起的损耗更大。同时，谐波电流还会引起变压器外壳、外层硅钢片和某些紧固件的发热。在电能质量的技术指标中，K 因子主要是反映非线性负荷引起的谐波的频率对变压器损耗的影响。K 因子的定义主要是在假定由谐波电流引起的变压器涡流损耗与谐波次数的平方成比例。计算公式为：

When harmonics exist in the system, harmonic currents are injected into the transformer, increasing its iron loss. Furthermore, as the harmonic frequency increases, the iron loss becomes greater. Therefore, higher-order harmonics cause more heating and greater loss in the transformer than lower-order harmonics. At the same time, harmonic currents can also cause heating of the transformer housing, outer silicon steel sheets, and certain fasteners. In the technical indicators of power quality, the K factor mainly reflects the impact of the frequency of harmonics caused by nonlinear loads on transformer loss. The definition of the K factor is mainly based on the assumption that the eddy current loss of the transformer caused by harmonic currents is proportional to the square of the harmonic order. The calculation formula is:

$$k = \frac{\sum_{h=1}^{\infty} I_h^2 h^2}{\sum_{h=1}^{\infty} I_h^2} = \frac{\sum_{h=1}^{h_{\max}} I_h^2 h^2}{\sum_{h=1}^{h_{\max}} I_h^2}$$

其中，h 为谐波次数，为第 h 次谐波电流有效值，为所要考虑谐波电流最高次次数。

Where h represents the harmonic order, I_h represents the effective value of the hth harmonic current, h_{\max} and represents the highest order of the harmonic current to be considered.

(3) 越限事件 Out-of-limit event

➤ 有效值/含有率越限 (二选一，电压选含有率，电流选有效值) Effective value/content rate exceeding limit (choose one from voltage content rate or current effective value)

1) 以电压选含有率和电流选有效值为例，则包含如下参数：

1) Taking voltage selection for content rate and current selection for effective value as examples, the following parameters are included:

A 相 2~63 次谐波电压含有率；B 相 2~63 次谐波电压含有率；C 相 2~63 次谐波电压含有率；

Phase A 2nd to 63rd harmonic voltage content rate; Phase B 2nd to 63rd harmonic voltage content rate; Phase C 2nd to 63rd harmonic voltage content rate;

A 相 2~63 次谐波电流有效值；B 相 2~63 次谐波电流有效值；C 相 2~63 次谐波电流有效值；

Effective value of harmonic current from 2nd to 63rd order for Phase A; Effective value of harmonic current from 2nd to 63rd order for Phase B; Effective value of harmonic current from 2nd to 63rd order for Phase C;

A 相 1~63 次间谐波电压含有率；B 相 1~63 次间谐波电压含有率；C 相 1~63 次间谐波电压含有率；

Phase A 1st to 63rd order inter-harmonic voltage content; Phase B 1st to 63rd order inter-harmonic voltage content; Phase C 1st to 63rd order inter-harmonic voltage content;

A 相 1~63 次间谐波电流有效值；B 相 1~63 次间谐波电流有效值；C 相 1~63 次间谐波电流有效值。

Effective value of 1~63rd order inter-harmonic current in Phase A; Effective value of 1~63rd order inter-harmonic current in Phase B; Effective value of 1~63rd order inter-harmonic current in Phase C.

2) 判定方法 (以 A 相 2 次谐波电压为例)

2) Judgment method (taking the second harmonic voltage of phase A as an example)

开始条件：U_a 的 2 次谐波电压含有率大于“2 次谐波电压含有率动作限值”，且持续时间大于“2 次谐波电压含有率动作延时”。

Initial condition: The 2nd harmonic voltage content of Ua exceeds the "2nd harmonic voltage content action limit", and the duration exceeds the "2nd harmonic voltage content action delay".

结束条件: Ua 的 2 次谐波电压含有率恢复到小于“2 次谐波电压含有率返回限值”, 且持续时间大于“2 次谐波电压含有率返回延时”。

End condition: The second harmonic voltage content of Ua recovers to less than the "return limit value of second harmonic voltage content" and the duration exceeds the "return delay time of second harmonic voltage content".

3) 设置参数 (以 A 相 2 次谐波电压为例)

3) Set parameters (taking the 2nd harmonic voltage of phase A as an example)

2 次谐波电压含有率动作限值: 默认 2.00%, 范围 0~99.99%;

Operating limit for 2nd harmonic voltage content: default 2.00%, range 0~99.99%;

2 次谐波电压含有率动作延时: 默认 5s, 范围 1.00~99.99s;

Action delay for 2nd harmonic voltage content rate: default 5s, range 1.00~99.99s;

2 次谐波电压含有率返回限值: 默认 1.90%, 范围 0~99.99%;

Return limit of 2nd harmonic voltage content: default 1.90%, range 0~99.99%;

2 次谐波电压含有率返回延时: 默认 5s, 范围 1.00~99.99s;

Return delay of 2nd harmonic voltage content rate: default 5s, range 1.00~99.99s;

2 次谐波电压含有率触发动作: 无/DO1/DO2/DO3/DO4。

2nd harmonic voltage content rate triggers action: None/DO1/DO2/DO3/DO4.

4) 记录参数 (以 A 相 2 次谐波电压为例)

4) Record parameters (taking the 2nd harmonic voltage of phase A as an example)

越限的发生时刻、A 相 2 次谐波电压含有率动作值;

The occurrence time of the out-of-limit condition and the action value of the 2nd harmonic voltage content rate in phase A;

越限的结束时刻、A 相 2 次谐波电压含有率返回值、越限期间 A 相 2 次谐波电压含有率最大值、越限持续时间。

The end time of the out-of-limit condition, the return value of the A-phase 2nd harmonic voltage content rate, the maximum value of the A-phase 2nd harmonic voltage content rate during the out-of-limit period, and the duration of the out-of-limit condition.

5) 其余参数超限原理同上, 各次谐波均可独立设置对应的含有率定值或有效值定值。

5) The principle for exceeding limits of other parameters is the same as above, and each harmonic can be independently set with a corresponding rated value or effective value.

➤ 畸变率超限 Distortion rate exceeds the limit

1) 包含如下参数:

Includes the following parameters:

ABC 相电压总谐波畸变率; ABC 相电压总奇次谐波畸变率; ABC 相电压总偶次谐波畸变率;

Total harmonic distortion rate of ABC phase voltage; Total odd harmonic distortion rate of ABC phase voltage; Total even harmonic distortion rate of ABC phase voltage;

ABC 相电流总谐波畸变率; ABC 相电流总奇次谐波畸变率; ABC 相电流总偶次谐波畸变率;

Total harmonic distortion rate of ABC phase current; Total odd harmonic distortion rate of ABC phase current; Total even harmonic distortion rate of ABC phase current;

ABC 相电压总间谐波畸变率; ABC 相电压总奇次间谐波畸变率; ABC 相电压总偶次间谐波畸变率;

Total inter-harmonic distortion rate of ABC phase voltage; Total odd-order inter-harmonic distortion rate of ABC phase voltage; Total even-order inter-harmonic distortion rate of ABC phase voltage;

ABC 相电流总谐波畸变率；ABC 相电流总奇次间谐波畸变率；ABC 相电流总偶次间谐波畸变率。

Total inter-harmonic distortion rate of ABC phase currents; Total odd-order inter-harmonic distortion rate of ABC phase currents; Total even-order inter-harmonic distortion rate of ABC phase currents.

2) 判定方法（以 A 相电压总谐波畸变率为例）

Judgment method (taking the total harmonic distortion rate of A-phase voltage as an example)

开始条件：A 相电压总谐波畸变率大于“电压总谐波畸变率动作限值”，且持续时间大于“电压总谐波畸变率动作延时”。

Starting condition: The total harmonic distortion rate of phase A voltage is greater than the "action limit value of total harmonic distortion rate of voltage", and the duration is greater than the "action delay time of total harmonic distortion rate of voltage".

结束条件：A 相电压总谐波畸变率恢复到小于“电压总谐波畸变率返回限值”，且持续时间大于“电压总谐波畸变率返回延时”。

End condition: The total harmonic distortion rate of phase A voltage recovers to less than the "return limit value of total harmonic distortion rate of voltage", and the duration is greater than the "return delay time of total harmonic distortion rate of voltage".

3) 设置参数（以 A 相电压总谐波畸变率为例）

Set parameters (taking the total harmonic distortion rate of A-phase voltage as an example)

电压总谐波畸变率动作限值：默认 2.00%，范围 0~99.99%；

Voltage total harmonic distortion action limit: default 2.00%, range 0~99.99%;

电压总谐波畸变率动作延时：默认 5s，范围 1.00~99.99s；

Voltage total harmonic distortion action delay: default 5s, range 1.00~99.99s;

电压总谐波畸变率返回限值：默认 1.90%，范围 0~99.99%；

Voltage total harmonic distortion return limit: default 1.90%, range 0~99.99%;

电压总谐波畸变率返回延时：默认 5s，范围 1.00~99.99s；

Voltage total harmonic distortion return delay: default 5s, range 1.00~99.99s;

电压总谐波畸变率触发动作：无/DO1/DO2/DO3/DO4

Trigger action for total harmonic distortion rate of voltage: None/DO1/DO2/DO3/DO4

4) 记录参数（以 A 相电压总谐波畸变率为例）

Record parameters (taking the total harmonic distortion rate of A-phase voltage as an example)

越限发生时刻、A 相电压总谐波畸变率动作值；

The moment of exceeding the limit, and the action value of the total harmonic distortion rate of the A-phase voltage;

越限结束时刻、A 相电压总谐波畸变率返回值、越限期间 A 相电压总谐波畸变率最大值、越限持续时间。

End time of out-of-limit, return value of total harmonic distortion rate of A-phase voltage, maximum value of total harmonic distortion rate of A-phase voltage during the out-of-limit period, and duration of out-of-limit.

5) 其余参数越限原理同上，电压电流的总/奇次/偶次谐波均可独立设置对应定值。

The principle of exceeding limits of other parameters is the same as above. The total/odd/even harmonics of voltage and current can be independently set to corresponding fixed values.

3.5.2 电压偏差 Voltage deviation

供电系统在运行时，该点实际电压与系统标称电压之差对系统标称电压的百分数，称为该点的电压偏差，电压偏差分为电压上偏差和电压下偏差。数学表达式为：

During the operation of the power supply system, the percentage of the difference between the actual voltage at a given point and the system's nominal voltage, relative to the system's nominal voltage, is referred to as the voltage deviation at that point. Voltage deviation is divided into voltage upper deviation and voltage lower deviation. The mathematical expression is as follows:

电压偏差 Voltage deviation:

$$\text{电压偏差} = \frac{\text{实际电压} - \text{系统标称电压}}{\text{系统标称电压}} \times 100\%$$

$$\text{Voltage deviation} = \frac{\text{Actual voltage} - \text{System nominal electric}}{\text{System nominal voltage}} \times 100\%$$

电压上偏差 Upper deviation of voltage:

$$U_{\text{Over}}(\%) = \frac{\sqrt{\frac{\sum_{i=1}^n U_{\text{rms-over},i}^2}{n}} - U_{\text{din}}}{U_{\text{din}}} \times 100\%$$

其中 $U_{\text{rms-over},i}$ 为第 i 个 10 周波的有效值。

Where $U_{\text{rms-over},i}$ is the effective value of the i th 10-cycle wave.

$$U_{\text{rms-200ms},i} < U_{\text{din}}, \text{ 则, } U_{\text{rms-over},i} = U_{\text{din}}$$

$$U_{\text{rms-200ms},i} \geq U_{\text{din}}, \text{ 则, } U_{\text{rms-over},i} = U_{\text{rms-200ms},i}$$

电压下偏差 Voltage lower deviation:

$$U_{\text{under}}(\%) = \frac{U_{\text{din}} - \sqrt{\frac{\sum_{i=1}^n U_{\text{rms-under},i}^2}{n}}}{U_{\text{din}}} \times 100\%$$

其中 $U_{\text{rms-under},i}$ 为第 i 个 10 周波的有效值。

Where is the effective value of the the i 10-cycle wave.

$$U_{\text{rms-200ms},i} > U_{\text{din}}, \text{ 则, } U_{\text{rms-under},i} = U_{\text{din}}$$

$$U_{\text{rms-200ms},i} \leq U_{\text{din}}, \text{ 则, } U_{\text{rms-under},i} = U_{\text{rms-200ms},i}$$

35kV 及以上供电电压正、负偏差绝对值之和不超过标称电压的 10%。

The sum of the absolute values of the positive and negative deviations for power supply voltages of 35kV and above shall not exceed 10% of the nominal voltage.

20kV 及以下三相供电电压偏差为标称电压的 $\pm 7\%$ 。

The voltage deviation for three-phase power supply at 20kV and below is $\pm 7\%$ of the nominal voltage.

220V 单相供电电压偏差为标称电压的+7%, -10%。

The voltage deviation of 220V single-phase power supply is +7% and -10% of the nominal voltage.

装置获得电压有效值的基本测量时间窗口为 10 周波, 并且每个测量时间窗口接近而不重叠, 连续测量并计算电压有效值的平均值, 最终得到供电电压偏差值。

The basic measurement time window for the device to obtain the effective value of voltage is 10 cycles, and each measurement time window is close to but not overlapping. The average value of the effective voltage is continuously measured and calculated, and the final supply voltage deviation value is obtained.

本装置的电压测量精度为 $\pm 0.1\%$, 可实现对电压偏差的在线监测, 同时可设置越限告警与事件记录功能。

The voltage measurement accuracy of this device is $\pm 0.1\%$, enabling online monitoring of voltage deviations. Additionally, it can be configured with over-limit alarm and event recording functions.

表 3-8 电压偏差数据

Table 3-8 Voltage deviation data

测量值 measured value	单位 unit	测量值 measured value	单位 unit
Ua 电压上偏差 Ua voltage upper deviation	0.01%	Uab 电压上偏差 Uab voltage upper deviation	0.01%
Ub 电压上偏差 Upper deviation of Ub voltage	0.01%	Ubc 电压上偏差 Ubc voltage upper deviation	0.01%
Uc 电压上偏差 Uc voltage upper deviation	0.01%	Uca 电压上偏差 Uca voltage upper deviation	0.01%
Ua 电压下偏差 Ua voltage lower deviation	0.01%	Uab 电压下偏差 Uab voltage lower deviation	0.01%
Ub 电压下偏差 Ub voltage lower deviation	0.01%	Ubc 电压下偏差 Ubc voltage lower deviation	0.01%
Uc 电压下偏差 Uc voltage lower deviation	0.01%	Uca 电压下偏差 Uca voltage lower deviation	0.01%

➤ 电压偏差越上限 Voltage deviation exceeds the upper limit

(1) 电压偏差越上限分类: 包括 Ua/Ub/Uc/Uab/Ubc/Uca 共 6 类

Classification of voltage deviation exceeding the upper limit: including 6 categories: Ua/Ub/Uc/Uab/Ubc/Uca

(2) 判定方法 Judgment method

前置条件: 当实际电压大于系统标称电压时, 电压下偏差为 0, 计算可得到电压上偏差。

Precondition: When the actual voltage exceeds the system's nominal voltage, the voltage lower deviation is 0, and the voltage upper deviation can be calculated.

开始条件: 电压上偏差大于“电压偏差上限动作限值”, 且持续时间大于“电压偏差上限动作延时”。

Starting condition: The voltage upper deviation exceeds the "Upper Voltage Deviation Action Limit" and the duration exceeds the "Upper Voltage Deviation Action Delay".

结束条件: 电压上偏差恢复到小于“电压偏差上限返回限值”, 且持续时间大于“电压偏差上限返回延时”。

End condition: The voltage upper deviation returns to less than the "Voltage Deviation Upper Limit Return Limit" and the duration exceeds the "Voltage Deviation Upper Limit Return Delay".

(3) 设置参数 Set parameters

电压偏差上限动作限值: 默认 7.00%, 范围 0~99.99%;

Upper limit action value for voltage deviation: default 7.00%, range 0~99.99%;

电压偏差上限动作延时: 默认 5.00s, 范围 1.00~99.99s;

Upper voltage deviation limit action delay: default 5.00s, range 1.00~99.99s;

电压偏差上限返回限值: 默认 6.65%, 范围 0~99.99%;

Upper limit return value for voltage deviation: default 6.65%, range 0~99.99%;

电压偏差上限返回延时: 默认 5.00s, 范围 1.00~99.99s;

Upper voltage deviation return delay: default 5.00s, range 1.00~99.99s;

电压偏差上限触发动作类型: 无/DO1/DO2/DO3/DO4。

Upper voltage deviation limit triggers action types: None/DO1/DO2/DO3/DO4.

注：返回限值一般设置为动作限值的 0.95，下面其他事件同理。

Note: The return limit is generally set to 0.95 of the action limit. The same applies to other events below.

(4) 记录参数（以 Ua 为例） Record parameters (taking Ua as an example)

Ua 电压偏差越上限的发生时刻、Ua 电压上偏差的动作值；

The occurrence time of the Ua voltage deviation exceeding the upper limit, and the action value of the Ua voltage upper deviation;

Ua 电压偏差越上限的结束时刻、Ua 电压上偏差的返回值、越限过程中 Ua 电压上偏差最大值、越限的持续时间。

The end time of the Ua voltage deviation exceeding the upper limit, the return value of the Ua voltage upper deviation, the maximum value of the Ua voltage upper deviation during the exceeding process, and the duration of the exceeding.

(5) Ub、Uc、Uab、Ubc、Uca 同上 Ub, Uc, Uab, Ubc, and Uca are the same as above.

➤ 电压偏差越下限 Voltage deviation is below the lower limit

(1) 电压偏差越下限分类：包括 Ua/Ub/Uc/Uab/Ubc/Uca 共 6 类 Classification of voltage deviation below the lower limit: including 6 categories: Ua/Ub/Uc/Uab/Ubc/Uca

(2) 判定方法 Judgment method

前置条件：当实际电压小于系统标称电压时，电压上偏差为 0，计算可得到电压下偏差。

Precondition: When the actual voltage is less than the system's nominal voltage, the upper voltage deviation is 0, and the lower voltage deviation can be calculated.

开始条件：电压下偏差大于“电压偏差下限动作限值”，且持续时间大于“电压偏差下限动作延时”。

Starting condition: The voltage deviation is greater than the "voltage deviation lower limit action limit", and the duration is greater than the "voltage deviation lower limit action delay".

结束条件：电压下偏差恢复到小于“电压偏差下限返回限值”，且持续时间大于“电压偏差下限返回延时”。

End condition: The voltage deviation returns to less than the "voltage deviation lower limit return limit" and the duration is greater than the "voltage deviation lower limit return delay".

(3) 设置参数 Set parameters

电压偏差下限动作限值：默认 7.00%，范围 0~99.99%；

Lower limit action value for voltage deviation: default 7.00%, range 0~99.99%;

电压偏差下限动作延时：默认 5.00s，范围 1.00~99.99s；

Voltage deviation lower limit action delay: default 5.00s, range 1.00~99.99s;

电压偏差下限返回限值：默认 6.65%，范围 0~99.99%；

Lower limit return value for voltage deviation: default 6.65%, range 0~99.99%;

电压偏差下限返回延时：默认 5.00s，范围 1.00~99.99s；

Voltage deviation lower limit return delay: default 5.00s, range 1.00~99.99s;

电压偏差下限触发动作类型：无/DO1/DO2/DO3/DO4。

Trigger action type under voltage deviation lower limit: None/DO1/DO2/DO3/DO4.

(4) 记录参数（以 Ua 为例） Record parameters (taking Ua as an example)

Ua 电压偏差越下限的发生时刻、Ua 电压下偏差的动作值；

The occurrence time of the Ua voltage deviation reaching the lower limit, and the action value of the Ua voltage lower deviation;

Ua 电压偏差越下限的结束时刻、Ua 电压下偏差的返回值、越限过程中 Ua 电压下偏差的最大值、越限的持续时间。

The end time of the Ua voltage deviation exceeding the lower limit, the return value of the Ua voltage deviation below the lower limit, the maximum value of the Ua voltage deviation below the lower limit during the exceeding process, and the duration of the exceeding.

(5) Ub、Uc、Uab、Ubc、Uca 判定同上。 The determination of Ub, Uc, Uab, Ubc, and Uca is the same as above.

3.5.3 频率偏差 Frequency deviation

电力系统在正常运行条件下，系统频率的实际值和标称值之差，称为频率偏差。数学表达式为：

Under normal operating conditions of the power system, the difference between the actual value and the nominal value of the system frequency is called frequency deviation. The mathematical expression is:

$$\text{频率偏差} = \text{实际频率} - \text{标称频率}$$

$$\text{Frequency deviation} = \text{Actual frequency} - \text{Nominal frequency}$$

电力系统正常运行条件下频率偏差限值为 $\pm 0.2\text{Hz}$ 。当系统容量较小时，偏差限值可以放宽到 $\pm 0.5\text{Hz}$ 。冲击负荷引起的频率变动不得超过 $\pm 0.2\text{Hz}$ 。

Under normal operating conditions, the frequency deviation limit for the power system is $\pm 0.2\text{Hz}$. When the system capacity is relatively small, the deviation limit can be relaxed to $\pm 0.5\text{Hz}$. The frequency variation caused by impact load shall not exceed $\pm 0.2\text{Hz}$.

本装置的频率测量精度为 $\pm 0.005\text{Hz}$ ，可实现对频率偏差的在线监测，同时可设置越限告警与事件记录功能。

The frequency measurement accuracy of this device is $\pm 0.005\text{Hz}$, enabling online monitoring of frequency deviations. Additionally, it can be configured with over-limit alarm and event recording functions.

➤ 频率偏差越上限 Frequency deviation exceeds the upper limit

(1) 判定方法 Judgment method

前置条件：当实际频率大于标称频率时，频率偏差为正。

Precondition: When the actual frequency is greater than the nominal frequency, the frequency deviation is positive.

开始条件：频率偏差大于“频率偏差上限动作限值”（正值），且持续时间大于“频率偏差上限动作延时”。

Starting condition: The frequency deviation is greater than the "Upper limit action limit of frequency deviation" (positive value), and the duration is greater than the "Upper limit action delay of frequency deviation".

结束条件：频率偏差恢复到小于“频率偏差上限返回限值”（正值），且持续时间大于“频率偏差上限返回延时”。

End condition: The frequency deviation returns to less than the "Frequency Deviation Upper Limit Return Limit" (positive value), and the duration is greater than the "Frequency Deviation Upper Limit Return Delay".

(2) 设置参数 Set parameters

频率偏差上限动作限值：默认 0.20Hz，范围 0.01~9.99Hz；

Upper limit action value for frequency deviation: default 0.20Hz, range 0.01~9.99Hz;

频率偏差上限动作延时：默认 5.00s，范围 1.00~99.99s；

Upper limit action delay for frequency deviation: default 5.00s, range 1.00~99.99s;

频率偏差上限返回限值：默认 0.19Hz，范围 0.01~9.99Hz；

Upper limit return value for frequency deviation: default 0.19Hz, range 0.01~9.99Hz;

频率偏差上限返回延时：默认 5.00s，范围 1.00~99.99s；

Frequency deviation upper limit return delay: default 5.00s, range 1.00~99.99s;

频率偏差上限触发动作类型：无/波形记录/DO1/DO2/DO3/DO4。

Frequency deviation upper limit trigger action type: None/Waveform recording/DO1/DO2/DO3/DO4.

(3) 记录参数 Record parameters

频率偏差越上限发生时刻、频率偏差动作值（+）；

The moment when the frequency deviation exceeds the upper limit, the frequency deviation action value is (+);

频率偏差越上限结束时刻、频率偏差返回值（+）、越限过程中频率偏差最大值（+）、越限持续时间。

The end time of frequency deviation exceeding the upper limit, the return value of frequency deviation (+), the maximum value of

frequency deviation during the exceeding process (+), and the duration of exceeding.

➤ 频率偏差越下限 Frequency deviation below the lower limit

(1) 判定方法 Judgment method

前置条件: 当实际频率小于标称频率时, 频率偏差为负。

Precondition: When the actual frequency is less than the nominal frequency, the frequency deviation is negative.

开始条件: 频率偏差小于“频率偏差下限动作限值”(负值), 且持续时间大于“频率偏差下限动作延时”。

Starting condition: The frequency deviation is less than the "lower limit action limit of frequency deviation" (negative value), and the duration is greater than the "lower limit action delay of frequency deviation".

结束条件: 频率偏差恢复到大于“频率偏差下限返回延时”(负值), 且持续时间大于“频率偏差下限返回延时”。

End condition: The frequency deviation recovers to a value greater than the "Frequency Deviation Lower Limit Return Delay" (negative value), and the duration exceeds the "Frequency Deviation Lower Limit Return Delay".

(2) 设置参数 Set parameters

频率偏差下限动作限值: 默认-0.20Hz, 范围-0.01~-9.99Hz;

Lower limit action value for frequency deviation: default -0.20Hz, range -0.01 to -9.99Hz;

频率偏差下限动作延时: 默认 5.00s, 范围 0~99.99s;

Action delay for lower frequency deviation limit: default 5.00s, range 0~99.99s;

频率偏差下限返回限值: 默认-0.19Hz, 范围-0.01~-9.99Hz;

Lower limit return value for frequency deviation: default -0.19Hz, range -0.01~ -9.99Hz;

频率偏差下限返回延时: 默认 5.00s, 范围 1.00~99.99s;

Frequency deviation lower limit return delay: default 5.00s, range 1.00~99.99s;

频率偏差下限触发动作类型: 无/DO1/DO2/DO3/DO4。

Trigger action type for lower limit of frequency deviation: None/DO1/DO2/DO3/DO4.

(3) 记录参数 Record parameters

频率偏差越下限发生时刻、频率偏差动作值 (-); 频率偏差越下限结束时刻、频率偏差返回值 (-)、越限过程中频率偏差最小值 (-)、越限持续时间。

The moment when the frequency deviation reaches the lower limit, the action value of frequency deviation (-); the moment when the frequency deviation ends beyond the lower limit, the return value of frequency deviation (-), the minimum value of frequency deviation during the out-of-limit process (-), and the duration of out-of-limit.

3.5.4 不平衡和序分量测量 Unbalance and sequence component measurement

在理想的供电系统中, 三相电压或三相电流的幅值应相等, 相位应相差 120°。当实际系统偏离上述情况时, 就产生了不平衡问题及相应的电源利用效率降低的问题。如发电机和大型电动机, 负荷不平衡造成设备的不对称运行, 产生负序分量, 会引起设备过热和损耗, 缩短设备的使用寿命。分析三相系统的不平衡问题时, 可以用对称分量法对电压进行分解(电流算法相同):

In an ideal power supply system, the amplitude of three-phase voltage or current should be equal, and the phases should differ by 120°. When the actual system deviates from this condition, imbalance issues arise, leading to a decrease in power utilization efficiency. For example, in generators and large motors, unbalanced loads cause asymmetric operation of the equipment, generating negative-sequence components, which can cause equipment overheating and wear, thereby shortening the equipment's service life. When analyzing the imbalance issues in a three-phase system, the voltage can be decomposed using the symmetrical component method (the current algorithm is the same):

$$\text{对称分量法} \begin{cases} \text{零序分量 } \dot{U}_0 = \frac{1}{3}(\dot{U}_a + \dot{U}_b + \dot{U}_c) \\ \text{正序分量 } \dot{U}_1 = \frac{1}{3}(\dot{U}_a + a\dot{U}_b + a^2\dot{U}_c) \\ \text{负序分量 } \dot{U}_2 = \frac{1}{3}(\dot{U}_a + a^2\dot{U}_b + a\dot{U}_c) \end{cases}$$

对称分量法	Symmetrical component method	零序分量	Zero-sequence component
正序分量	Positive-sequence component	负序分量	Negative sequence component

本装置可实现对正序电压、负序电压、零序电压、正序电流、负序电流和零序电流的测量，三相对称时，只有正序分量，负序和零序分量都为0。而三相系统中的不平衡程度，可用不平衡度表示，具体表现为负序基波分量或零序基波分量与正序基波分量的有效值百分比，如下公式所示：

This device can measure positive-sequence voltage, negative-sequence voltage, zero-sequence voltage, positive-sequence current, negative-sequence current, and zero-sequence current. When the three phases are symmetrical, there is only a positive-sequence component, and both the negative-sequence and zero-sequence components are zero. The degree of imbalance in a three-phase system can be represented by the degree of imbalance, specifically expressed as the percentage of the effective value of the negative-sequence fundamental component or zero-sequence fundamental component relative to the positive-sequence fundamental component, as shown in the following formula:

(1) 电压、电流负序不平衡度 Negative sequence imbalance of voltage and current

$$u_2 = \frac{\text{电压负序分量}}{\text{电压正序分量}} \times 100\% \quad i_2 = \frac{\text{电流负序分量}}{\text{电流正序分量}} \times 100\%$$

$$u_2 = \frac{\text{Voltage negative sequence division}}{\text{Voltage positive sequence division}} \times 100\% \quad i_2 = \frac{\text{Current negative sequence division}}{\text{Current positive sequence division}} \times 100\%$$

(2) 电压、电流零序不平衡度 Zero-sequence imbalance degree of voltage and current

$$u_0 = \frac{\text{电压零序分量}}{\text{电压正序分量}} \times 100\% \quad i_0 = \frac{\text{电流零序分量}}{\text{电流正序分量}} \times 100\%$$

$$u_0 = \frac{\text{Voltage zero sequence division}}{\text{Voltage positive sequence division}} \times 100\% \quad i_0 = \frac{\text{Current zero sequence division}}{\text{Current positive sequence division}} \times 100\%$$

电网正常运行时，负序电压不平衡度不超过2%，短时不得超过4%。

During normal operation of the power grid, the negative-sequence voltage imbalance should not exceed 2%, and it should not exceed 4% for short periods.

接于公共连接点的每个用户引起该点负序电压不平衡度允许值一般为1.3%，短时不超过2.6%。

The allowable value of negative-sequence voltage imbalance caused by each user connected to the point of common coupling is generally 1.3%, with a short-term limit of no more than 2.6%.

本装置可实现对正序电压、负序电压、零序电压、正序电流、负序电流和零序电流的测量，并分别计算电压和电流的负序不平衡度及零序不平衡度，基本测量时间窗口为10个周期，如下表所示。

This device is capable of measuring positive-sequence voltage, negative-sequence voltage, zero-sequence voltage, positive-sequence current, negative-sequence current, and zero-sequence current. It also calculates the negative-sequence imbalance and zero-sequence imbalance of voltage and current separately. The basic measurement time window is 10 cycles, as shown in the table below.

表 3-9 三相不平衡测量参数

Table 3-9 Three-phase unbalance measurement parameters

测量值 (有效值) Measured value (effective value)	单位 Unit	分辨率 resolution
正序电压 U1 Positive-sequence voltage U1	V	0.001 V
负序电压 U2 Negative-sequence voltage U2	V	0.001 V
零序电压 U0 Zero-sequence voltage U0	V	0.001 V
正序电流 I1 Positive-sequence current I1	A	0.001 A
负序电流 I2 Negative-sequence current I2	A	0.001 A
零序电流 I0 Zero-sequence current I0	A	0.001 A
电压负序不平衡度 Voltage negative sequence imbalance	%	0.01%
电压零序不平衡度 Voltage zero-sequence imbalance	%	0.01%
电流负序不平衡度 Current negative sequence imbalance	%	0.01%
电流零序不平衡度 Current zero-sequence imbalance	%	0.01%

➤ 不平衡度越上限 Unbalance exceeds the upper limit

(1) 不平衡分类: 包括电压负序、电压零序、电流负序、电流零序共4类。

Unbalanced classification: including four categories: voltage negative sequence, voltage zero sequence, current negative sequence, and current zero sequence.

(2) 判定方法 (以电压负序为例) Judgment method (taking voltage negative sequence as an example)

正常情况下, 不平衡度应为0。

Under normal circumstances, the degree of imbalance should be 0.

开始条件: 电压负序不平衡度超过“电压负序不平衡度动作限值”, 且持续时间大于“电压负序不平衡度动作延时”。

Starting condition: The voltage negative sequence imbalance exceeds the "voltage negative sequence imbalance action limit" and the duration is greater than the "voltage negative sequence imbalance action delay".

结束条件: 电压负序不平衡度恢复到小于“电压负序不平衡度返回限值”, 且持续时间大于“电压负序不平衡度返回延时”。

End condition: The voltage negative-sequence imbalance degree returns to less than the "voltage negative-sequence imbalance degree return limit", and the duration is greater than the "voltage negative-sequence imbalance degree return delay".

(3) 设置参数 (以电压负序为例) Set parameters (taking voltage negative sequence as an example)

电压负序不平衡度动作限值: 默认 2.00%, 范围 0~99.99%;

Voltage negative sequence imbalance action limit: default 2.00%, range 0~99.99%;

电压负序不平衡度动作延时: 默认 5s, 范围 1.00~99.99s;

Voltage negative sequence imbalance action delay: default 5s, range 1.00~99.99s;

电压负序不平衡度返回限值: 默认 1.90%, 范围 0~99.99%;

Voltage negative sequence imbalance return limit: default 1.90%, range 0~99.99%;

电压负序不平衡度返回延时: 默认 5s, 范围 1.00~99.99s;

Voltage negative sequence imbalance return delay: default 5s, range 1.00~99.99s;

电压负序不平衡度触发动作: 无/DO1/DO2/DO3/DO4。

Voltage negative sequence imbalance triggers action: None/DO1/DO2/DO3/DO4.

(4) 记录参数 (以电压负序为例) Record parameters (taking voltage negative sequence as an example)

电压负序不平衡度超限发生时刻、电压负序不平衡度动作值; 电压负序不平衡度超限结束时刻、电压负序不平衡度返回值、超限过程中电压负序不平衡度最大值、超限持续时间。

The moment when the voltage negative-sequence imbalance exceeds the limit, the action value of voltage negative-sequence imbalance; the moment when the voltage negative-sequence imbalance exceeds the limit ends, the return value of voltage negative-sequence imbalance, the maximum value of voltage negative-sequence imbalance during the exceeding process, and the duration of exceeding.

(5) 电压零序、电流负序、电流零序原理同上, 且均可独立设置相应定值。

(5) The principles of voltage zero sequence, current negative sequence, and current zero sequence are the same as above, and corresponding fixed values can be independently set for each.

3.5.5 电压波动 Voltage fluctuation

在理想电力系统中, 供电电压应按照规定的参数稳定运行。但实际过程中, 由于外界的各种影响, 往往很难达到这个要求。而电压有效值的一系列变动或连续的改变, 称为电压波动。电压变动值为电压有效值的两个极值之差, 常以标称电压的百分数表示。单位时间内电压变动的次数, 称为电压变动频度。电压波动的计算公式如下:

In an ideal power system, the supply voltage should operate stably according to specified parameters. However, in practical processes, due to various external influences, it is often difficult to meet this requirement. A series of variations or continuous changes in the effective value of voltage is called voltage fluctuation. The voltage variation value is the difference between two extreme values of the effective voltage, often expressed as a percentage of the nominal voltage. The number of voltage variations per unit time is called the frequency of voltage variation. The calculation formula for voltage fluctuation is as follows:

$$\text{电压变动 } d = \frac{\Delta U}{U_N} = \frac{U_{\max} - U_{\min}}{U_N} \times 100\%$$

$$\text{电压变动频度 } r = \frac{\text{电压变动次数}}{\text{运行时间}}$$

电压变动	Voltage variation	电压变动频度	Voltage fluctuation frequency
电压变动次数	Number of voltage fluctuations	运行时间	Runtime

装置提供电压波动相关数据, 如下表:

The device provides data related to voltage fluctuations, as shown in the table below:

表 3-10 电压波动测量数据

Table 3-10 Voltage fluctuation measurement data

名称 Name	单位 Unit	分辨率 Resolution
Ua 电压波动 Ua voltage fluctuation	%	0.01%
Ub 电压波动 Ub voltage fluctuation	%	0.01%
Uc 电压波动 Uc voltage fluctuation	%	0.01%
Ua 电压变动频度	次/10 分钟	1

Ua voltage fluctuation frequency	Times/10 minutes	
Ub 电压变动幅度 Ub voltage fluctuation frequency	次/10 分钟 Times/10 minutes	1
Uc 电压变动幅度 Uc voltage fluctuation frequency	次/10 分钟 Times/10 minutes	1

注：电压波动每 10 分钟刷新，变动幅度每 10 分钟刷新。

Note: The voltage fluctuation and variation frequency are refreshed every 10 minutes.

3.5.6 电压闪变 Voltage flicker

闪变，一般是指人对白炽灯明暗变化的感觉，包括电压波动对电工设备的影响及危害。但不能以电压波动来代替闪变，因为闪变是人对照度波动的主观视感。衡量短时间（若干分钟）内闪变强弱的一个统计量值称为短时间闪变值 P_{st} ，短时间闪变的基本记录周期为 10min。由短时间闪变值推算出，反映长时间（若干小时）闪变强弱的量值称为长时间闪变值 P_{lt} ，长时间闪变的基本记录周期为 2h。

Flicker generally refers to the perception of people towards the brightness changes of incandescent lamps, including the impact and harm of voltage fluctuations on electrical equipment. However, voltage fluctuations cannot be used to replace flicker, as flicker is the subjective visual perception of people towards illumination fluctuations. A statistical value that measures the intensity of flicker within a short period of time (several minutes) is called the short-time flicker value P_{st} , and the basic recording period for short-time flicker is 10 minutes. Based on the short-time flicker value, a value that reflects the intensity of flicker over a long period of time (several hours) is calculated, which is called the long-time flicker value P_{lt} , and the basic recording period for long-time flicker is 2 hours.

闪变的主要决定因素如下。

The main determining factors of flicker are as follows.

- (1) 供电电压波动的幅值、频率和波形。

The amplitude, frequency, and waveform of power supply voltage fluctuations.

- (2) 照明装置。以对白炽灯的照度波形影响最大，而且与白炽灯的瓦数和额定电压等有关。

Lighting device. It has the greatest impact on the illuminance waveform of incandescent lamps, and is related to the wattage and rated voltage of the incandescent lamps.

- (3) 人对闪变的主观视感。由于人们视感的差异，需对观察者的闪变视感作抽样调查。

People's subjective perception of flicker. Due to differences in people's visual perception, a sampling survey of observers' perception of flicker is necessary.

➤ 闪变仪原理 Principle of flicker meter

本装置参考 IEC 闪变仪的推荐模型，模拟灯-眼-脑的过程，从而计算出短时间闪变值及长时间闪变值等参数。

This device refers to the recommended model of the IEC flicker meter, simulating the process of light-eye-brain, thereby calculating parameters such as short-term flicker value and long-term flicker value.



图 3-2 IEC 闪变仪模型的简化框图

Figure 3-2 Simplified block diagram of the IEC flicker meter model

框 1：电压适配，并产生标准调制波用于自检。

Box 1: Voltage adaptation, and generation of standard modulated waves for self-checking.

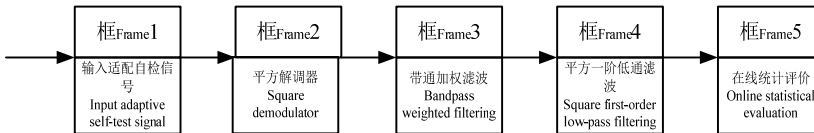
框 2: 模拟灯的作用。对电压信号进行平方处理。

Box 2: The role of the analog lamp. Square processing of voltage signals.

框 3: 模拟人眼的频率选择特性。带通加权滤波器反映了人对钨丝灯在不同频率的电压波动下照度变化的敏感程度, 通频带为 0.05Hz~35Hz (人对照度波动的最大觉察范围)。该功能可由 3 个滤波器串联组成:

Box 3: Simulating the frequency selection characteristics of the human eye. The bandpass weighted filter reflects the sensitivity of humans to changes in illuminance under voltage fluctuations of tungsten filament lamps at different frequencies, with a passband of 0.05Hz~35Hz (the maximum detection range of human perception to illuminance fluctuations). This function can be composed of three filters connected in series:

(1) 一阶高通滤波器, 截止频率为 0.05Hz, 抑制直流分量

A first-order high-pass filter with a cutoff frequency of 0.05Hz, which suppresses DC components

$$H(z) = \frac{0.9996(1 - z^{-1})}{1 - 0.9992z^{-1}}$$

(2) 六阶巴特沃斯低通滤波器, 截止频率为 35Hz, 移除 2 倍工频 (100Hz) 成分。若为 120V 60Hz 的系统, 则选择截止频率为 42Hz 的滤波器。与 (1) 结合可解调出反映电压波动的调幅波。

A sixth-order Butterworth low-pass filter with a cutoff frequency of 35Hz, which removes the 2-fold mains frequency (100Hz) component. For a 120V 60Hz system, a filter with a cutoff frequency of 42Hz should be selected. Combined with (1), it can demodulate the amplitude modulated wave reflecting voltage fluctuations.

$$H(z) = \frac{\sum_{k=0}^6 b_k z^{-k}}{1 + \sum_{k=1}^6 a_k z^{-k}}$$

式中 Where:

$a_1 = -3.8807$; $a_2 = 6.5355$; $a_3 = -6.0495$; $a_4 = 3.2276$; $a_5 = -0.9374$; $a_6 = 0.1155$;

$b_0 = 0.0002$; $b_1 = 0.0010$; $b_2 = 0.0026$; $b_3 = 0.0034$; $b_4 = 0.0026$; $b_5 = 0.0010$; $b_6 = 0.0002$ 。

(3) 视感度加权滤波器, 模拟人眼的频率选择特性。实际上是用传递函数 F(s) 逼近觉察率为 50% 的视感度曲线。

Visibility-weighted filter, which simulates the frequency selection characteristics of the human eye. In practice, it approximates the visibility curve with a transfer function F(s) at a detection rate of 50%.

$$F(s) = \frac{k\omega_1 s}{s^2 + 2\lambda s + \omega_1^2} \times \frac{1 + \frac{s}{\omega_2}}{\left(1 + \frac{s}{\omega_3}\right)\left(1 + \frac{s}{\omega_4}\right)}$$

参数 parameter	230V 灯 lamp	120V 灯 lamp
k	1.74802	1.6357
λ	$2\pi \times 4.05981$	$2\pi \times 4.167375$
ω_1	$2\pi \times 9.15494$	$2\pi \times 9.077169$
ω_2	$2\pi \times 2.27979$	$2\pi \times 2.939902$
ω_3	$2\pi \times 1.22535$	$2\pi \times 1.394468$
ω_4	$2\pi \times 21.9$	$2\pi \times 17.31512$

以 230V 灯为例, 将 F(s) 以双线性变换法从频域转换到 z 域, 如下所示:

Taking a 230V lamp as an example, F(s) is converted from the frequency domain to the z-domain using the bilinear transformation method, as shown below:

$$s = \frac{2(1 - z^{-1})}{1 + z^{-1}}$$

$$H(z) = \frac{\sum_{k=0}^4 b_k z^{-k}}{1 + \sum_{k=1}^4 a_k z^{-k}}$$

式中 Where:

T 为采样周期 T represents the sampling period;

$a_1 = -3.548754$; $a_2 = 4.714548$; $a_3 = -2.776010$; $a_4 = 0.610325$;

$b_0 = 0.009351$; $b_1 = 0.000329$; $b_2 = -0.018373$; $b_3 = -0.000329$; $b_4 = 0.009022$ 。

修正系数: 根据不同系统参数对短时閃爍变值或长时閃爍变值进行修正。

Correction factor: Adjust the short-term flicker value or long-term flicker value based on different system parameters.

220V, 50Hz 的系统参考 230V, 50Hz 的结果乘以修正系数 0.97;

For a 220V, 50Hz system, the result of a 230V, 50Hz system should be multiplied by a correction factor of 0.97;

100V, 50Hz 的系统参考 120V, 50Hz 的结果乘以修正系数 0.90;

For a 100V, 50Hz system, the result of a 120V, 50Hz system should be multiplied by a correction factor of 0.90;

100V, 60Hz 的系统参考 120V, 60Hz 的结果乘以修正系数 0.90。

For a 100V, 60Hz system, the results of a 120V, 60Hz system should be multiplied by a correction factor of 0.90.

框 4: 模拟人脑神经对视觉反映和记忆效应。包含了一个平方器和时间常数为 300ms 的低通滤波器, 用来模拟灯-眼-脑环节对灯光照度变化的暂态非线性响应和记忆效应。输出的 S(t) 反映了人的视觉对电压波动的瞬时閃爍感觉水平。

Box 4: Simulating human brain neural responses and memory effects to vision. It includes a squarer and a low-pass filter with a time constant of 300ms, which are used to simulate the transient nonlinear response and memory effect of the lamp-eye-brain pathway to changes in light intensity. The output S(t) reflects the instantaneous flicker perception level of human vision to voltage fluctuations.

(1) 平方计算, 模拟人脑神经对视觉反映的非线性过程。

Square calculation, simulating the nonlinear process of human brain neurons responding to visual stimuli.

(2) 平滑平均, 模拟人脑记忆效应, 由时间常数为 300ms 的一阶低通滤波器实现。

Smoothing and averaging, simulating the human brain memory effect, is achieved by a first-order low-pass filter with a time constant of 300ms.

$$H(z) = \frac{0.26471(1 + z^{-1})}{1 - 0.99170z^{-1}}$$

框 5: 对输入的 S(t) 值用累积概率函数 CPF 的方法进行分析, 即横坐标表示被测量, 纵坐标表示超过对应横坐标的时间占整个测量时间的百分数。通常在 10min 内进行统计, 实际仪器分级数应不小于 64 级。

Box 5: Analyze the input S(t) value using the Cumulative Probability Function (CPF) method, where the horizontal axis represents the measured quantity, and the vertical axis represents the percentage of time during which this quantity exceeds the corresponding horizontal axis value within the total measurement period. Statistics are typically compiled over a 10-minute period, and the actual number of levels for the instrument should be no less than 64.

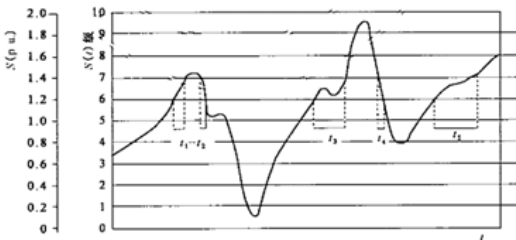

(a) S(t) 曲线 S(t) curve

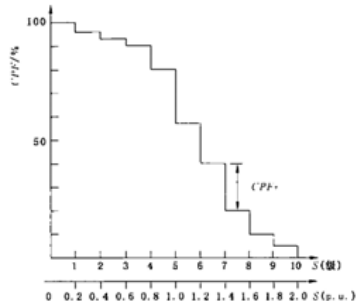

(b) CPF 曲线 CPF curve

图 3-3 由 S(t)作出 CPF 曲线示例

Figure 3-3 Example of generating CPF curve from S(t)

➤ 计算公式 calculation formula

$$\text{短时间闪变值 } P_{st} = \sqrt{0.0314P_{0.1} + 0.0525P_1 + 0.0657P_3 + 0.28P_{10} + 0.08P_{50}}$$

$$\text{长时间闪变值 } P_{lt} = \sqrt[3]{\frac{1}{12} \sum_{j=1}^{12} (P_{stj})^3}$$

$$\text{Short term severity } P_{st} = \sqrt{0.0314P_{0.1} + 0.0525P_1 + 0.0657P_3 + 0.28P_{10} + 0.08P_{50}}$$

$$\text{Loog term severity } P_{lt} = \sqrt[3]{\frac{1}{12} \sum_{j=1}^{12} (P_{stj})^3}$$

➤ 式中 Where:

$P_{0.1}$ 、 P_1 、 P_3 、 P_{10} 、 P_{50} 分别为 CPF 曲线上等于 0.1%、1%、3%、10%、50% 时间的 S(t)值;

$P_{0.1}$ 、 P_1 、 P_3 、 P_{10} 、 P_{50} The values on the CPF curve correspond to the times when it equals 0.1%, 1%, 3%, 10%, and 50%, respectively;S(t)

P_{stj} 为 2h 内第 j 个短时间闪变值。

P_{stj} It is the j-th short-time flicker value within 2 hours.

➤ 平滑处理 smoothing

为防止突变值带来的误差, 可进行如下平滑处理。而 300ms 的存储时间常数保证了 $P_{0.1}$ 不会突变, 故 $P_{0.1}$ 无需处理。

To prevent errors caused by abrupt values, the following smoothing process can be applied. However, the storage time constant of 300ms ensures that $P_{0.1}$ there will be no abrupt changes, so $P_{0.1}$ no further processing is necessary.

$$P_{1s} = \frac{(P_{0.7} + P_1 + P_{1.5})}{3}$$

$$P_{3s} = \frac{(P_{2.2} + P_3 + P_4)}{3}$$

$$P_{10s} = \frac{(P_6 + P_8 + P_{10} + P_{13} + P_{17})}{5}$$

$$P_{50s} = \frac{(P_{30} + P_{50} + P_{80})}{3}$$

➤ 分级器 Grader

计算 P_{st} 所要求的特定百分点的 P_k 值, 一般并不会正好对应单一等级, 可根据如下方法提高准确度。

The value of P_{st} a specific percentage point required for calculation P_k generally does not correspond to a single grade exactly. The accuracy can be improved according to the following methods.

(1) 线性内插法 Linear interpolation method

$$P_k = \frac{F_s}{N} \left(n - \frac{y_k - y_n}{y_{n-1} - y_n} \right)$$

式中 Where:

F_s 为分级器量程, 即 S(t) 的取值范围;

F_s represents the range of the classifier, which is the value range of S(t);

N 为等分级数;

N represents the number of equal grades;

$\frac{F_s}{N}$ 为每一级的宽度;

$\frac{F_s}{N}$ The width of each level;

y_n 为对应于等级 n 的百分数概率值;

y_n It corresponds to the percentage probability value of level n ;

y_k 为 P_k 所对应的百分数, 如 0.1%、1%、3%、10%、50%;

y_k The corresponding percentages, such as P_k 0.1%, 1%, 3%, 10%, and 50%;

P_k 落在 $n-1$ 级与 n 级之间。

P_k Fall between the $n-1$ level and the n level.

(2) 非线性内插法 Nonlinear interpolation method

当线性内插法不能给出足够的准确度时, 应采用非线性内插法。

When linear interpolation fails to provide sufficient accuracy, nonlinear interpolation should be employed.

$$P_k = \frac{F_s}{N} (n - 1 + \frac{1}{2H_2} (H_1 - \sqrt{H_3}))$$

式中 Where:

$$H_1 = \frac{3}{2}y_{n-1} - 2y_n + \frac{1}{2}y_{n+1};$$

$$H_2 = \frac{1}{2}y_{n-1} - y_n + \frac{1}{2}y_{n+1};$$

$$H_3 = H_1^2 - 4H_2(y_{n-1} - 2y_k);$$

(3) 伪零截取 Pseudo-zero truncation

当 P_k 位于第一级区间内时, 内插值法在第一级的零点和其上终点之间的效果可能不好, 减少误差的一种方法为提供伪零截取值。

When P_k located within the first level interval, the interpolation method may not perform well between the zero point of the first level and its upper endpoint. One method to reduce error is to provide a pseudo-zero intercept value.

$$y_0 = (3y_1 - 3y_2 + y_3)$$

(4) 非线性分级 Nonlinear classification

等级区间在宽度上渐变, 可以使分级器更有效、更准确, 还可避免伪零点延拓, 如对数分级、线性插值。

Gradual changes in the width of the grade interval can make the grading device more effective and accurate, and can also avoid false zero extension, such as logarithmic grading and linear interpolation.

➤ 测量数据 Measurement data

表 3-11 闪变测量数据

Table 3-11 Flicker Measurement Data

名称 Name	单位 Unit	分辨率 Resolution
Ua 短时间闪变值 Ua short-time flicker value	--	0.001
Ub 短时间闪变值 Ub short-time flicker value	--	0.001
Uc 短时间闪变值 Uc short-time flicker value	--	0.001
Ua 长时间闪变值 Ua long-duration flicker value	--	0.001
Ub 长时间闪变值 Ub long-time flicker value	--	0.001

Uc 长时间闪变值 Uc long-term flicker value	--	0.001
---	----	-------

➤ 闪变超限 Flicker exceeds the limit

(1) 闪变分类: 包括 A 相、B 相、C 相的短时闪变值和长时闪变值

Flicker classification: including short-term flicker values and long-term flicker values of phase A, phase B, and phase C

(2) 判定方法 (以 A 相短时闪变为例)

Judgment method (taking short-term flicker of phase A as an example)

开始条件: A 相短时间闪变值超过“短时闪变限值”。

Initial condition: The short-term flicker value of Phase A exceeds the "short-term flicker limit".

P_n	
≤ 110 kV	> 110 kV
1	0.8

图 3-6 国标推荐闪变限值

Figure 3-6: Recommended flicker limits according to national standards

(3) 设置参数 Set parameters

短时闪变限值: 默认 1, 范围 0~99.99;

Short-term flicker limit: default value 1, range 0~99.99;

长时闪变限值: 默认 1, 范围 0~99.99;

Long-term flicker limit: default 1, range 0~99.99;

闪变触发动作: 无/DO1/DO2/DO3/DO4。

Flicker trigger action: None/DO1/DO2/DO3/DO4.

(4) 记录参数 (以 A 相短时闪变为例) Record parameters (taking short-term flicker of Phase A as an example)

闪变超限时刻、A 相短时闪变动作值。Flicker threshold crossing time, A-phase short-term flicker action value.

(5) 其他参数同上, 短时闪变限值与长时闪变限值可独立设定。Other parameters are the same as above, and the short-term flicker limit and long-term flicker limit can be set independently.

3.5.7 电压快速变动 Rapid voltage variation

用电设备工作电流的变动而造成配电网电压变动或波动, 可能导致照明闪烁的现象。快速电压变动是 RMS 电压在两个稳态之间 (不超过暂升暂降阈值) 的快速转换。

Voltage variations or fluctuations in the distribution network caused by changes in the operating current of electrical equipment may lead to the phenomenon of lighting flickering. Rapid voltage variations refer to the rapid transition of RMS voltage between two steady states (within the limits of the temporary rise and fall thresholds).

装置提供电压快速变动捕捉功能。电压快速变动反映了电压有效值在两个稳态之间, 电压幅值的变化情况。电压快速变动是在稳定电压容差、稳定时间、所检测到的最小步长, 及最小变化速度 (%/s) 的基础上捕获。图 4-2 对此做出解释。当电压变化超过暂升暂降的阈值时, 它被视为暂升或暂降, 而不是电压快速变动。根据 Norwegian FoL 中电压快速变动的定义, 通过电压阶跃 (Vstep), 最大电压变化 (Vmax), 以及电压变化速率来检测。当电压阶跃 (Vstep)、电压变化速度均大于限值, 并且电压变化不超过暂态阈值时认为发生了电压快速变动。电压快速变动事件存入 PQ 事件, 记录电压阶跃变化及变化持续时间以及相对于标称电压的最大电压变化 Vmax。

The device provides a function to capture rapid voltage variations. Rapid voltage variations reflect the changes in voltage amplitude between two steady states in terms of effective voltage values. Rapid voltage variations are captured based on stable voltage tolerance, stabilization time, the minimum step size detected, and the minimum change rate (%/s). Figure 4-2 explains this. When the voltage change

exceeds the threshold for temporary voltage dips and surges, it is considered as a temporary dip or surge, rather than a rapid voltage variation. According to the definition of rapid voltage variations in Norwegian FoL, rapid voltage variations are detected through voltage steps (Vstep), maximum voltage change (Vmax), and voltage change rate. Rapid voltage variations are considered to have occurred when both the voltage step (Vstep) and voltage change rate are greater than the limit values, and the voltage change does not exceed the transient threshold. Rapid voltage variation events are stored in PQ events, recording the voltage step change, change duration, and the maximum voltage change Vmax relative to the nominal voltage.



图 3-4 电压快速变动

Figure 3-4 Rapid voltage variation

电压容差 (voltage tolerance)

- (1) 判断一段时间内电压是否达到稳态的限值，电压容差 (voltage tolerance) 一般表示为额定电压的百分比形式。

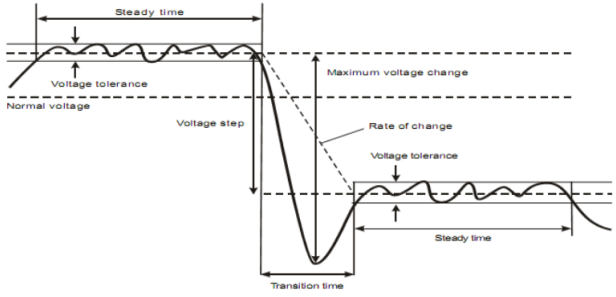
To determine whether the voltage reaches the steady-state limit within a certain period of time, the voltage tolerance is generally expressed as a percentage of the rated voltage.

$$\text{稳态电压容差} = \frac{\text{稳态允许的最大电压波动值}}{\text{额定电压}} \times 100\%$$

$$\text{Steady state voltage tolerance} = \frac{\text{maximum allowable voltage fluctuation in steady state}}{\text{Rated voltage}} \times 100\%$$

稳态时间 (Steady time)

- (2) 电压进入稳态后所持续的时间称为稳态时间。

The duration of time after the voltage enters a steady state is called the steady-state time.

电压阶跃 (Voltage step)

- (3) 在一次快速电压变动中，前一次稳态值与当前稳态值之差，称为电压阶跃，通常以额定电压的百分比表示。

In a rapid voltage fluctuation, the difference between the previous steady-state value and the current steady-state value is referred to as a voltage step, typically expressed as a percentage of the rated voltage.

$$\text{电压阶跃} = \frac{|\text{前稳态值} - \text{现稳态值}|}{\text{额定电压}} \times 100\%$$

$$\text{Voltage step} = \frac{|\text{pre steady state value} - \text{current steady state value}|}{\text{Rated voltage}} \times 100\%$$

转变时间 (Transition time)

- (4) 快速电压变动的转变时间为脱离前一稳态的时刻到进入后一稳态时刻之间的时间。

The transition time of rapid voltage variation refers to the time period between the moment when the previous steady state is left and the moment when the subsequent steady state is entered.

变化速率 (Rate of change)

- (5) 电压变化速率等于电压阶跃与转变时间的比值，为单位时间内电压变化的幅度。

The rate of voltage change is equal to the ratio of voltage step to transition time, representing the magnitude of voltage change per unit time.

$$\text{电压变化速率} = \frac{\text{电压阶跃}}{\text{转变时间}} \quad (\%/s)$$

$$\text{Voltage change rate} = \frac{\text{voltage step}}{\text{transition time}} \quad (\%/s)$$

最大电压变动 (Maximum voltage change)

- (6) 一次电压变动全过程中，电压相对于前一次稳态值的最大变化值占额定电压的百分比，称为最大电压变动，结束标志为新的稳态建立或观测时间结束。

During the entire process of a voltage variation, the maximum change in voltage relative to the previous steady-state value, expressed as a percentage of the rated voltage, is referred to as the maximum voltage variation. The end is marked by the establishment of a new steady state or the end of the observation period.

$$\text{最大电压变动} = \frac{\max(|\text{前稳态值} - \text{新电压值 } 1|, |\text{前稳态值} - \text{新电压值 } 2|, \dots)}{\text{额定电压}} \times 100\%$$

$$\text{Maximum voltage variation} = \frac{\max(|\text{pre steady state value} - \text{new voltage value } 1|, |\text{pre steady state value} - \text{new voltage value } 2|, \dots)}{\text{Rated voltage}} \times 100\%$$

电压稳态 Steady voltage

- (7) 在稳态时间 (Steady time) 内电压有效值的波动在电压容差 (Voltage tolerance) 范围内则认为是一个电压稳态。即在稳态时间 (Steady time) 内满足：

If the fluctuation of the effective voltage value within the steady time remains within the voltage tolerance range, it is considered as a voltage steady state. That is, during the steady time, the following condition is met:

$$\frac{ABS(U_{\max} - U_{\min})}{U_n} < \delta$$

其中,为稳态时间 (Steady time) 内电压有效值的最大值最小值, 为额定电压, 为电压容差 (voltage tolerance)

Where U_{\max} , U_{\min} is the maximum and minimum value of the effective voltage during steady time, U_n is the rated voltage, δ and is the voltage tolerance

- (8) 电压快速变动捕捉条件 Capture conditions for rapid voltage fluctuations

- 电压阶跃大于电压阶跃参数值/最大电压变化大于电压阶跃参数值 (基于不同的探测模式)
- The voltage step exceeds the voltage step parameter value / the maximum voltage change exceeds the voltage step parameter value (based on different detection modes)
- 电压变化速率大于电压变化速率参数值
- The voltage change rate is greater than the voltage change rate parameter value
- 快速电压变动过程中电压值不超过暂态阈值, 否则认为发生了暂升暂降事件。
- During rapid voltage fluctuations, the voltage value should not exceed the transient threshold; otherwise, it is considered that a transient voltage rise or fall event has occurred.
- 快速电压变动可同时触发两个输出, 输出包括: DO 出口、波形记录、扰动记录, 有效值记录。
- Rapid voltage fluctuations can trigger two outputs simultaneously, including DO output, waveform recording, disturbance recording, and effective value recording.

- (9) 参数设置如下 The parameter settings are as follows:

- 投退：投入/退出，默认退出；
- Join/Leave: Join/Leave, default is Leave;
- 阈值：0.2%~10%的额定电压，默认 5%；
- Threshold: 0.2% to 10% of rated voltage, default 5%;
- 迟滞：0.1%~5%的额定电压，默认 2.5%；
- Hysteresis: 0.1% to 5% of rated voltage, default 2.5%;
- 触发参数：DO 出口、波形记录、扰动记录、有效值记录；
- Trigger parameters: DO outlet, waveform recording, disturbance recording, effective value recording;
- 设置方式：装置面板、通过通信由上位机软件进行设置。
- Setting method: The device panel and the upper computer software can be used for setting through communication.

3.6 暂态电能质量监测功能 Transient power quality monitoring function

3.6.1 电压暂升暂降及中断 Voltage dips, spikes, and interruptions

电力系统中某点电压暂时升高至标称电压的 110%~180%之间，并在短暂持续后恢复正常的现象，称为电压暂升。某点工频电压有效值突然下降至标称电压的 10~90%，并在短暂持续后恢复正常，称为电压暂降。某点工频电压有效值突然下降至标称电压的 10%以下，并在短暂持续后恢复正常，称为短时中断。暂态事件的持续时间通常在 10ms~1min 之间。电压暂降或者短时中断过程中记录的电压方均根值的最小值称为残余电压，与之对应的，电压暂升过程中任一通道上测得的电压有效值的最大值称为最大暂升电压。深度为标称电压与残余电压或最大暂升电压之间的差值，以标称电压的百分数表示。迟滞电压为起点电压阈值与终点电压阈值之间的差值。

The phenomenon where the voltage at a certain point in the power system temporarily rises to between 110% and 180% of the nominal voltage and returns to normal after a brief duration is called voltage sag. When the effective value of the power frequency voltage at a certain point suddenly drops to 10% to 90% of the nominal voltage and returns to normal after a brief duration, it is referred to as voltage sag. When the effective value of the power frequency voltage at a certain point suddenly drops below 10% of the nominal voltage and returns to normal after a brief duration, it is called short interruption. The duration of transient events is usually between 10ms and 1min. The minimum value of the root-mean-square voltage recorded during a voltage sag or short interruption is called residual voltage. Correspondingly, the maximum value of the effective voltage measured on any channel during a voltage sag is called maximum sag voltage. The depth is the difference between the nominal voltage and the residual voltage or the maximum sag voltage, expressed as a percentage of the nominal voltage. The hysteresis voltage is the difference between the starting voltage threshold and the ending voltage threshold.

本装置针对电压暂升暂降、电压短时中断的具体功能如下：

The specific functions of this device for voltage sag and swell, as well as short-term voltage interruptions, are as follows:

- 每相电压均可启动暂升/暂降、中断事件；
- Each phase voltage can trigger events such as voltage dips/swells and interruptions;
- 记录每一次电压暂升/暂降和中断发生时刻、持续时间、深度等详细数据；
- Record detailed data such as the occurrence time, duration, and depth of each voltage sag/swell and interruption;

本装置暂态相关的参数设置有：

The parameter settings related to the transient state of this device are as follows:

- 投退：暂态可设置投入或者退出，默认投入；
- Activation/Deactivation: The transient state can be set to be activated or deactivated, with activation as the default;
- 暂态参考电压：额定电压/滑动参考电压，默认额定电压；
- Transient reference voltage: rated voltage/sliding reference voltage, default rated voltage;

- 电压暂升限值：默认 110%，范围 110%~200%；
- Voltage transient rise limit: default 110%, range 110% to 200%;
- 电压暂降限值：默认 90%，范围 10%~90%；
- Voltage sag limit: default 90%, range 10% to 90%;
- 电压中断限值：默认 10%，范围 1~10%；
- Voltage interruption limit: default 10%, range 1-10%;
- 暂态迟滞值：默认 2%，范围 0.5%~10%；
- Transient hysteresis value: default 2%, range 0.5% to 10%;
- 触发动作类型：DO 出口、波形记录、扰动记录、有效值记录。
- Trigger action type: DO output, waveform recording, disturbance recording, effective value recording.
- 设置方式：装置面板、通过通信由上位机软件进行设置。
- Setting method: The device panel can be set through communication with the host computer software.

3.6.2 电压事件标记 Voltage event marking

装置提供电压事件标记功能。当发生电压暂降、暂升、中断事件时，装置对电压事件发生时刻的频率、闪变、电压幅值、不平衡、谐波测量结果，做出标记。标记的作用是，电压波动与闪变合格率评估时，避免暂态事件的影响，准确评估闪变值；电压合格率评估时，有效避免对电压中断事件的计算，准确评估供电电压幅值；谐波合格率评估时，有效避免仪器分析计算错误以及不合理测量结果，准确评估谐波水平。

The device provides voltage event marking functionality. When voltage sag, swell, or interruption events occur, the device marks the measurement results of frequency, flicker, voltage amplitude, imbalance, and harmonics at the time of the voltage event. The purpose of marking is to avoid the impact of transient events when evaluating the pass rate of voltage fluctuation and flicker, accurately assessing the flicker value; to effectively avoid calculating voltage interruption events when evaluating the voltage pass rate, accurately assessing the supply voltage amplitude; and to effectively avoid analytical and computational errors of instruments and unreasonable measurement results when evaluating the harmonic pass rate, accurately assessing the harmonic level.

3.7 瞬态电能质量监测功能 Transient power quality monitoring function

由于瞬态事件变化太快，为提示发生过瞬态告警事件，在瞬态告警发生后，其告警状态字会延时 1 分钟后恢复，不随实际状态立即恢复。

Due to the rapid changes in transient events, to indicate the occurrence of a transient alarm event, the alarm status word will be restored after a delay of 1 minute after the transient alarm occurs, rather than immediately restoring it based on the actual status.

3.7.1 瞬态过电压捕捉 Transient overvoltage capture

装置具有较强的瞬态捕捉能力，捕捉小于 0.5 周波的电压瞬变：

The device exhibits strong transient capture capability, capable of capturing voltage transients shorter than 0.5 cycles:

A) 可捕捉最短达 20 μ s 的子周波瞬变；

Capable of capturing sub-cycle transients as short as 20 μ s;

B) 每次捕捉到瞬变，可触发波形记录、扰动记录；

Each time a transient is captured, waveform recording and disturbance recording can be triggered;

C) 记录每一次电压瞬变发生时刻、瞬变的深度和持续时间等详细数据。

Record detailed data such as the occurrence time, depth, and duration of each voltage transient.

瞬态相关的参数设置有：

The parameter settings related to transient state for are as follows:

投退：瞬态可设置投入或者退出，默认退出；

Activation/Deactivation: Instantaneous activation or deactivation can be set, with deactivation as the default;

- 瞬态捕捉限值：默认 0.35，范围 0.05~5 倍额定电压；
- Transient capture limit: default 0.35, range 0.05~5 times rated voltage;
- 触发参数：波形记录、扰动记录、有效值记录；
- Trigger parameters: waveform recording, disturbance recording, effective value recording;
- 设置方式：装置面板、通过通信由上位机软件进行设置。
- Setting method: The device panel and the upper computer software through communication.

3.7.2 突变量检测 Abrupt change detection

装置提供电压突变量、电流突变量检测功能，用于监测电压、电流运行时参数突变故障告警，快速响应动作，可根据实际情况需要分别设置电压突变量、电流突变量的功能投退及动作限值。突变量事件动作记入监测事件，记录发生时间、动作相别及突变量变化值，并可设置触发 DO 动作、波形记录、扰动记录、有效值记录，触发事件也记录在监测事件中。相关设置参数如下：

The device provides voltage and current mutation detection functions for monitoring voltage and current parameter mutation faults during operation and triggering quick response actions. The activation and deactivation of voltage and current mutation functions, as well as the action limits, can be set according to actual needs. Mutation event actions are recorded in monitoring events, including the occurrence time, action phase, and mutation change value. It is also possible to set triggers for DO actions, waveform recording, disturbance recording, and effective value recording. Triggered events are also recorded in monitoring events. The relevant setting parameters are as follows:

- 投退：投入/退出，默认退出。
- Join/Leave: Join/Leave, default is Leave.
- 电压突变量限值 (ΔU)：默认 100V，范围 0.57~100.00V
- Voltage mutation limit (ΔU): default 100V, range 0.57~100.00V
- 电流突变量限值 (ΔI)：默认 5A，范围 0.10~5.00A
- Current jump limit (ΔI): default 5A, range 0.10~5.00A
- 触发动作：DO 出口、波形记录、扰动记录、有效值记录；
- Trigger action: DO output, waveform recording, disturbance recording, effective value recording;
- 设置方式：装置面板、通过通信由上位机软件进行设置。
- Setting method: The device panel can be set through communication with the host computer software.

3.8 电能质量统计功能 Power quality statistics function

3.8.1 统计定时记录 Statistical timing records

装置具有超强的统计定时记录功能，可对实时测量 3s 值按照设定的间隔时间进行统计计算，并记录统计值，包括间隔时间内的最大值、最小值、平均值、95%概率值。统计数据的存储格式为 PQDIF 格式，间隔时间固定 3min。可保存 90 天的统计数据，掉电数据不丢失。数据存储方式采用循环记录方式，当记存满后覆盖最早的记录数据。

The device boasts an exceptional statistical timing recording function. It can perform statistical calculations on real-time measured 3s values at preset intervals and record the statistical values, including the maximum, minimum, average, and 95% probability values within the interval. The statistical data is stored in PQDIF format with a fixed interval of 3 minutes. It can store statistical data for 90 days, and the data is not lost in case of power failure. The data storage method employs a circular recording approach, overwriting the oldest recorded data when the storage is full.

3.9 越限监测与控制功能 Off-limit monitoring and control function

3.9.1 越限监测 Out-of-limit monitoring

本装置提供测量参数越限监测功能，判断各种电气量是否超过设定的限值，越限可触发告警及 SOE 事件记录。具体定值均可进行设定，且只能通过通讯由上位机软件进行设定，相关参数如下表所示：

This device provides an over-limit monitoring function for measurement parameters, which determines whether various electrical quantities exceed the set limits. An over-limit condition can trigger an alarm and SOE event recording. Specific setting values can be configured, and they can only be set through communication via the host computer software. The relevant parameters are listed in the table below:

表 3-12 定值越限监测参数

Table 3-12: Monitoring Parameters with Fixed Value Out-of-Limit

类别 Category	越限监测对象 Objects under off-limit monitoring
电压偏差 Voltage deviation	电压偏差 Voltage deviation
频率偏差 Frequency deviation	频率偏差 Frequency deviation
电流越限 Current out of limit	Ia、Ib、Ic
功率越限 Power exceeding the limit	P_{ϕ} 、Pa、Pb、Pc P_{total} 、Pa、Pb、Pc
功率因数越限 Power factor out of limit	PF_{ϕ} 、PFa、PFb、PFc PF _{Total} 、PFa、PFb、PFc
三相不平衡 Three-phase unbalance	电压负序不平衡度、电压零序不平衡度、电流负序不平衡度、电流零序不平衡度 Voltage negative-sequence imbalance, voltage zero-sequence imbalance, current negative-sequence imbalance, current zero-sequence imbalance
谐波 Harmonic	电压总谐波畸变率、电流总谐波畸变率、电压偶次谐波畸变率、电流偶次谐波畸变率、电压奇次谐波畸变率、电流奇次谐波畸变率，2~63 次电压谐波含有率，2~63 次电流谐波有效值 Total harmonic distortion rate of voltage, total harmonic distortion rate of current, even-order harmonic distortion rate of voltage, even-order harmonic distortion rate of current, odd-order harmonic distortion rate of voltage, odd-order harmonic distortion rate of current, 2nd to 63rd order voltage harmonic content, and 2nd to 63rd order current harmonic effective value
间谐波 Inter-harmonic	电压总间谐波畸变率、电流总间谐波畸变率、电压偶次间谐波畸变率、电流偶次间谐波畸变率、电压奇次间谐波畸变率、电流奇次间谐波畸变率， Total voltage inter-harmonic distortion rate, total current inter-harmonic distortion rate, even-order voltage inter-harmonic distortion rate, even-order current inter-harmonic distortion rate, odd-order voltage inter-harmonic distortion rate, odd-order current inter-harmonic distortion rate,
闪变 Flicker	短时间闪变值、长时间闪变值 Short-term flicker value, long-term flicker value

(1) 动作值与返回值 Action value and return value:

越上限时，测量值大于动作上限时越限动作，小于动作复归值时越限返回；

When exceeding the upper limit, if the measured value is greater than the action upper limit, an out-of-limit action is triggered; if it is less than the action reset value, the out-of-limit status is returned;

越下限时，测量值小于动作下限时越限动作，大于动作复归值时越限返回。

When the measurement value is below the lower limit, it triggers an off-limit action. When it exceeds the action reset value, the off-limit status returns to normal.

(2) 动作延时: 设定范围为 1.00~99.99s 。Action delay: The setting range is 1.00~99.99s.

当测量参数超过限值, 且持续时间大于动作延时时, 继电器动作。

When the measured parameter exceeds the limit and the duration is greater than the action delay, the relay will actuate.

(3) 返回延时: 设定范围为 1.00~99.99s。Return delay: The setting range is 1.00~99.99s.

当测量参数恢复正常, 且持续时间大于返回延时时, 继电器返回。

When the measured parameter returns to normal and the duration exceeds the return delay, the relay returns.

(4) 所有越限动作及返回都会触发 SOE 记录, 并可设置触发 DO 报警出口。

All out-of-limit actions and returns will trigger SOE records, and the triggering of DO alarm outputs can be set.

(5) 定时越限延时时间必须以 1 秒为步长进行设置。

The delay time for timing overrun must be set in steps of 1 second.

3.10 事件记录 (SOE) Event recording (SOE)

装置可顺序记录装置产生的各类事件, 记录这些事件发生的时间、类型、持续时间和典型值, 时间分辨率为 1ms。记录数据停电不丢失, 记录满后, 将从最早事件开始覆盖。所有事件记录可通过显示面板和通信口读取及进行清除。

The device can sequentially record various events generated by the device, including the time, type, duration, and typical values of these events, with a time resolution of 1ms. The recorded data will not be lost during power outages, and when the recording is full, it will overwrite from the earliest event. All event records can be read and cleared through the display panel and communication port.

装置的事件记录包括监测事件、装置日志、装置自检和事件计数, 其中监测事件和装置日志可分别最多保存 1024 条记录。

The event logs of the device include monitoring events, device logs, device self-inspection, and event counts. Among them, the monitoring events and device logs can store up to 1024 records each.

3.10.1 监测事件 Monitoring events

监测事件包括如下内容 The monitoring events include the following:

表 3-13 监测事件记录

Table 3-13 Monitoring Event Record

事件类别 Event category	事件描述 Event description	特征值 Eigenvalue
越限事件 Out-of-limit event	xx(监测对象)越上限 xx (monitoring object) exceeds the upper limit	发生时刻; 动作值 Occurrence time; action value
	xx(监测对象)越下限 xx (monitoring object) has exceeded the lower limit	结束时刻; 返回值; 最大值; 持续时间 End time; return value; maximum/minimum value; duration
暂态事件 Transient event	A/B/C 相电压触发暂升 Temporary rise in A/B/C phase voltage trigger	发生时刻; 动作值 Occurrence time; action value 结束时刻; 返回值; 最大值; 持续时间 End time; return value; maximum/minimum value; duration
	A/B/C 相电压触发暂降 A/B/C phase voltage trigger sag	发生时刻; 动作值 Occurrence time; action value 结束时刻; 返回值; 最大值; 持续时间 End time; return value; maximum/minimum value; duration
	A/B/C 相电压触发短时中断	发生时刻; 动作值

	Short-term interruption triggered by A/B/C phase voltage	Time of occurrence; action value 结束时刻; 返回值; 最大值; 持续时间 End time; return value; maximum/minimum value; duration
快速电压变动 Rapid voltage fluctuation	A/B/C 相电压触发快速电压变动 A/B/C phase voltage triggers rapid voltage fluctuations	发生时刻; 动作值 Occurrence time; action value 结束时刻; 返回值; 最大值; 持续时间 End time; return value; maximum/minimum value; duration
瞬态扰动 transient disturbance	A/B/C 相电压触发瞬变 A/B/C phase voltage trigger transient	发生时刻; 动作值 Time of occurrence; action value 结束时刻; 返回值; 最大值; 持续时间 End time; return value; maximum/minimum value; duration
波形记录事件 Waveform recording event	手动触发波形记录 Manually trigger waveform recording	发生时刻 Occurrence time
扰动记录事件 Disturbance recording event	手动触发扰动记录 Manually trigger disturbance recording	发生时刻 Occurrence time
突变量 Mutation variable	A 相/B 相/C 相电压突变 A-phase/B-phase/C-phase voltage mutation	发生时刻; 动作值 Occurrence time; action value 结束时刻; 返回值; 最大值; 持续时间 End time; return value; maximum/minimum value; duration
	A 相/B 相/C 相电流突变 A-phase/B-phase/C-phase current mutation	发生时刻; 动作值 Occurrence time; action value 结束时刻; 返回值; 最大值; 持续时间 End time; return value; maximum/minimum value; duration

3.10.2 装置日志 Device log

装置日志包含以下记录内容:

The device log contains the following records:

运行维护人员修改装置设定的参数后, 装置将自动记录这一事件, 记录包含操作的内容和时间, 这些记录不能被修改, 掉电不丢失, 与越限事件、暂态事件记录、故障录波等一起作为事故分析的依据。

After the operation and maintenance personnel modify the parameters set by the device, the device will automatically record this event, including the content and time of the operation. These records cannot be modified and will not be lost in case of power failure. Together with off-limit events, transient event records, fault wave records, etc., they serve as the basis for accident analysis.

装置日志包含如下内容:

The device log contains the following content:

- 上下电记录 Power-on/off records
- 修改系统参数 Modify system parameters
- 校时 Time calibration
- 清除操作 Clear operation

- 切换 TOU 费率方案 Switch to TOU (Time-of-Use) rate plan
- 装置自检信息 Device self-check information

3.10.3 事件计数 Event Counting

装置提供事件计数功能。当有相应的新事件产生后，计数器+1，可统计各类事件发生的次数。包括电压暂升、暂降、中断、瞬态、快速电压变动、电压突变、电流突变电能质量事件分别计数及所有监测事件的总计数。

The device provides an event counting function. When a corresponding new event occurs, the counter increments by 1, allowing for the statistics of the occurrence frequency of various events. This includes separate counting for power quality events such as voltage swells, sags, interruptions, transients, rapid voltage variations, voltage jumps, and current jumps, as well as the total count of all monitored events.

事件计数最大可记录 次，计数累计到最大值后，再次产生事件则翻转为 0，重新开始计数。

The maximum number of events that can be recorded is 2^{32} times. When the count reaches the maximum, any subsequent events will be reset to 0 and the count will start again.

各事件计数器可通过面板和通信方式分别进行清零。

Each event counter can be reset through the panel and communication methods respectively.

表 3-14 事件计数

Table 3-14 Event Count

序号 Serial number	事件计数类别 Event counting category
1	电压暂升 voltage swell
2	电压暂降 voltage sag
3	电压中断 voltage interruption
4	电压瞬态 Voltage transient
5	快速电压变动 Rapid voltage fluctuation
6	电压突变 voltage mutation
7	电流突变 Current surge
8	事件总数 Total number of events

3.11 数据记录功能 Data recording function

3.11.1 最值功能 Extreme value function

装置可记录实时测量值的最值，这包括最大值/最小值的数据与发生时间。

The device can record the extreme values of real-time measurements, including the data of maximum/minimum values and the time of occurrence.

记录下列量的最值 Record the maximum and minimum values of the following quantities:

- 三相电流、平均电流
- Three-phase current, average current
- 三相相电压及平均相电压
- Three-phase phase voltage and average phase voltage
- 三相线电压及平均线电压
- Three-phase line voltage and average line voltage
- 三相有功功率/三相无功功率/三相视在功率
- Three-phase active power/three-phase reactive power/three-phase apparent power

3.11.2 电能记录功能 Electric energy recording function

装置具有电能记录功能，提供总电能相关参数的电能记录。装置根据记录周期提供 2 种电能记录，第一种记录（整点冻结）记录电能实时值，第二种以日为周期（日冻结）记录电能实时值。相关电能参数包括：有功总电能、正向有功总电能、反向有功总电能、无功总电能、正向无功总电能，反向无功总电能。

The device is equipped with an electric energy recording function, providing electric energy records of total electric energy-related parameters. The device offers two types of electric energy records based on the recording period: the first type (hourly freezing) records the real-time value of electric energy, while the second type records the real-time value of electric energy on a daily basis (daily freezing). The relevant electric energy parameters include: total active electric energy, total forward active electric energy, total reverse active electric energy, total reactive electric energy, total forward reactive electric energy, and total reverse reactive electric energy.

两种记录电能数据的记录周期可设置，其中第 1 种可存储 254 条记录，第 2 种可存储 90 条记录。每条记录带日期和时间标志存入非易失性存储器，掉电不丢失。采用循环存储方式存储，当记录存满后覆盖最早存储的数据。电能记录数据可清零。相关参数设置有：

The recording periods for two types of electric energy data can be set. The first type can store 254 records, while the second type can store 90 records. Each record is stored in non-volatile memory with date and time stamps, ensuring that it is retained even in the event of a power loss. A circular storage method is employed, meaning that when the records are full, the oldest data is overwritten. The electric energy recording data can be reset to zero. The relevant parameter settings are as follows:

整点冻结周期：15、30、60min 可选（默认为 60min）。

Whole-point freezing cycle: selectable from 15, 30, and 60 minutes (default is 60 minutes).

日冻结周期：可设置每日内任意时间（默认为 00 时 00 分）。

Daily freeze cycle: Any time within the day can be set (default is 00:00).

以上参数可通过上位机进行设置。

The above parameters can be set through the host computer.

3.11.3 PQDIF

装置具有 16GB 内存容量，普通数据以标准的 PQDIF 格式进行存储，录波数据以 COMTRADE 的格式存储，在无通信条件的情况下，可保持半年左右的全部数据。PQDIF 格式存储数据内容如下：

The device boasts a 16GB memory capacity. It stores regular data in the standard PQDIF format and records data in the COMTRADE format. In the absence of communication, it can retain all data for approximately half a year. The data stored in the PQDIF format includes the following:

表 3-15 PQDIF 存储的数据内容

Table 3-15 Data Content Stored in PQDIF

参数 Parameter	说明 Instructions	相序 Phase sequence	周期 Period
频率 Frequency	频率 Frequency		3 秒 seconds
电压有效值 RMS voltage	相电压 Phase voltage	A、B、C	150 周波 150 cycles
	线电压 Line voltage	AB,BC,CA	
电流有效值 RMS current	电流 Current	A、B、C	
电压偏差 Voltage deviation	相电压偏差 Phase voltage deviation	A、B、C	
	线电压偏差 Line voltage deviation	AB、BC、CA	
基波有效值 Fundamental effective value	电压、电流 Voltage, current	A、B、C	
不平衡度 Unbalance degree	电压、电流 Voltage, current	负、零序 Negative and zero	

		sequence	
序分量 Order component	电压、电流 Voltage, current	正、负、零序 Positive, negative, and zero sequence	
谐波电压 Harmonic voltage	总畸变率、总奇次谐波畸变率、总偶次谐波畸变率、2-25 次谐波电压含有率 Total distortion rate, total odd harmonic distortion rate, total even harmonic distortion rate 2 nd to 25 th harmonic voltage content ratio	A、B、C	
谐波电流 harmonic current	总畸变率、总奇次谐波畸变率、总偶次谐波畸变率、2-25 次谐波电流含有率 Total distortion rate, total odd harmonic distortion rate, total even harmonic distortion rate 2 nd to 25 th harmonic current content ratio	A、B、C	
间谐波电压 Interharmonic voltage	总畸变率、1-25 次间谐波电压含有率 Total distortion rate, 1-25th harmonic voltage content rate	A、B、C	
间谐波电流 Interharmonic current	总畸变率、1-25 次间谐波电流含有率 Total distortion rate, 1 st -25 th harmonic current content rate	A、B、C	
总功率 Total power	P/Q/S/PF	A、B、C、总 A, B, C, Total	
基波功率 Fundamental power	P/Q/S/DF	A、B、C、总 A, B, C, Total	
总谐波功率 Total harmonic power	THP/ THQ/ THS	A、B、C、总 A, B, C, Total	
闪变 Flicker	Pst	A、B、C	10 分钟 minutes
	Plt	A、B、C	2 小时 hours
事件 Event	监测事件 Monitor events		N/A
	波形事件（波形记录、扰动记录） Waveform event (waveform record, disturbance record)		

3.12 波形记录功能 Waveform recording function

3.12.1 波形记录 Waveform recording

装置具有波形记录功能，可由暂态扰动、瞬态扰动、快速电压变动、电压/电流突变、通信条件触发，以 COMTRADE 格式以及 PQDIF 格式存储，掉电不丢失。

The device features waveform recording capabilities, which can be triggered by transient disturbances, rapid voltage fluctuations, sudden voltage/current changes, and communication conditions. The recorded data is stored in both COMTRADE and PQDIF formats and remains intact even in the event of a power loss.

装置可存储 128 条录波数据，循环存储，录波存满后，新的录波数据覆盖最老的数据。录波数据带日期和时间标志存入装置文件系统中，通过监控计算机读取和显示录波图形。

The device can store 128 pieces of oscillograph data, with cyclic storage. When the oscillograph is full, new oscillograph data will overwrite the oldest data. The oscillograph data, marked with date and time, is stored in the device's file system, and the oscillograph graphics can be read and displayed through a monitoring computer.

波形记录可分为 3 个阶段，记录包括事件触发前、事件持续时间及事件结束后三个时段的录波。各段录波记录如下图所示：

Waveform recording can be divided into three stages, encompassing the recording of waveforms during three time periods: before the

event trigger, during the event duration, and after the event ends. The waveform recordings for each period are illustrated in the figure below:



图 3-5 波形记录分段

Figure 3-5 Waveform Record Segmentation

波形记录录波格式及录波触发前周波数可设置，设置范围见下表：

The waveform recording format and the number of cycles before triggering the recording can be set. The setting range is shown in the table below:

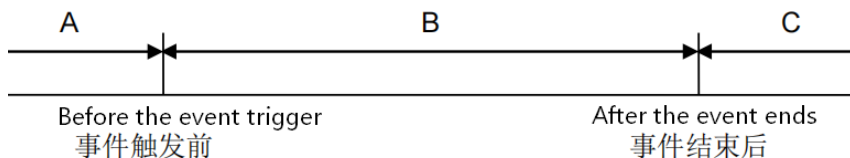
表 3-16 波形记录参数

Table 3-16 Waveform recording parameters

采样率 sampling rate	记录总周波数 (A+B+C) Record the total number of cycles (A+B+C)	触发前周波数设置范围 (A) Triggering pre-cycle number setting range (A)	结束后周波数设置范围 (C) Set range of post-completion cycle number (C)
1024 点/周波 1024 points/cycle	10 周波 10 cycles	2~4 周波可设置 2~4 cycles can be set	2~4 周波可设置 2~4 cycles can be set
512 点/周波 512 points/cycle	20 周波 20 cycles	2~4 周波可设置 The wave frequency can be set between 2 and 4 cycles	2~4 周波可设置 2~4 cycles can be set
256 点/周波 256 points/cycle	40 周波 40 cycles	2~4 周波可设置 2~4 cycles can be set	2~4 周波可设置 2~4 cycles can be set
128 点/周波 128 points/cycle	80 周波 80 cycles	2~4 周波可设置 The frequency can be set between 2 and 4 cycles	2~4 周波可设置 2~4 cycles can be set

注 Note:

波形记录时间根据事件持续时间的长短自动变化：

The waveform recording time automatically adjusts based on the duration of the event:

1) 当“事件的持续时间”小于或等于 B 段可记录的最长周波数，录波的总长度为“触发前周波+事件持续期间周波+结束后周波”；

When the "duration of the event" is less than or equal to the maximum number of cycles that can be recorded in Segment B, the total length of the recorded waveform is "the cycles before triggering + the cycles during the event + the cycles after ending";

2) 当“事件的持续时间”大于 B 段可记录的最长周波数，录波的总长度为最长记录总周波数；

When the "duration of the event" exceeds the maximum number of cycles that can be recorded in Segment B, the total length of the recorded waveform shall be the total number of cycles recorded;

3) 手动触发录波，按记录最大周波数的长度进行录波。

Trigger the wave recording manually, and record the wave based on the length of the maximum number of cycles recorded.

3.12.2 扰动记录 Perturbation record

装置提供扰动记录功能，可记录至少包含一个完整的故障过程，把故障事件分 6 个阶段，记录包括故障起始前后、故障持续过程及故障结束时各个时段的录波。各段录波记录如下图所示

The device provides a disturbance recording function, capable of recording at least one complete fault process. It divides the fault event

into six stages and records the waveforms during various time periods before and after the fault initiation, during the fault duration, and at the end of the fault. The waveform records for each stage are shown in the figure below



图 3-6 暂态录波分段

Figure 3-6 Transient Waveform Recording Segmentation

事件发生后到事件结束后各时段记录的数据说明如下：

The data recorded during various time periods before, during, and after the event are described as follows:

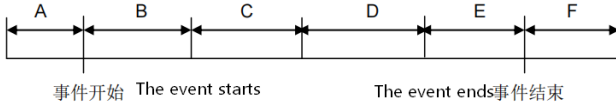
表 3-17 扰动记录事件时段

Table 3-17 Disturbance Recording Event Time Period

事件时段 Event time period	记录说明 Record description	记录时间 Record time	采样率 Sampling rate
A 时段 Time period A	记录系统事件开始前的波形数据 Record the waveform data before the system event starts	5~10 个周波 5~10 cycles	512 点/周波 512 points/cycle
B 时段 Time slot B	记录系统事件开始后初期的波形数据 Record the waveform data in the initial stage after the system event starts	25~30 个周波 25~30 cycles	512 点/周波 512 points/cycle
C 时段 Time slot C	记录系统事件开始后的原始波形数据 Record the raw waveform data since the start of the system event	0~150 个周波 0~150 cycles	16 点/周波 16 points/cycle
D 时段 Time period D	记录系统事件持续期的周波峰值数据 Record the peak value data of the system event duration in cycles	0~18000 个周波 0~18000 cycles	1 点/周波 1 point/cycle
E 时段 Time slot E	记录系统所有事件结束前的波形数据 Record the waveform data before the end of all events in the system	2 个周波 2 cycles	512 点/周波 512 points/cycle
F 时段 Time period F	记录系统所有事件结束后的波形数据 Record the waveform data after all events in the system have ended	13 个周波 13 cycles	512 点/周波 512 points/cycle

注 Note:

C、D 时段记录时间根据事件持续时间的长短自动变化：

The recording time for time slots C and D varies automatically based on the duration of the event:

1) 如果 C 段的持续时间小于 150 周波，则 D 段为 0；

If the duration of Segment C is less than 150 cycles, then Segment D is 0;

2) 如果 C 段记满 150 周波，则开始记录 D 段；

If Section C is recorded for 150 cycles, start recording Section D;

3) 当 D 段记满 18000 周波时，则不再记录 D 段数据；持续时间超过 10min 后，继续记录 E、F 段数据。

When the D segment reaches 18,000 cycles, data recording for the D segment will cease; after a duration exceeding 10 minutes, data recording for the E and F segments will continue.

4) 手动触发扰动记录，按 6 个时段全部记满的长度进行记录。

Manually trigger the disturbance recording, and record the length of all six time periods.

扰动记录数据记录 Ua/Ub/Uc, Ia/Ib/Ic 的波形。

Record the waveforms of disturbance data Ua/Ub/Uc, Ia/Ib/Ic.

- 可由暂态扰动、瞬态扰动、快速电压变动、电压/电流突变;
- It can be caused by transient disturbance, instantaneous disturbance, rapid voltage fluctuation, and voltage/current mutation;
- 提供通信触发扰动记录的功能;
- Provide the function of recording communication trigger disturbances;
- 触发前周波数可设定: 5~10 周波;
- The trigger pre-cycle count can be set between 5 and 10 cycles;
- 设置方式: 可通过装置面板或通信由上位机软件进行设定。
- Setting method: It can be set through the device panel or via communication with the host computer software.

系统内部最多保存 128 条扰动记录数据, 当记录满再产生新的扰动记录事件时, 最新的扰动记录数据覆盖最老的数据, 扰动记录文件采用类 COMTRADE 故障录波方式存储, 掉电不丢失。

The system can store up to 128 pieces of disturbance record data internally. When the records are full and a new disturbance record event occurs, the latest disturbance record data will overwrite the oldest data. The disturbance record file is stored in a COMTRADE-like fault recording format, ensuring that it is not lost in the event of a power failure.

3.12.3 定时录波 Timed wave recording

装置具有定时录波功能, 可根据设定的时间间隔和记录条数, 按照波形记录的格式进行波形数据采集。用户可自行选择投入、退此功能, 默认不投入使用。

The device features a scheduled wave recording function, which enables waveform data acquisition in accordance with the preset time intervals and the number of records, following the waveform recording format. Users have the option to enable or disable this function, and it is disabled by default.

设置好定时录波起始时间及录波间隔, 从设置的时间开始, 装置每隔一定时间进行产生一条波形记录。每次触发定时录波, 装置会报“定时触发波形记录”事件。

Set the starting time and interval for scheduled waveform recording. From the set time, the device will generate a waveform record at regular intervals. Each time the scheduled waveform recording is triggered, the device will report an "Scheduled Triggered Waveform Record" event.

当已触发的定时录波条数达到设置的记录条数时, 定时录波停止, 不再定时触发波形记录。

When the number of triggered scheduled waveform recordings reaches the set recording limit, the scheduled waveform recording will stop, and no more waveform records will be triggered at regular intervals.

定时录波相关的参数设置包括:

The parameter settings related to scheduled wave recording include:

- 投退: 投入/退出, 默认退出;
- Join/Leave: Join/Leave, default is Leave;
- 启动时间: XX 年 XX 月 XX 日, 设置启动日期时间;
- Start time: XX year XX month XX day, set the start date and time;
- 录波间隔: 10~1440 分钟, 可设置, 默认 60 分钟;
- Waveform recording interval: 10~1440 minutes, configurable, default 60 minutes;
- 录波条数: 1~10000 条, 可设置, 默认 1 条;
- Number of recorded waveforms: 1~10000, configurable, default is 1;

- 设置方式：通过通信由上位机软件进行设置。
- Setting method: Settings are made through communication by the host computer software.

3.12.4 有效值记录 Effective value record

装置能提供满足如下要求的有效值记录功能：

The device is capable of providing an effective value recording function that meets the following requirements:

- 可由暂态扰动、瞬态扰动、电压快速变动、电压/电流突变、通信条件触发；
- It can be triggered by transient disturbance, instantaneous disturbance, rapid voltage variation, voltage/current mutation, and communication conditions;
- 提供通信触发有效值记录的功能；
- Provide the function of recording effective values triggered by communication;
- 每条记录 7200 点；
- Each record costs 7200 points;
- 触发前点数可设定：100~500 点；
- The trigger point can be set between 100 and 500 points;
- 实时量记录通道数量：1~8，默认为 8 (Ua、Ub、Uc、Ia、Ib、Ic、Freq.、Freq. Dev.) ；
- Number of real-time quantity recording channels: 1~8, default is 8 (Ua, Ub, Uc, Ia, Ib, Ic, Freq., Freq. Dev.);

采样间隔：0.5 周波~60 周波；

- Sampling interval: 0.5 Hz to 60 Hz;
- 可通过通信由上位机软件进行设定。
- It can be set through communication by the host computer software.

表 3-18 实时量记录对象

Table 3-18 Real-time quantity recording objects

序号 NO.	记录对象 Record object	备注 Remark
1	相电压 (Ua、Ub、Uc) Phase voltage (Ua, Ub, Uc)	最小周期为半周波 The minimum period is half a cycle
2	线电压 (Uab、Ubc、Uca) Line voltage (Uab, Ubc, Uca)	
3	电流 (Ia、Ib、Ic、I4) Current (Ia, Ib, Ic, I4)	
4	频率 (Freq.)、频率偏差 (Freq. Dev.) Frequency (Freq.), Frequency Deviation (Freq. Dev.)	最小周期 1 周波，如果选择了此类通道，采用间隔设置为 0.5 周波，则每 2 次的采样值是一样的 The minimum cycle is 1 cycle. If such a channel is selected and the interval is set to 0.5 cycles, the sampled values will be the same every 2 times
5	三相有功功率 (Pa、Pb、Pc) Three-phase active power (Pa, Pb, Pc)	
6	三相无功功率 (Qa、Qb、Qc) Three-phase reactive power (Qa, Qb, Qc)	
7	三相视在功率 (Sa、Sb、Sc) Three-phase apparent power (Sa, Sb, Sc)	
8	三相总功率因数 (PFa、PFb、PFc) Three-phase total power factor (PFa, PFb, PFC)	

装置内部最多保存 128 条有效值记录数据，当超过时，用最新的高速记录数据覆盖最老的数据，采用类 COMTRADE 故障录波方式存储有效值记录文件，掉电不丢失。

The device can store up to 128 pieces of valid value record data internally. When the limit is exceeded, the oldest data is overwritten with the latest high-speed record data. The valid value record files are stored in a COMTRADE-like fault recording manner, ensuring that they are not lost in the event of a power failure.

3.13 ITIC /SEMI F47 曲线 ITIC /SEMI F47 curve

ITIC 和 SEMI F47 曲线规定了设备必须具备的承受供电电源电压扰动能力，其意义是电力设备对电压干扰耐受能力、评估供电系统电压扰动水平的基准。

The ITIC and SEMI F47 curves specify the required capability of equipment to withstand voltage disturbances in the power supply. Their significance lies in serving as benchmarks for evaluating the tolerance of power equipment to voltage interference and assessing the level of voltage disturbances in power supply systems.

装置显示 ITIC 曲线界面的横轴为电压暂态事件持续时间，纵轴为电压的百分比（相对于标称电压），上方曲线代表设备对电压暂升的耐受力，下方曲线表示设备对电压骤降的耐受力，曲线中间区域表示正常运行范围。如下图，该界面展示单次暂态事件幅值-持续时间的分布。

The device displays the ITIC curve interface, where the horizontal axis represents the duration of voltage transient events and the vertical axis represents the percentage of voltage (relative to the nominal voltage). The upper curve represents the equipment's resistance to voltage swells, while the lower curve represents its resistance to voltage dips. The middle area of the curve indicates the normal operating range. As shown in the figure below, this interface displays the distribution of amplitude-duration for a single transient event.



图 3-7 ITIC 电压容限曲线

Figure 3-7 ITIC Voltage Tolerance Curve

装置显示 SEMI F47 曲线界面的横轴为电压暂态事件持续时间，纵轴为电压的百分比（相对于标称电压）。规范制定了设备对电压暂降的耐受时间，红色实线上方区域代表设备须保证此干扰下可正常持续运行。设备在 0%标称值是持续运行 0.02s，50%标称值是持续运行 0.2s，70%标称值时持续 0.5s，80%时持续 1s，90%标称值时持续 10s。如下图，该界面展示单次暂态事件幅值-持续时间的分布。

The SEMI F47 curve interface displayed on the device has the horizontal axis representing the duration of voltage transient events and the vertical axis indicating the percentage of voltage (relative to the nominal voltage). The specifications define the tolerance time of the equipment to voltage dips, and the area above the red solid line represents the condition under which the equipment must ensure normal continuous operation. The equipment can operate continuously for 0.02s at 0% of the nominal value, 0.2s at 50% of the nominal value, 0.5s at 70% of the nominal value, 1s at 80% of the nominal value, and 10s at 90% of the nominal value. As shown in the figure below, this interface displays the distribution of amplitude-duration for a single transient event.

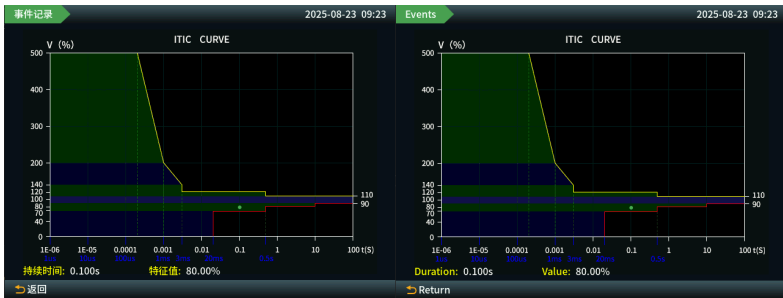

图 3-8 SEMI F47 曲线

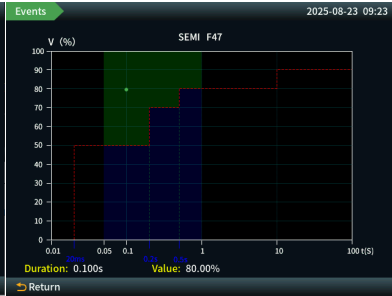

Figure 3-8 SEMI F47 curve

3.14 输入输出功能 Input and output functions

3.14.1 开关量输入 Switching value input

装置提供 6 个光耦开关量输入，并提供 12V 内置激励电源，包括 6 路(DI)。

The device provides six optocoupler switch inputs and a built-in 12V excitation power supply, including six digital input (DI) channels.

DI 功能 DI function

用于检测外部无源接点的状态。

Used to detect the status of external passive contacts.

通过液晶显示或通信可以观测到开关量输入的实时状态。

The real-time status of switch input can be observed through liquid crystal display or communication.

3.14.2 开关量输出 Switching value output

装置提供 4 路继电器输出 (DO), 可用于告警输出。

The device provides 4 relay outputs (DO), which can be used for alarm output.

装置所提供的继电器有以下几种控制方式：遥控、定值越限、暂态扰动、电压瞬态扰动、快速电压变动触发。

The relay provided by the device has the following control modes: remote control, fixed value overrun, transient disturbance, voltage transient disturbance, and fast voltage change trigger.

DO 输出模式有 2 种：电平式和脉冲式，可通过上位机设置，脉宽设置范围在 0.1~300.0 秒，以 0.1 秒为步长。

- There are two types of DO output modes: level type and pulse type, which can be set through the host computer. The pulse width setting range is 0.1~300.0 seconds, with a step size of 0.1 seconds.

定值越限动作可触发继电器动作，当越限返回时，继电器返回。

- The action of exceeding the set value limit can trigger the relay action. When the limit is returned, the relay returns.

暂态扰动/瞬态扰动/快速电压变动触发继电器动作。

- Transient disturbance/instantaneous disturbance/rapid voltage fluctuation triggers relay action.

3.14.3 电能脉冲输出 Electric energy pulse output

装置提供 2 个电能脉冲输出 EC1~EC2，仅可用于接点脉冲输出。

The device provides two electrical energy pulse outputs, EC1 and EC2, which can only be used for contact pulse output.

3.14.4 秒脉冲输出 Second pulse output

装置提供 1 个秒脉冲输出，仅可用于接点脉冲输出。

The device provides one second pulse output, which can only be used for contact pulse output.

3.15 通信功能 Communication function

装置提供 2 个以太网接口，支持 Modbus TCP、IEC61850 协议、GOOSE 协议；2 个 RS485 接口，支持 Modbus RTU 协议。

The device provides two Ethernet interfaces, supporting Modbus TCP, IEC61850 protocol, and GOOSE protocol; and two RS485 interfaces, supporting Modbus RTU protocol.

装置可以接入各种电力监控网络中，上位机软件通过以上任一种通信口，能够读取并显示所有被测量参数和状态信息、数据记录等，同时对装置进行整定，并可接收上位机遥控指令。

The device can be integrated into various power monitoring networks. The host computer software can read and display all measured parameters, status information, data records, etc. through any of the above communication ports. Additionally, it can configure the device and receive remote control instructions from the host computer.

3.15.1 RS-485 通信 RS-485 communication

RS-485 通信接口支持 MODBUS 通信规约，波特率 4800 bps, 9600 bps, 19200bps, 38400 bps, 115200bps 可选，奇偶校验位可以进行设置。

The RS-485 communication interface supports the MODBUS communication protocol, with baud rates of 4800 bps, 9600 bps, 19200 bps, 38400 bps, and 115200 bps being selectable, and the parity bit can be set.

3.15.2 以太网通信 Ethernet communication

以太网接口采用标准的 RJ45 接口，通信速率 10M/100M 自适应。支持 Modbus TCP, IEC 61850 通信规约。

The Ethernet interface adopts a standard RJ45 connector, with a communication rate that is adaptive to both 10M and 100M. It supports Modbus TCP and IEC 61850 communication protocols.

3.16 时钟功能 Clock function

3.16.1 时钟 Clock

装置采用带有温度补偿功能的内置硬件时钟电路，在-25~+60℃的温度范围内：时钟准确度应 $\leq \pm 1s/d$ ；在参比温度（23℃）下，时钟准确度 $\leq \pm 0.5s/d$ 。时钟具有自动计算日历、计时、闰年自动转换功能。

The device incorporates a built-in hardware clock circuit with temperature compensation function; within the temperature range of -25 to +60℃, the clock accuracy should be $\leq \pm 1s/d$; at the reference temperature (23℃), the clock accuracy is $\leq \pm 0.5s/d$. The clock features automatic calendar calculation, timing, and leap year automatic conversion functions.

3.16.2 对时功能 Time Synchronization Function

装置可设置选择以下时钟源：内部时钟源（RTC）、PPS 对时、IRIG-B 对时信号、SNTP 网络时钟源。通过 Modbus 规约进行软件对时，不受装置时钟源设置影响。

The device can be set to select the following clock sources: internal clock source (RTC), PPS timing, IRIG-B timing signal, and SNTP network clock source. Software timing is performed through the Modbus protocol and is not affected by the device clock source settings.

当采用 IRIG-B 对时、PPS 差分对时或 SNTP 网络对时的情况下，需将装置时钟源设置到对应值。若运行环境没有时钟同步设备，则需将时钟源设置为 RTC（装置内部时钟），以保证系统走时的精确性。当通过 IRIG-B 对时或 PPS 差分对时后，时钟源会自动切换为 RTC。

When using IRIG-B timing, PPS differential timing, or SNTP network timing, the device clock source needs to be set to the corresponding value. If there is no clock synchronization device in the operating environment, the clock source should be set to RTC (the device's internal clock) to ensure the accuracy of the system's timekeeping. After timing via IRIG-B or PPS differential, the clock source will automatically switch to RTC.

IRIG-B 码对时接口复用 RS485-1 接口，在使用 IRIG-B 码对时时，将时钟源设置为 IRIG-B。

The IRIG-B code timing interface multiplexes the RS485-1 interface. Before using the IRIG-B code for timing, set the clock source to IRIG-B.

对时接口如下 The timing interface is as follows:

表 3-19 IRIG-B 对时接口

Table 3-19 IRIG-B timing interface

对时方式 Time synchronization		对应接线端子 Corresponding wiring terminal	需要设置的参数 Parameters that need to be set
IRIG-B 码对时 IRIG-B code timing	P+	RS485-1A	“时钟源”设置为 IRIG-B “Clock source” is set to IRIG-B
	P-	RS485-1B	

(1) PPS 对时 PPS time synchronization

(2) PPS 脉冲对时方式支持秒脉冲和分脉冲对时，装置只支持外部秒脉冲信号。由于 PPS 脉冲同步只包含整分/整秒的边沿信号、不能提供具体时/分/秒的值，实际使用过程中应与软件对时配合使用，以达到全站精确时钟同步、误差在±1ms 以内。

The PPS (Pulse Per Second) pulse timing method supports both second pulse and minute pulse timing, and the device only supports external second pulse signals. Since PPS pulse synchronization only includes edge signals of whole minutes/seconds and cannot provide specific values of hours/minutes/seconds, it should be used in conjunction with software timing in practical applications to achieve precise clock synchronization across the entire station, with an error within ±1ms.

使用 PPS 对时，需要先设置校时源参数为 PPS 模式。

When using PPS for time synchronization, it is necessary to first set the time source parameter to PPS mode.

(2) IRIG-B 对时 IRIG-B time synchronization

IRIG-B 对时方式能从输入信号中解析出精确的年/月/日/时/分/秒信息，无需其他对时手段配合即可达到微秒级的授时精度。因实际接入的 IRIG-B 信号可能是带有时区信息的非标准信号，系统提供一个 IRIG-B 校正参数，用于修正输入 IRIG-B 的时钟。

The IRIG-B time synchronization method can accurately parse the year/month/day/hour/minute/second information from the input signal, achieving microsecond-level timing accuracy without the need for other timing methods. Since the actual received IRIG-B signal may be a non-standard signal with time zone information, the system provides an IRIG-B correction parameter to adjust the clock of the input IRIG-B.

使用 IRIG-B 对时，需要先设置校时源参数为 IRIG-B 模式。

When using IRIG-B for time synchronization, it is necessary to first set the time source parameter to IRIG-B mode.

(3) SNTP 对时 SNTP time synchronization

SNTP 网络对时是装置自动从网络时间服务器获取高精度时间，其中 SNTP 广播对时还要求装置与授时源的时差在 5 分钟以内（单播对时无此限制）。

SNTP network time synchronization involves the device automatically obtaining high-precision time from a network time server. For SNTP broadcast time synchronization, it is also required that the time difference between the device and the timing source be within 5 minutes (unicast time synchronization does not have this limitation).

装置支持 SNTP 单播和广播两种对时方式

The device supports both SNTP unicast and broadcast as time synchronization methods

SNTP 单播对时：装置会按设定的时间间隔，主动连接服务器进行对时操作。

➤ SNTP unicast time synchronization: The device will proactively connect to the server for time synchronization at preset intervals.

实现 SNTP 单播对时需要设置的参数有：

The parameters that need to be set to implement SNTP unicast time synchronization are:

- 时钟源：SNTP;

- Clock source: SNTP;
 - SNTP 校时间隔: 10 分钟~1440 分钟 (24 小时) ;
 - SNTP time interval: 10 minutes to 1440 minutes (24 hours);
 - SNTP 服务器地址: 网络时间服务器的 IP 地址;
 - SNTP server address: IP address of the network time server;
- SNTP 广播对时 SNTP broadcast time synchronization

实现 SNTP 广播对时需要设置的参数有:

The parameters that need to be set to implement SNTP broadcast time synchronization are:

- 时钟源: SNTP; Clock source: SNTP;

(4) SNTP 广播标志: 0: 关闭 SNTP 广播对时; 1: 打开 SNTP 广播对时

SNTP broadcast flag: 0: Disable SNTP broadcast time synchronization; 1: Enable SNTP broadcast time synchronization

Modbus 通信对时 Modbus communication time synchronization

(5) Modbus 通信对时是上位机通过 Modbus 协议对装置进行对时。

Modbus communication time synchronization involves the host computer synchronizing the device through the Modbus protocol.

3.17 USB 功能 USB function

3.17.1 USB 升级程序 USB upgrade program

本设备配备一个 USB 接口, 支持通过 U 盘进行程序升级。可以将最新文件存入 U 盘根目录下, 插入设备后即可在系统设置中一键完成升级。

This device is equipped with a USB interface, supporting program upgrades via a USB flash drive. You can store the latest files in the root directory of the USB flash drive, and after inserting it into the device, you can complete the upgrade with one click in the system settings.

注 Note:

1) 请使用 FAT32 或 exFAT 格式的 U 盘, 不支持 NTFS 格式。

Please use a USB flash drive formatted with FAT32 or exFAT. NTFS format is not supported.

2) 升级过程中, 设备屏幕会显示进度条, 请保持设备供电, 切勿断电。

During the upgrade process, a progress bar will be displayed on the device screen. Please keep the device powered on and do not disconnect the power.

3) 升级完成后设备会自动重启, 重启后请核对新程序版本号以确认升级成功。

After the upgrade is completed, the device will automatically restart. Please verify the new program version number after the restart to confirm that the upgrade has been successful.

4) 建议在系统空闲、无重要任务时执行升级操作。

It is recommended to perform the upgrade operation when the system is idle and there are no important tasks running.

第四章 使用与操作 Chapter 4: Usage and Operation

本装置采用 TFT 彩色液晶屏，分辨率为 640×480，色彩模式为 RGB。人机界面实现了菜单化，操作方便简洁。

This device utilizes a TFT color LCD screen with a resolution of 640×480 and an RGB color mode. The user interface is menu-driven, making operation convenient and straightforward.

4.1 键盘定义 Keyboard definition

前面板键盘由 6 个按键组成，分别是“上”、“下”、“左”、“右”、“确认”、“返回”，具体功能如下：

The front panel keyboard consists of six buttons, namely "Up", "Down", "Left", "Right", "Confirm", and "Return". Their specific functions are as follows:

按键 Button	图案 pattern	功能说明 Functional Description
上键 Up key	▲	向上移动光标；设置数据时，数据加一。 Move the cursor up; when setting data, increment the data by one.
下键 Down key	▼	向下移动光标；设置数据时，数据减一。 Move the cursor downwards; when setting data, subtract one from the data.
左键 Left button	◀	向左移动光标；或向左翻页。 Move the cursor to the left; or turn the page to the left.
右键 Right-click	▶	向右移动光标；或向右翻页。 Move the cursor to the right; or turn the page to the right.
确认键 Confirm button	⏎	进入下一级菜单；或确认输入值。 Enter the next level menu; or confirm the input value.
返回键 Back button	↶	返回上一级菜单；或取消输入值。 Return to the previous menu; or cancel the input value.

4.2 脉冲灯定义 Definition of pulse lamp

本装置前面板共有 3 个双色 LED 灯，定义如下：

The front panel of this device features three dual-color LED lights, defined as follows:

运行灯 RUN：装置上电时，红色 LED 点亮，表示正处于初始化阶段。初始化成功后，装置进入正常运行状态，绿色 LED 常亮，红色 LED 熄灭。若初始化失败或运行时出现异常，红色 LED 点亮，绿色 LED 熄灭。

Operation light (RUN): When the device is powered on, the red LED illuminates, indicating that it is in the initialization phase. After successful initialization, the device enters the normal operation state, with the green LED constantly lit and the red LED extinguished. If initialization fails or an exception occurs during operation, the red LED illuminates and the green LED is extinguished.

通信灯：当装置通信运行正常时，绿色 LED 灯常亮，红色灭，反之绿色灯灭，红色灯亮。

Communication light: When the device's communication is functioning normally, the green LED light is constantly on and the red light is off. Conversely, if the communication is abnormal, the green light is off and the red light is on.

告警灯 ERROR：当装置监测到有告警事件时，红色灯亮起，绿色灯灭，反之红色灭，绿色灯亮。

Alarm light ERROR: When the device detects an alarm event, the red light will be on and the green light will be off. Conversely, if the red light is off, the green light will be on.

4.3 菜单说明 Menu description



装置上电，开始初始化界面，完成后进入主菜单页面。主菜单显示 9 个一级菜单，包括“基本测量”、“波形显示”、“电能计量”、“需量统计”、“分时计量”、“电能质量”、“事件记录”、“表计状态”“参数设置”，如上所示。

The device is powered on and initiates the initialization interface. Upon completion, it enters the main menu page. The main menu displays nine primary menus, including "Measure", "Waveform", "Energy", "Demand", "TOU", "P.Q.", "Event", "Status", and "Settings", as shown above.

表 4-1 菜单目录概览

Table 4-1 Overview of Menu Contents

一级菜单 Primary Menu	二级菜单 Sub-menu
基本测量 Measure	矢量图 Phasor
	全波数据 RMS
	基波数据 Fundamental
	最大值 Maximum
	最小值 Minimum
波形显示 Wavefor	电压波形 Voltage waveform
	电流波形 Current waveform
电能质量 P.Q.	谐波 Harmonics
	间谐波 Interharm.
	偏差 Deviation
	不平衡度 Unbalance
电能计量 Energy	闪变 Flicker
	全波电能 RMS Energy
	基波电能 Fund.Energy
	谐波电能 Harm.Energy
需量统计 Demand	实时需量 Real-Time Dem.
	最大需量 Max. Dem.
分时计量 TOU	费率电能 TOU Energy
	费率需量 TOU Demand
事件记录 Events	监测事件 SOE Log
	装置日志 Dev. Log
	事件计数 PQ Counters
表计状态 Status	实时告警 Alarms

	I/O 状态 Status
参数设置 Settings	基本参数 Basic
	通信参数 Comm.
	电能质量参数 PQ
	波形记录 wave Record
	时间设置 Clock
	装置操作 Maintenance
	装置信息 Device info
	监测点信息 Site info.

4.3.1 基本测量 Basic measurement

“基本测量”菜单包含 5 个子菜单：矢量图、全波数据、基波数据、最大值、最小值，通过“◀”、“▶”方向键可切换子菜单页面。

The "Measure" menu includes five submenus: Phasor, RMS, Fundamental, Maximum, and Minimum. Submenu pages can be switched using the "◀" and "▶" arrow keys.

(1) 矢量图 Vector graphic

“矢量图”界面显示三相电压、电流矢量图，以及三相电压、电流的幅值和相角。如下图所示：

The "Phasor" interface displays the vector diagrams of three-phase voltage and current, as well as the amplitude and phase angle of the three-phase voltage and current. As shown in the figure below:



全波数据 Full-wave data

“全波数据”界面显示实时电压、电流、有功、无功、功率因数、频率、相角等基本测量量。如下图所示：

The "RMS" interface displays basic measurements such as real-time voltage, current, active power, reactive power, power factor, frequency, and phase angle, as shown in the figure below:



(2) 基波数据 Fundamental wave data

“基波数据”界面显示基波电压、基波电流、基波有功、基波无功、基波功率因数等基波测量量。如下图所示：

The "Fundamental" interface displays fundamental wave measurements such as fundamental wave voltage, fundamental wave current, fundamental wave active power, fundamental wave reactive power, and fundamental wave power factor, as shown in the figure below:

基本测量		2025-08-23 09:23				Measure				2025-08-23 09:23			
矢量图	全波数据	基波数据		最大值	最小值	Phasor	RMS	Fundamental		Maximum	Minimum		
	A/AB	B/BC	C/CA	Total/Avg			A/AB	B/BC	C/CA	Total/Avg			
相电压	220.000V	220.000V	220.000V	0.000V		Uln	220.000V	220.000V	220.000V	0.000V			
线电压	220.000V	220.000V	0.000V	0.000V		Ull	220.000V	220.000V	0.000V	0.000V			
电流	5.000A	5.000A	5.000A	0.000A		I	250.000kA	250.000kA	250.000kA	0.000A			
电压相位	0.00°	240.00°	120.00°	-		U Angle	0.00°	240.00°	120.00°	-			
电流相位	30.00°	270.00°	150.00°	-		I Angle	30.00°	270.00°	150.00°	-			
功率因数	0.000	0.000	0.000	0.000		PF	0.000	0.000	0.000	0.000			
有功功率	54.5000MW	0.0000kW	0.0000kW	0.0000kW		P	54.5000MW	0.0000kW	0.0000kW	0.0000kW			
无功功率	0.0000kvar	0.0000kvar	0.0000kvar	0.0000kvar		Q	0.0000kvar	0.0000kvar	0.0000kvar	0.0000kvar			
视在功率	0.0000kVA	0.0000kVA	0.0000kVA	0.0000kVA		S	0.0000kVA	0.0000kVA	0.0000kVA	0.0000kVA			

(3) 最大值 Maximum

“最大值”界面显示三相相电压、线电压、三相电流和功率的最大及发生时间，如下图所示：

The "Maximum" interface displays the maximum values and occurrence times of three-phase phase voltage, line voltage, three-phase current, and power, as shown in the figure below:

基本测量		2025-08-23 09:23				Measure				2025-08-23 09:23			
矢量图	全波数据	基波数据		最大值	最小值	Phasor	RMS	Fundamental	Maximum	Minimum			
	最大值	发生时间	最大值	发生时间		Max. Value	Occur. Time	Max. Value	Occur. Time				
Ua	0.000V	23-01-05 23:00:20	Pa	0.000kW	23-01-05 23:00:20	Ua	0.000V	23-01-05 23:00:20	Pa	0.000kW	23-01-05 23:00:20		
Ub	0.000V	23-01-05 23:00:20	Pb	0.000kW	23-01-05 23:00:20	Ub	0.000V	23-01-05 23:00:20	Pb	0.000kW	23-01-05 23:00:20		
Uc	0.000V	23-01-05 23:00:20	Pc	0.000kW	23-01-05 23:00:20	Uc	0.000V	23-01-05 23:00:20	Pc	0.000kW	23-01-05 23:00:20		
Uab	0.000V	23-01-05 23:00:20	Qa	0.000kvar	23-01-05 23:00:20	Uab	0.000V	23-01-05 23:00:20	Qa	0.000kvar	23-01-05 23:00:20		
Ubc	0.000V	23-01-05 23:00:20	Qb	0.000kvar	23-01-05 23:00:20	Ubc	0.000V	23-01-05 23:00:20	Qb	0.000kvar	23-01-05 23:00:20		
Uca	0.000V	23-01-05 23:00:20	Qc	0.000kvar	23-01-05 23:00:20	Uca	0.000V	23-01-05 23:00:20	Qc	0.000kvar	23-01-05 23:00:20		
Ia	0.000A	23-01-05 23:00:20	Sa	0.000kVA	23-01-05 23:00:20	Ia	0.000A	23-01-05 23:00:20	Sa	0.000kVA	23-01-05 23:00:20		
Ib	0.000A	23-01-05 23:00:20	Sb	0.000kVA	23-01-05 23:00:20	Ib	0.000A	23-01-05 23:00:20	Sb	0.000kVA	23-01-05 23:00:20		
Ic	0.000A	23-01-05 23:00:20	Sc	0.000kVA	23-01-05 23:00:20	Ic	0.000A	23-01-05 23:00:20	Sc	0.000kVA	23-01-05 23:00:20		

(4) 最小值 Minimum

“最小值”界面显示三相相电压、线电压、三相电流和功率的最大及发生时间，如下图所示：

The "Minimum" interface displays the maximum values and occurrence times of three-phase phase voltage, line voltage, three-phase current, and power, as shown in the figure below:

基本测量		2025-08-23 09:23				Measure				2025-08-23 09:23			
矢量图	全波数据	基波数据		最大值	最小值	Phasor	RMS	Fundamental	Maximum	Minimum			
	最小值	发生时间	最小值	发生时间		Min. Value	Occur. Time	Min. Value	Occur. Time				
Ua	0.000V	23-01-05 23:00:20	Pa	0.000kW	23-01-05 23:00:20	Ua	0.000V	23-01-05 23:00:20	Pa	0.000kW	23-01-05 23:00:20		
Ub	0.000V	23-01-05 23:00:20	Pb	0.000kW	23-01-05 23:00:20	Ub	0.000V	23-01-05 23:00:20	Pb	0.000kW	23-01-05 23:00:20		
Uc	0.000V	23-01-05 23:00:20	Pc	0.000kW	23-01-05 23:00:20	Uc	0.000V	23-01-05 23:00:20	Pc	0.000kW	23-01-05 23:00:20		
Uab	0.000V	23-01-05 23:00:20	Qa	0.000kvar	23-01-05 23:00:20	Uab	0.000V	23-01-05 23:00:20	Qa	0.000kvar	23-01-05 23:00:20		
Ubc	0.000V	23-01-05 23:00:20	Qb	0.000kvar	23-01-05 23:00:20	Ubc	0.000V	23-01-05 23:00:20	Qb	0.000kvar	23-01-05 23:00:20		
Uca	0.000V	23-01-05 23:00:20	Qc	0.000kvar	23-01-05 23:00:20	Uca	0.000V	23-01-05 23:00:20	Qc	0.000kvar	23-01-05 23:00:20		
Ia	0.000A	23-01-05 23:00:20	Sa	0.000kVA	23-01-05 23:00:20	Ia	0.000A	23-01-05 23:00:20	Sa	0.000kVA	23-01-05 23:00:20		
Ib	0.000A	23-01-05 23:00:20	Sb	0.000kVA	23-01-05 23:00:20	Ib	0.000A	23-01-05 23:00:20	Sb	0.000kVA	23-01-05 23:00:20		
Ic	0.000A	23-01-05 23:00:20	Sc	0.000kVA	23-01-05 23:00:20	Ic	0.000A	23-01-05 23:00:20	Sc	0.000kVA	23-01-05 23:00:20		

4.3.2 波形显示 Waveform display

“波形显示”菜单包含 2 个子菜单：电压波形、电流波形，通过“◀”、“▶”方向键可切换子菜单页面。点击录波、扰动记录可实现手动录波和手动触发扰动记录。

The "Waveform" menu includes two submenus: Voltage Waveform and Current Waveform. You can switch between submenu pages using the "◀" and "▶" arrow keys. By clicking on "Record Waveform" and "Disturbance Record", you can enable manual waveform recording and manual disturbance triggering.

(1) 电压波形 Voltage waveform

“电压波形”界面显示三相电压的实时波形，通过方向键可以选择任意波形通道，点击暂停/刷新按钮还可以切换波形动态显示或停止。如下图所示

The "Voltage Waveform" interface displays the real-time waveform of three-phase voltage. You can select any waveform channel using the arrow keys, and clicking the pause/refresh button can toggle between dynamic waveform display and stopping it, as shown in the figure below

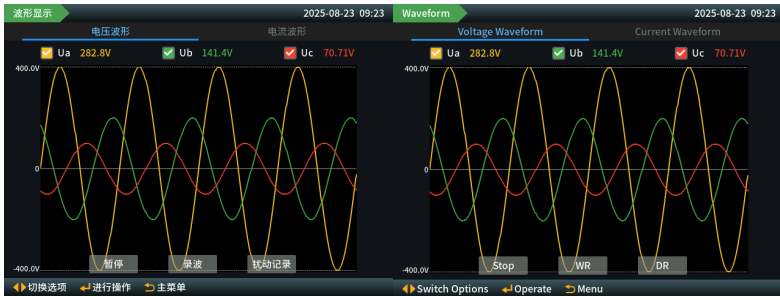

(2) 电流波形 Current waveform

“电流波形”界面显示三相电流的实时波形，通过方向键可以选择任意波形通道，点击暂停/刷新按钮还可以切换波形动态显示或停止。如下图所示：

The "Current Waveform" interface displays the real-time waveform of three-phase current. You can select any waveform channel using the arrow keys, and clicking the pause/refresh button can toggle between dynamic waveform display and stopping it. As shown in the figure below:



4.3.3 电能质量 Power quality

“电能质量”菜单包含 5 个子菜单：谐波、间谐波、偏差、不平衡度、闪变，通过“◀”、“▶”方向键可切换子菜单页面。

The "P.Q." menu includes five submenus: Harmonics, Interharm, Deviation, Unbalance, and Flicker. Submenu pages can be switched using the "◀" and "▶" arrow keys.

(1) 谐波 Harmonic wave

“谐波”界面显示 1~63 次的电压、电流谐波的棒图，总谐波畸变率，总奇次、偶次谐波畸变率，峰值因子和 K 因子，三相总谐波有功/无功/视在功率、总谐波功率因数；电压、电流谐波棒图界面，通过“确认”键可以查看各次谐波的含有率、有效值和相角。

三相谐波功率界面，通过“确认”键可以查看分次谐波功率列表。如下图所示：

The "Harmonics" interface displays bar graphs of voltage and current harmonics from 1st to 63rd order, total harmonic distortion rate, total odd and even harmonic distortion rates, crest factor and K factor, three-phase total harmonic active/reactive/apparent power, and total harmonic power factor. On the voltage and current harmonic bar graph interface, the content rate, effective value, and phase angle of each harmonic order can be viewed by pressing the "Confirm" button. On the three-phase harmonic power interface, the list of sub-harmonic power can be viewed by pressing the "Confirm" button. As shown in the figure below:



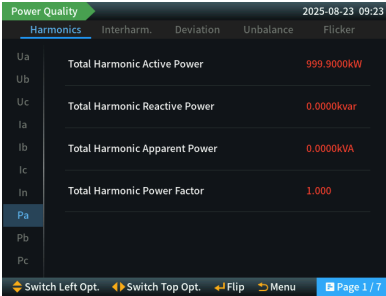

Order	P	Q	S	PF
1	0.0000kW	0.0000kvar	0.0000kVA	0.000
2	0.0000kW	0.0000kvar	0.0000kVA	0.000
3	0.0000kW	0.0000kvar	0.0000kVA	0.000
4	0.0000kW	0.0000kvar	0.0000kVA	0.000
5	0.0000kW	0.0000kvar	0.0000kVA	0.000
6	0.0000kW	0.0000kvar	0.0000kVA	0.000
7	0.0000kW	0.0000kvar	0.0000kVA	0.000
8	0.0000kW	0.0000kvar	0.0000kVA	0.000
9	0.0000kW	0.0000kvar	0.0000kVA	0.000
10	0.0000kW	0.0000kvar	0.0000kVA	0.000
11	0.0000kW	0.0000kvar	0.0000kVA	0.000

(2) 间谐波 Interharmonics

“间谐波”界面显示 0-62 次的电压、电流间谐波的棒图，总间谐波畸变率，总奇次、偶次间谐波畸变率；通过“确认”键可以查看各次间谐波的含有率和有效值。如下图所示：

The "Interharmonics" interface displays a bar graph of voltage and current interharmonics from 0 to 62 times, as well as the total interharmonic distortion rate, and the total odd and even interharmonic distortion rates. By clicking the "Confirm" button, you can view the content rate and effective value of each order of interharmonics. As shown in the figure below:



Order	含有率	有效值
0次	0.00%	0.000V
1次	0.00%	0.000V
2次	0.00%	0.000V
3次	0.00%	0.000V
4次	0.00%	0.000V
5次	0.00%	0.000V
6次	0.00%	0.000V
7次	0.00%	0.000V
8次	0.00%	0.000V
9次	0.00%	0.000V
10次	0.00%	0.000V

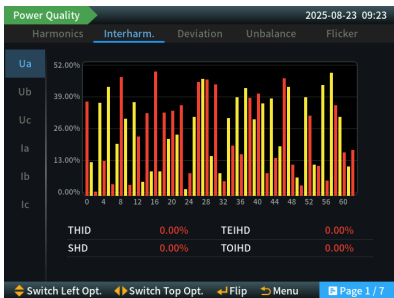

Order	IHR	IHRMS
0	0.00%	0.000V
1	0.00%	0.000V
2	0.00%	0.000V
3	0.00%	0.000V
4	0.00%	0.000V
5	0.00%	0.000V
6	0.00%	0.000V
7	0.00%	0.000V
8	0.00%	0.000V
9	0.00%	0.000V
10	0.00%	0.000V

(3) 偏差 Deviation

“偏差”界面显示相电压和线电压的上/下偏差，以及频率偏差。如下图所示：

The "Deviation" interface displays the upper/lower deviations of phase voltage and line voltage, as well as frequency deviation. As shown in the figure below:



(4) 不平衡 Unbalance degree

“不平衡度”界面显示正序、负序、零序电压和电流值，及负序、零序电压和电流不平衡度。如下图所示：

The "Unbalance" interface displays the positive-sequence, negative-sequence, and zero-sequence voltage and current values, as well as the unbalance degrees of negative-sequence and zero-sequence voltage and current. As shown in the figure below:



(5) 闪变 Flicker

“闪变”界面显示三相电压的短时闪变、长时闪变、电压波动和变动频度。如下图所示：

The "Flicker" interface displays short-term flicker, long-term flicker, voltage fluctuation, and variation frequency of three-phase voltage, as shown in the figure below:



4.3.4 电能计量 Electric energy metering

“电能计量”菜单包含 3 个子菜单：全波电能、基波电能、谐波电能，通过“◀”、“▶”方向键可切换子菜单页面。

The "Energy" menu includes three submenus: RMS Energy, Fund. Energy, and Harm Energy. Submenu pages can be switched using the "◀" and "▶" arrow keys.

(1) 全波电能 Full-wave electric energy

“全波电能”界面显示三相分相全波电能和总全波电能，包括组合有功、正、反向有功、组合无功、四象限无功和正、反向视在。如下图所示：

The "RMS Energy" interface displays three-phase split-phase full-wave electric energy and total full-wave electric energy, including combined active power, forward and reverse active power, combined reactive power, four-quadrant reactive power, and forward and reverse apparent power. As shown in the figure below:

电能计量				Energy			
2025-08-23 09:23				2025-08-23 09:23			
全波电能		基波电能		谐波电能		RMS Energy	
总电能	A相电能	B相电能	C相电能	Total	Phase A	Phase B	Phase C
组合有功	0.000kWh	0.000kWh	0.000kWh	P Comb.	0.000kWh	0.000kWh	0.000kWh
正向有功	0.000kWh	0.000kWh	0.000kWh	P Positive	0.000kWh	0.000kWh	0.000kWh
反向有功	0.000kWh	0.000kWh	0.000kWh	P Negative	0.000kWh	0.000kWh	0.000kWh
组合无功1	0.000kvarh	0.000kvarh	0.000kvarh	Q Comb. 1	0.000kvarh	0.000kvarh	0.000kvarh
组合无功2	0.000kvarh	0.000kvarh	0.000kvarh	Q Comb. 2	0.000kvarh	0.000kvarh	0.000kvarh
一象限无功	0.000kvarh	0.000kvarh	0.000kvarh	Q Quad. 1	0.000kvarh	0.000kvarh	0.000kvarh
二象限无功	0.000kvarh	0.000kvarh	0.000kvarh	Q Quad. 2	0.000kvarh	0.000kvarh	0.000kvarh
三象限无功	0.000kvarh	0.000kvarh	0.000kvarh	Q Quad. 3	0.000kvarh	0.000kvarh	0.000kvarh
四象限无功	0.000kvarh	0.000kvarh	0.000kvarh	Q Quad. 4	0.000kvarh	0.000kvarh	0.000kvarh
正向视在	0.000kVAh	0.000kVAh	0.000kVAh	S Positive	0.000kVAh	0.000kVAh	0.000kVAh
反向视在	0.000kVAh	0.000kVAh	0.000kVAh	S Negative	0.000kVAh	0.000kVAh	0.000kVAh

(2) 基波电能 Fundamental wave electric energy

“基波电能”界面显示三相分相基波电能和总基波电能，包括组合有功、正、反向有功、组合无功、四象限无功和正、反向视在。如下图所示：

The "Fund. Energy" interface displays the three-phase split-phase fundamental electric energy and total fundamental electric energy, including combined active power, forward and reverse active power, combined reactive power, four-quadrant reactive power, and forward and reverse apparent power. As shown in the figure below:

电能计量				Energy			
2023-11-23 09:23				2025-08-23 09:23			
全波电能		基波电能		谐波电能		RMS Energy	
总电能	A相电能	B相电能	C相电能	Total	Phase A	Phase B	Phase C
组合有功	0.000kWh	0.000kWh	0.000kWh	P Comb.	0.000kWh	0.000kWh	0.000kWh
正向有功	0.000kWh	0.000kWh	0.000kWh	P Positive	0.000kWh	0.000kWh	0.000kWh
反向有功	0.000kWh	0.000kWh	0.000kWh	P Negative	0.000kWh	0.000kWh	0.000kWh
组合无功1	0.000kvarh	0.000kvarh	0.000kvarh	Q Comb. 1	0.000kvarh	0.000kvarh	0.000kvarh
组合无功2	0.000kvarh	0.000kvarh	0.000kvarh	Q Comb. 2	0.000kvarh	0.000kvarh	0.000kvarh
一象限无功	0.000kvarh	0.000kvarh	0.000kvarh	Q Quad. 1	0.000kvarh	0.000kvarh	0.000kvarh
二象限无功	0.000kvarh	0.000kvarh	0.000kvarh	Q Quad. 2	0.000kvarh	0.000kvarh	0.000kvarh
三象限无功	0.000kvarh	0.000kvarh	0.000kvarh	Q Quad. 3	0.000kvarh	0.000kvarh	0.000kvarh
四象限无功	0.000kvarh	0.000kvarh	0.000kvarh	Q Quad. 4	0.000kvarh	0.000kvarh	0.000kvarh
正向视在	0.000kVAh	0.000kVAh	0.000kVAh	S Positive	0.000kVAh	0.000kVAh	0.000kVAh
反向视在	0.000kVAh	0.000kVAh	0.000kVAh	S Negative	0.000kVAh	0.000kVAh	0.000kVAh

(3) 谐波电能 Harmonic electric energy

“谐波电能”界面显示三相分相谐波电能和总谐波电能，包括组合有功、正、反向有功、组合无功、四象限无功和正、反向视在，通过“▲”、“▼”键可查看正、反向有功和正、反向无功各分次谐波电能。如下图所示：

The "Harm. Energy" interface displays three-phase split-phase harmonic energy and total harmonic energy, including combined active power, forward and reverse active power, combined reactive power, four-quadrant reactive power, and forward and reverse apparent power. By pressing the "▲" and "▼" buttons, you can view the harmonic energy of each order for forward and reverse active power, as well as forward and reverse reactive power. As shown in the figure below:

电能计量					电能计量				
2025-08-23 09:23					2025-08-23 09:23				
全波电能		基波电能		谐波电能	全波电能		基波电能		谐波电能
总电能	A相电能	B相电能	C相电能		正向有功	反向有功	正向无功	反向无功	
组合有功	0.000kWh	0.000kWh	0.000kWh	0.000kWh	2次	0.000kWh	0.000kWh	0.000kvarh	0.000kvarh
正向有功	0.000kWh	0.000kWh	0.000kWh	0.000kWh	3次	0.000kWh	0.000kWh	0.000kvarh	0.000kvarh
反向有功	0.000kWh	0.000kWh	0.000kWh	0.000kWh	4次	0.000kWh	0.000kWh	0.000kvarh	0.000kvarh
组合无功1	0.000kvarh	0.000kvarh	0.000kvarh	0.000kvarh	5次	0.000kWh	0.000kWh	0.000kvarh	0.000kvarh
组合无功2	0.000kvarh	0.000kvarh	0.000kvarh	0.000kvarh	6次	0.000kWh	0.000kWh	0.000kvarh	0.000kvarh
一象限无功	0.000kvarh	0.000kvarh	0.000kvarh	0.000kvarh	7次	0.000kWh	0.000kWh	0.000kvarh	0.000kvarh
二象限无功	0.000kvarh	0.000kvarh	0.000kvarh	0.000kvarh	8次	0.000kWh	0.000kWh	0.000kvarh	0.000kvarh
三象限无功	0.000kvarh	0.000kvarh	0.000kvarh	0.000kvarh	9次	0.000kWh	0.000kWh	0.000kvarh	0.000kvarh
四象限无功	0.000kvarh	0.000kvarh	0.000kvarh	0.000kvarh	10次	0.000kWh	0.000kWh	0.000kvarh	0.000kvarh
正向视在	0.000kVAh	0.000kVAh	0.000kVAh	0.000kVAh	11次	0.000kWh	0.000kWh	0.000kvarh	0.000kvarh
反向视在	0.000kVAh	0.000kVAh	0.000kVAh	0.000kVAh	12次	0.000kWh	0.000kWh	0.000kvarh	0.000kvarh

Energy					Energy				
2025-08-23 09:23					2025-08-23 09:23				
RMS Energy		Fund. Energy		Harm. Energy	RMS Energy		Fund. Energy		Harm. Energy
Total	Phase A	Phase B	Phase C		Order	P Positive	P Negative	Q Positive	Q Negative
P Comb.	0.000kWh	0.000kWh	0.000kWh	0.000kWh	2	0.000kWh	0.000kWh	0.000kvarh	0.000kvarh
P Positive	0.000kWh	0.000kWh	0.000kWh	0.000kWh	3	0.000kWh	0.000kWh	0.000kvarh	0.000kvarh
P Negative	0.000kWh	0.000kWh	0.000kWh	0.000kWh	4	0.000kWh	0.000kWh	0.000kvarh	0.000kvarh
Q Comb. 1	0.000kvarh	0.000kvarh	0.000kvarh	0.000kvarh	5	0.000kWh	0.000kWh	0.000kvarh	0.000kvarh
Q Comb. 2	0.000kvarh	0.000kvarh	0.000kvarh	0.000kvarh	6	0.000kWh	0.000kWh	0.000kvarh	0.000kvarh
Q Quad. 1	0.000kvarh	0.000kvarh	0.000kvarh	0.000kvarh	7	0.000kWh	0.000kWh	0.000kvarh	0.000kvarh
Q Quad. 2	0.000kvarh	0.000kvarh	0.000kvarh	0.000kvarh	8	0.000kWh	0.000kWh	0.000kvarh	0.000kvarh
Q Quad. 3	0.000kvarh	0.000kvarh	0.000kvarh	0.000kvarh	9	0.000kWh	0.000kWh	0.000kvarh	0.000kvarh
Q Quad. 4	0.000kvarh	0.000kvarh	0.000kvarh	0.000kvarh	10	0.000kWh	0.000kWh	0.000kvarh	0.000kvarh
S Positive	0.000kVAh	0.000kVAh	0.000kVAh	0.000kVAh	11	0.000kWh	0.000kWh	0.000kvarh	0.000kvarh
S Negative	0.000kVAh	0.000kVAh	0.000kVAh	0.000kVAh	12	0.000kWh	0.000kWh	0.000kvarh	0.000kvarh

4.3.5 需量统计 Demand statistics

“需量统计”界面包含实时需量、最大需量两个三级菜单；通过“◀”“▶”方向键可切换两个菜单。

The "Demand" interface includes two tertiary menus: Real-Time Dem. and Max. Dem.; users can switch between the two menus using the "◀" and "▶" arrow keys.

(1) 实时需量 Real-time demand

“实时需量”界面显示正向、反向总有功功率，正向、反向总无功功率，总视在功率以及三相电流的实时需量。

The "Real-time Dema." interface displays the real-time demand of forward and reverse total active power, forward and reverse total reactive power, total apparent power, and three-phase current.

需量统计				Demand			
2025-08-23 09:23				2025-08-23 09:23			
实时需量		最大需量		Real-Time Dem.		Max. Dem.	
正向总有功功率	0.000kW	A相电流	0.000A	P Positive Dem.	0.000kW	Ia Dem.	0.000A
反向总有功功率	0.000kW	B相电流	0.000A	P Negative Dem.	0.000kW	Ib Dem.	0.000A
正向总无功功率	0.000kvar	C相电流	0.000A	Q Positive Dem.	0.000kvar	Ic Dem.	0.000A
反向总无功功率	0.000kvar			Q Negative Dem.	0.000kvar		
总视在功率	0.000kVA			S Dem.	0.000kVA		

(2) 最大需量 Maximum Demand

“最大需量”界面，分别显示正向、反向总有功功率，正向、反向总无功功率，总视在功率以及三相电流的最大需量及对应时标。

The "Max. Dem." interface displays the maximum demand and corresponding time stamps for forward and reverse total active power, forward and reverse total reactive power, total apparent power, and three-phase current.

量统计			2025-08-23 09:23		Demand			2025-08-23 09:23	
实时需量		最大需量			Real-Time Dem.		Max. Dem.		
		最大需量	发生时间				Occurrence time		
A 相电流	0.000A	0.000A	25-08-23 08:38:00		Ia	0.000A	25-08-23 08:38:00		
B 相电流	0.000A	0.000A	25-08-23 08:38:00		Ib	0.000A	25-08-23 08:38:00		
C 相电流	0.000A	0.000A	25-08-23 08:38:00		Ic	0.000A	25-08-23 08:38:00		
正向总有功功率	0.0000kW	0.0000kW	25-08-23 08:38:00		P Positive	0.0000kW	25-08-23 08:38:00		
反向总有功功率	0.0000kW	0.0000kW	25-08-23 08:38:00		P Negative	0.0000kW	25-08-23 08:38:00		
正向总无功功率	0.0000kvar	0.0000kvar	25-08-23 08:38:00		Q Positive	0.0000kvar	25-08-23 08:38:00		
反向总无功功率	0.0000kvar	0.0000kvar	25-08-23 08:38:00		Q Negative	0.0000kvar	25-08-23 08:38:00		
总视在功率	0.0000kVA	0.0000kVA	25-08-23 08:38:00		S Total	0.0000kVA	25-08-23 08:38:00		

4.3.6 分时计费 Time-based billing

“分时计费”菜单包含 2 个子菜单：费率电能和费率需量，通过“◀”、“▶”方向键可切换子菜单页面。同时显示当前费率，当前运行时段，日时段表号。

The "TOU" menu includes two submenus: TOU Energy and TOU Demand. You can switch between submenu pages using the "◀" and "▶" arrow keys. The current rate, current operating period, and daily period meter number are displayed simultaneously.

(1) 费率电能 TOU Energy

“费率电能”界面显示 8 个费率全波电能，包括组合有功、正、反向有功、组合无功、四象限无功和正、反向视在。可通过“▲”、“▼”键翻页，如下图所示：

The "TOU Energy" interface displays full-wave energy for eight rates, including combined active power, forward and reverse active power, combined reactive power, four-quadrant reactive power, and forward and reverse apparent power. Pages can be turned using the "▲" and "▼" buttons, as shown in the following figure:

(3) 费率需量 TOU Demand

“费率需量”界面显示 8 个费率的最大需量，包括正向有功、反向有功、正向无功、反向无功和总视在需量。可通过“▲”、“▼”键翻页，如下图所示：

分时计费		2025-08-23 09:23				TOU		2025-08-23 09:23					
费率电能		费率需量				TOU Energy				TOU Demand			
		T1	T2	T3	T4	T1	T2	T3	T4				
组合有功	0.000kWh	0.000kWh	0.000kWh	0.000kWh	0.000kWh	Comb. AE	9950.000kWh	10000.000kWh	15000.000kWh	20000.000kWh			
正向有功	0.000kWh	0.000kWh	0.000kWh	0.000kWh	0.000kWh	Pos. AE	0.000kWh	0.000kWh	0.000kWh	0.000kWh			
反向有功	0.000kWh	0.000kWh	0.000kWh	0.000kWh	0.000kWh	Neg. AE	0.000kWh	0.000kWh	0.000kWh	0.000kWh			
组合无功1	0.000kvarh	0.000kvarh	0.000kvarh	0.000kvarh	0.000kvarh	Comb. RE1	0.000kvarh	0.000kvarh	0.000kvarh	0.000kvarh			
组合无功2	0.000kvarh	0.000kvarh	0.000kvarh	0.000kvarh	0.000kvarh	Comb. RE2	0.000kvarh	0.000kvarh	0.000kvarh	0.000kvarh			
一象限无功	0.000kvarh	0.000kvarh	0.000kvarh	0.000kvarh	0.000kvarh	Quad 1. RE	0.000kvarh	0.000kvarh	0.000kvarh	0.000kvarh			
二象限无功	0.000kvarh	0.000kvarh	0.000kvarh	0.000kvarh	0.000kvarh	Quad 2. RE	0.000kvarh	0.000kvarh	0.000kvarh	0.000kvarh			
三象限无功	0.000kvarh	0.000kvarh	0.000kvarh	0.000kvarh	0.000kvarh	Quad 3. RE	0.000kvarh	0.000kvarh	0.000kvarh	0.000kvarh			
四象限无功	0.000kvarh	0.000kvarh	0.000kvarh	0.000kvarh	0.000kvarh	Quad 4. RE	0.000kvarh	0.000kvarh	0.000kvarh	0.000kvarh			
正向视在	0.000kVAh	0.000kVAh	0.000kVAh	0.000kVAh	0.000kVAh	Pos. SE	0.000kVAh	0.000kVAh	0.000kVAh	0.000kVAh			
反向视在	0.000kVAh	0.000kVAh	0.000kVAh	0.000kVAh	0.000kVAh	Neg. SE	0.000kVAh	0.000kVAh	0.000kVAh	0.000kVAh			

The "TOU Demand" interface displays the maximum demand for eight rates, including forward active power, reverse active power, forward reactive power, reverse reactive power, and total apparent demand. You can page through using the "▲" and "▼" buttons, as shown in the following figure:

分时计费					TOU				
费率电能		费率电量			TOU Energy		TOU Demand		
	T1	T2	T3	T4		T1	T2	T3	T4
正向有功	0.0000kW	0.0000kW	0.0000kW	0.0000kW	P Positive	0.0000kW	0.0000kW	0.0000kW	0.0000kW
正向无功	0.0000kvar	0.0000kvar	0.0000kvar	0.0000kvar	Q Positive	0.0000kvar	0.0000kvar	0.0000kvar	0.0000kvar
反向有功	0.0000kW	0.0000kW	0.0000kW	0.0000kW	P Negative	0.0000kW	0.0000kW	0.0000kW	0.0000kW
反向无功	0.0000kvar	0.0000kvar	0.0000kvar	0.0000kvar	Q Negative	0.0000kvar	0.0000kvar	0.0000kvar	0.0000kvar
总视在	0.1000kVA	0.2000kVA	0.3000kVA	0.4000kVA	S Total	5.0000MVA	10.0000MVA	15.0000MVA	20.0000MVA

4.3.7 事件记录 Event recording

“事件记录”菜单包括3个子菜单，包括“监测事件”、“装置日志”、“事件计数”，可通过方向键在子菜单之间切换，按“确认键”进入子菜单。如下图所示：

The "Events" menu comprises three submenus: "SOE Log", "Dev. Log", and "PQ Counters". You can switch between these submenus using the arrow keys, and press the "Confirm" key to enter a submenu. As shown in the figure below:

(1) 监测事件 Monitoring events

“监测事件”界面显示装置上发生的各类事件与触发时间，最大可显示近 1024 条记录。“▲”与“▼”可移动光标在顺序发生的事件之间切换，最新的事件在最前面；“确认键”可查看事件的详细信息，包括事件名称、发生时刻、特征值（特征值显示为一次侧值）等；“◀”与“▶”可直接翻页；按“返回键”可返回上一级菜单。

The "SOE Log" interface displays various events that have occurred on the device along with their trigger times, with a maximum capacity of displaying up to 1024 records. The "▲" and "▼" buttons allow the cursor to be moved to switch between sequentially occurring events, with the latest event displayed at the top. The "Confirm" button allows for the viewing of detailed event information, including the event name, occurrence time, and feature value (displayed as primary side value), etc. The "◀" and "▶" buttons can be used to directly turn pages. Pressing the "Back" button returns to the previous menu level.

事件记录			Events			
监测事件		事件计数	SOE Log		Dev. Log	PQ Counters
序号	事件类型	发生时间	Order	Event Type	Occur. Time	
1	Us偏差越上限	25-08-04 09:55:11.000	1	DWR Triggered Manually	25-08-04 09:55:11.000	
-	-	-	-	-	-	
-	-	-	-	-	-	
-	-	-	-	-	-	
-	-	-	-	-	-	
-	-	-	-	-	-	
-	-	-	-	-	-	
-	-	-	-	-	-	
-	-	-	-	-	-	
-	-	-	-	-	-	

(2) 装置日志 Device log

“装置日志”界面记录装置上的操作记录与操作时间，最新的事件在最前面。按“◀”与“▶”可翻页。

The "Dev. Log" interface records the operation records and operation time on the device, with the latest event at the top. Pressing "◀" and "▶" can turn pages.



(3) 事件计数 Event counting

“事件计数”界面显示暂态事件的统计次数

The "PQ Counters" interface displays the statistical count of transient events



4.3.8 表计状态 Meter status

“表计状态”菜单主要显示表计当前实时告警和 I/O 状态，可通过“◀”、“▶”在子菜单之间切换，按“确认键”进入子菜单。如下图所示：

The "Status" menu primarily displays the current real-time alarms and I/O status of the meter. Users can switch between submenus using "◀" and "▶", and press the "Confirm" button to enter a submenu. As shown in the figure below:

(1) 实时告警 Real-time alerts

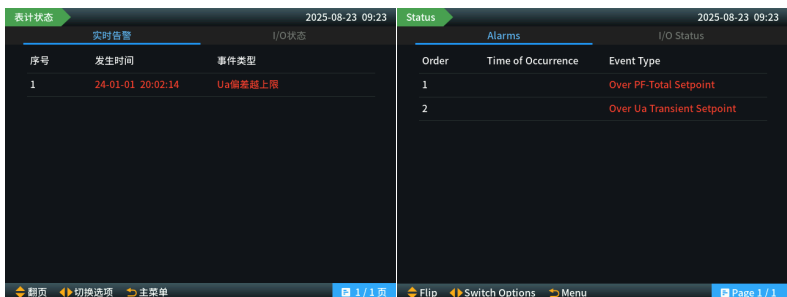

(2) I/O 状态 I/O status



4.3.9 参数设置 Parameter setting

在正常使用装置前，必须先设置好装置的运行参数及显示菜单内容。装置的运行参数决定了装置如何与测量线路连接并测量系统的数据以及如何联网工作。在装置的参数设置中，很多设置是通过选择一些列表选项来进行的。选择时可以通过方向键来选中所要选的项目，然后按“确认”键确定。修改任何参数设置时，都需要输入用户密码，出厂默认密码是“000002”。

Before normal use of the device, it is necessary to set the device's operating parameters and display menu content. The operating parameters of the device determine how it connects with the measurement circuit, measures system data, and operates in a networked manner. In the parameter settings of the device, many settings are made by selecting some list options. When selecting, you can use the arrow keys to highlight the item you want to select, and then press the "Confirm" key to confirm. When modifying any parameter settings, you need to enter a user password. The factory default password is "000002".

“参数设置”菜单分为 10 个菜单，包括基本参数、通信参数、电能质量参数 1、电能质量参数 2、波形记录 1、波形记录 2、时间设置、装置操作、装置信息和监测点信息。

The "Setting" menu is divided into 10 submenus, including Basic, Comm., PQ 1, PQ 2, Record 1, Record 2, Clock, Maintenance, Device Info, and Site Info.

(1) 基本参数 Basic Parameters

“基本参数”界面显示基本设置参数，包括接线方式、背光延时、语言、PT/CT、语言、DO 模式的设定等。

The "Basic" interface displays basic setting parameters, including wiring mode, LCD Timeout, language, PT/CT, language, DO mode settings, etc.

如下图所示 As shown in the figure below:



基本参数设置如下 The basic parameter settings are as follows:

类别 Category	设置参数 Set parameters	缺省值 Default value	功能或设定范围 Function or setting range
接线 Wiring	接线方式 Wiring Mode	三相四线 Three-phase four-wire	三相四线/三相三线 Three-phase four-wire/three-phase three-wire

显示 HMI	背光延时 LCD Timeout	60S	0~300S(0 表示常亮) 0~300S (0 indicates constant on)
	语言 Language	中文 Chinese	中文/英文 Chinese/English
PT 参数	一次电压 PT Primary	1V	1~1000000V
PT parameter	二次电压 PT Secondary	1V	1~380V
CT 参数	一次电流 CT Primary	1A	1~50000A
CT parameters	二次电流 CT Secondary	1A	1~5A
14CT 参数	一次电流 I4 Primary	1A	1~50000A
14CT parameters	二次电流 I4 Secondary	1A	1~5A
DO 模式 DO mode	DO1	电能质量告警关联 Power quality alarm correlation	遥控/DI1~DI6 告警关联/电能质量告警关联 Remote control/DI1~DI6 alarm correlation/power quality alarm correlation
	DO2	电能质量告警关联 Power quality alarm correlation	遥控/DI1~DI6 告警关联/电能质量告警关联 Remote control/DI1~DI6 alarm correlation/power quality alarm correlation
	DO3	电能质量告警关联 Power quality alarm correlation	遥控/DI1~DI6 告警关联/电能质量告警关联 Remote control/DI1~DI6 alarm correlation/power quality alarm correlation
	DO4	电能质量告警关联 Power quality alarm correlation	遥控/DI1~DI6 告警关联/电能质量告警关联 Remote control/DI1~DI6 alarm correlation/power quality alarm correlation

(2) 通信设置 Communication Settings

“通信设置”界面显示 RS485-1 和 RS485-2 口通信参数以及以太网口 1、以太网口 2 通信参数，如下图所示：

The "Comm." interface displays the communication parameters for RS485-1 and RS485-2 ports, as well as the communication parameters for Ethernet Port 1 and Ethernet Port 2, as shown in the figure below:



通信参数设置如下：

The communication parameter settings are as follows:

类别 Category	设置参数 Set parameters	缺省值 Default value	功能或设定范围 Function or setting range
RS485-1	波特率 Baud rate	9600	4800/9600 /19200/38400/115200bps
	校验位 Parity	无 Nothing	无/奇/偶 None/Odd/Even
	协议地址 Unit ID	1	装置 ID 号：1~247，在同一通讯链路中，每台装置应该有唯一的 ID 号

			Device ID number: 1~247. In the same communication link, each device should have a unique ID number
RS485-2	波特率 Baud rate	9600	4800/9600 /19200/38400/115200bps
	校验位 Parity	无 Nothing	无/奇/偶 None/Odd/Even
	协议地址 Unit ID	1	装置 ID 号: 1~247, 在同一通讯链路中, 每台装置应该有唯一的 ID 号 Device ID number: 1~247. In the same communication link, each device should have a unique ID number
以太网口 1 Ethernet port 1	IP 地址 IP address	192.168.0.101	网络参数设置需要满足以下要求: The network parameter settings must meet the following requirements: 1) IP 地址、子网掩码不能为 0 (网关为 0 表示没有网关) The IP address and subnet mask cannot be 0 (a gateway of 0 indicates the absence of a gateway) 2) IP 地址、网关最高字节取值范围为 1~223 The highest byte value range for IP addresses and gateways is 1~223 3) IP 地址、网关不能为 127.x.x.x The IP address and gateway cannot be 127.x.x.x 4) 1/2 口需至少有一个 IP 地址与网关设置在同一网段, 否则参数保存失败。 At least one IP address of the 1/2 port needs to be set on the same network segment as the gateway, otherwise the parameter saving will fail. 5) 网络 ID 不能为 0, 也不能全为 1 (二进制) The network ID cannot be 0, nor can it consist entirely of 1s (in binary) 6) 主机 ID 不能为 0, 也不能全为 1 (二进制) IP 地址 2 The host ID cannot be 0, nor can it be all 1s (in binary) for the IP address 2
	子网掩码 mask	255.255.255.0	
	默认网关 GW	192.168.0.1	
以太网口 2 Ethernet port 2	IP 地址 IP address	192.168.1.102	
	子网掩码 mask	255.255.255.0	
	默认网关 GW	192.168.0.2	

(3) 电能质量参数 1 Power quality parameter 1

“电能质量参数 1”界面显示暂态和瞬态相关参数的设定。如下图所示:

The "PQ 1" interface displays the settings for transient and instantaneous related parameters, as shown in the figure below:



暂瞬态参数设置如下：

The transient parameter settings are as follows:

类别 Category	设置参数 Set parameters	缺省值 Default value	功能或设定范围 Function or setting range
参数 Parameter	标称线电压 Ull Nominal	381.051	
暂态 PQ Events	投退 Enable	投入 YES	投入/退出 YES/NO
	参考电压 Reference voltage	额定电压 Rated voltage	额定电压(Un)/滑动参考电压 Rated voltage (Un)/sliding reference voltage
	电压暂降阈值 Dip Thres.	90%	10%~90%
	电压暂降迟滞 Hysteresis	2%	0.5%~10%
	电压暂降触发 Trigger	波形记录 Waveform recording	无/DO1~4 / 波形记录/扰动记录/有效值记录 None / DO1~4 / WFR / DWR / RMSR
	电压暂升阈值 Swell Thres	110%	110%~200%
	电压暂升迟滞 Hysteresis	2%	0.5~10%
	电压暂升触发 Trigger	波形记录 Waveform recording	无/DO1~4 / 波形记录/扰动记录/有效值记录 None / DO1~4 / WFR / DWR / RMSR
	电压中断阈值 Inter.Thres	10%	1~10%
	电压中断迟滞 Hysteresis	2%	0.5~10%
	电压中断触发 Trigger	波形记录 Waveform recording	无/DO1~4 / 波形记录/扰动记录/有效值记录 None / DO1~4 / WFR / DWR / RMSR
瞬态 transient	瞬态功能投退 Enable	退出 NO	投入/退出 YES/NO
	瞬态限值 Thres.	35%	5%~500%
	瞬态触发参数 Transient trigger	波形记录 Waveform recording	无/DO1~4 / 波形记录/扰动记录/有效值记录 None / DO1~4 / WFR / DWR / RMSR

(4) 电能质量参数 2 Power quality parameters 2

“电能质量参数 2”界面显示 RVC 和突变量相关参数设定，如下图：

The "Power Quality Parameter 2" interface displays the settings for RVC and mutation-related parameters, as shown in the figure

below:



RVC（电压快速变动）参数和突变量参数设置如下：

The settings for the RVC (Rapid Voltage Change) parameter and the sudden change parameter are as follows:

类别 Category	设置参数 Set parameters	缺省值 Default value	功能或设定范围 Function or setting range
电压快速变动 Rapid voltage	投退 Enable	退出 NO	投入/退出 YES/NO
	限值 Thres.	5%	(0.2%~10%) Un

fluctuation	迟滞 Hysteresis	2.5%	(0.1%~5%) Un
	触发参数 Trigger	波形记录 Waveform recording	无/DO1/DO2/DO3/DO4/波形记录/扰动记录/有效值记录 None / DO1~4 / WFR / DW / RMSR
突变量 Sudden change	电压投退 Volt. Enable	退出 NO	投入/退出 YES/NO
	电压限值 Volt. Thres	100	0.57~100V
	电流投退 Cur. Enable	退出 NO	投入/退出 YES/NO
	电流限值 Cur. Thres	5	0.10~5A
	触发参数 Trigger	波形记录 waveform recording	无/DO1/DO2/DO3/DO4/波形记录/扰动记录/有效值记录 None / DO1~4 / WFR / DW / RMSR

(5) 波形记录 1 Waveform Record 1

“波形记录 1”界面显示波形记录、扰动记录和有效值记录等参数的设置，如下图所示：

The "Waveform Record 1" interface displays the settings for parameters such as waveform records, disturbance records, and effective value records, as shown in the figure below:



波形记录参数设置如下：

The waveform recording parameter settings are as follows:

类别 Category	设置参数 Set parameters	缺省值 Default value	功能或设定范围 Function or setting range
波形记录 Waveform recording	录波格式 WFR	1024×10	1024 点/周波×10 周波 1024 points/cycle × 10 cycles 512 点/每周波×20 周波 512 points/cycles × 20 cycles 256 点/每周波×40 周波 256 points/cycles × 40 cycles 128 点/每周波×80 周波 128 points/cycles × 80 cycles
	触发前周波数 Pre-TC	4	2~4
	触发后周波数 Post-TC	4	2~4
扰动记录 Disturbance record	触发前周波数 Pre-TC	5	5~10
有效值记录 Effective value record	触发前记录点数 Pre-TS	100	100~500
	采样间隔 Interval	2.5 周波 2.5 cycles	0.5 周波~60 周波 0.5 cycles to 60 cycles
	通道 1 Channel 1	Ua	Ua / Ub / Uc / Uab / Ubc / Uca / Ia / Ib / Ic / 14

通道 2Channel 2	Ub	频率 / 频率偏差
通道 3Channel 3	Uc	Frequency / Frequency deviation
通道 4Channel 4	Ia	Pa / Pb / Pc
通道 5Channel 5	Ib	Qa / Qb / Qc
通道 6Channel 6	Ic	Sa / Sb / Sc
通道 7Channel 7	频率 frequency	PFa / PFb / PFc
通道 8Channel 8	频率偏差 frequency deviation	空 Empty

(6) 波形记录 2 Waveform Record 2

“波形记录 2”界面可以对定时录波的参数(投退、启动日期、启动时间、间隔时间、录波次数)进行设置，如下图所示：

The "Record 2" interface allows for the setting of parameters for scheduled waveform recording, including activation/deactivation, start date, start time, interval time, and recording frequency, as shown in the figure below:

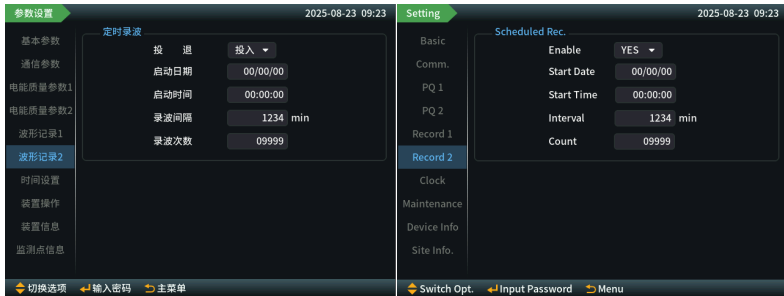

定时录波参数设置如下表：

The settings for the scheduled wave recording parameters are as follows:

类别 Category	设置参数 Set parameters	缺省值 Default value	功能或设定范围 Function or setting range
定时录波 Scheduled wave recording	投退 Enable	退出 NO	投入/退出 YES/NO
	启动日期 Start date	25/04/01	年 (00~99) / 月 (1~12) / 日 (1~31) Year (00~99)/Month (1~12)/Day (1~31)
	启动时间 Startup time	00:00:00	时 (00~23) : 分 (00~59) : 秒 (00~59) Hour (00~23): Minute (00~59): Second (00~59)
	录波间隔 (分钟) interval (minutes)	60	1~1440min
	录波次数 count	1	1~10000

(7) 时间设置 Time Settings

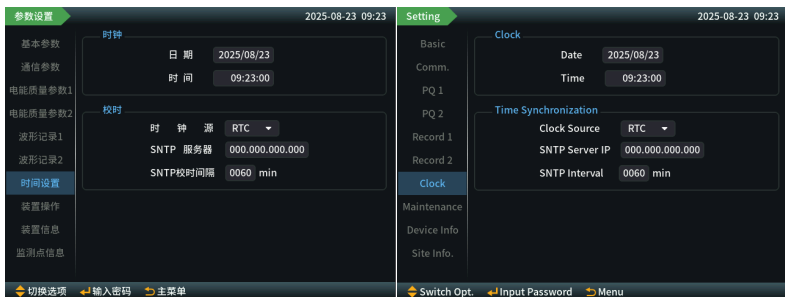

类别 Category	设置参数 Set parameters	缺省值 Default value	功能或设定范围 Function or setting range
时钟 Clock	日期 Date	无 Nothing	年 (2000~2099) / 月 (1~12) / 日 (1~31) Year (2000~2099) / Month (1~12) / Day (1~31)
	时间 Time	无 Nothing	时 (00~23) : 分 (00~59) : 秒 (00~59) Hour (00~23); Minute (00~59); Second (00~59)
校时 Time synchronization	时钟源 Clock Source	RTC	RTC/SNTP/IRIG-B/PPS
	SNTP 服务器 SNTP Server IP	203.107.6.88	0.0.0.0~255.255.255.255
	SNTP 校时间隔 SNTP Interval	60min	10~1440min

(8) 装置操作装置操作 Device operation



类别 Category	设置参数 Set parameters	缺省值 Default value	功能或设定范围 Function or setting range
修改密码 Change password	输入新密码 New password	000002	000000~999999
	确认新密码 Confirm Password	000002	000000~999999
清除操作	清除全部事件	--	二次确认

Clear operation	All Events		Second confirmation
	清除全部需量 All Demands	--	二次确认 Second confirmation
	清除电能数据 Energy	--	二次确认 Second confirmation
	清除 PQ 事件计数 PQ Counters	--	二次确认 Second confirmation
USB 操作 USB operation	更新程序 Update Program	--	升级程序 Upgrade program
	更新计量程序 Update Meter		升级计量程序 Upgrade Meter

(9) 装置信息 Device information

“装置信息”界面显示装置基本信息、版本信息及自检信息，其中，基本信息通过通信可设置，通过显示可查看；自检信息中可显示计量 状态和存储卡存储状态。如下图所示：

The "Device Information" interface displays basic device information, version information, and self-check information. Among them, basic information can be set through communication and viewed through display; self-check information can display the metering status and storage card storage status. As shown in the figure below:



类别 Category	显示参数 Display parameters
基本信息 Basic Information	装置型号 Model
	序列号 Serial number
	MAC 地址 1 MAC address 1
	MAC 地址 2 MAC address 2
	Modbus 端口号 Modbus port
版本信息 Version Information	功能程序版本 Firmware
	计量程序版本 Measurement
自检信息 Self-check information	计量状态 Measurement Status
	存储状态 Memory status
	SD 卡容量 Storage

(10) 监测点信息 Monitoring point information

“监测点信息”界面显示变电所信息和监测点信息，通过上位机软件进行修改。如下图所示：

The "Monitoring Point Information" interface displays substation information and monitoring point information, which can be modified through the host computer software. As shown in the figure below:



类别 Category	显示参数 Display parameters
变电站信息 Substation information	供电公司 Power supply company
	县供电公司 County Power Supply Company
	变电所 Substation
	变电所电压等级 Voltage level of substation
监测点信息 Monitoring point information	母线名称 Busbar name
	监测点名称 Name of monitoring point
	监测点电压等级 Voltage level of monitoring point
	资产管理 IDAsset management ID
	监测网管理 IDMonitoring network management ID
	投运日期 Commissioning Date
	最小短路容量 Minimum short-circuit capacity
	供电设备容量 Power supply equipment capacity
	用户协议容量 User agreement capacity

第五章 安装 Chapter 5: Installation

5.1 安装预防、准备 Installation prevention and preparation

请在开始操作前阅读

Please read before starting the operation

本章包含重要的安全预防信息，在安装、服务或维护电气设备前必须遵守这些指导。仔细阅读并遵循下列安全预防指导。

This chapter contains important safety precautions that must be followed before installing, servicing, or maintaining electrical equipment. Carefully read and follow the safety precautions below.



电击，烧毁或爆炸的危险，所以只有合格的操作人员才能安装本设备。此工作应在阅读了该全部指导后开展。在进行安装，检验，测试或维护前，应断开所有的电源连接。请依照说明书中的接线说明接线，接完后要认真核对接线是否正确无误。意识到潜在的危险，工作人员需佩戴保护设备，仔细检查工作接线和安装是否正确。安装或者拆除仪表时，请确认电源、待测信号源及相关电源是否完成断开。



There is a risk of electric shock, burnout, or explosion, so only qualified operators are authorized to install this equipment. This work should be carried out after reading the entire instruction manual. Before conducting installation, inspection, testing, or maintenance, all power connections should be disconnected. Please follow the wiring instructions in the manual to connect the wires, and carefully verify that the wiring is correct after completion. Aware of the potential dangers, staff members need to wear protective equipment and carefully check whether the work wiring and installation are correct. When installing or removing instruments, please confirm that the power supply, signal source to be measured, and related power sources have been completely disconnected.

5.2 安装信息 Installation Information

5.2.1 安装环境和位置 Installation environment and location

装置应安装在干燥、清洁、远离热源和强电磁场的地方，避免阳光直射。位置通常安装在开关柜中，可使装置不受油、污物、灰尘、腐蚀性气体或其他有害物质的侵袭。安装时要注意检修方便，有足够的空间放置有关的线、端子排、短接板和其他必要的设备。

The device should be installed in a dry, clean location, away from heat sources and strong electromagnetic fields, and protected from direct sunlight. It is typically installed in a switch cabinet, which shields the device from oil, dirt, dust, corrosive gases, or other harmful substances. During installation, attention should be paid to ensuring easy maintenance and sufficient space for placing relevant wires, terminal blocks, shorting boards, and other necessary equipment.

5.2.2 安装尺寸 (单位: mm; 公差: ± 0.5) Installation dimensions (unit: mm; tolerance: ± 0.5)

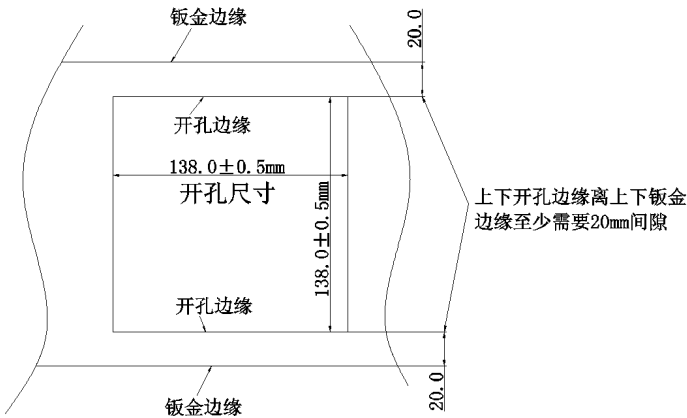
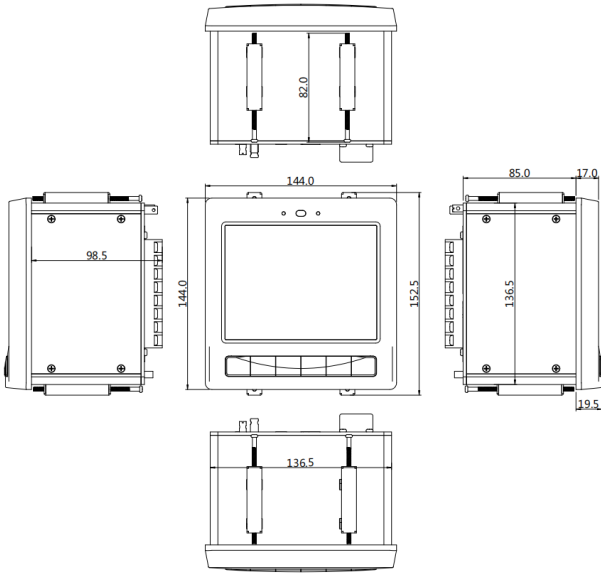

钣金边缘	Sheet metal edge	开孔边缘	Perforation edge
开孔尺寸	Opening size		
上下开孔边缘离上下钣金边缘至少需要 20mm 间隙		At least 20mm gap is required between the edges of the upper and lower openings and the edges of the upper and lower sheet metal	

注: 外形尺寸: 长*宽*高 (不包含端子): $(144\pm 0.5)\text{mm}\times(144\pm 0.5)\text{mm}\times(85\pm 0.5)\text{mm}$

Note: Overall dimensions: Length * Width * Height (excluding terminals): $(144\pm 0.5)\text{mm}\times(144\pm 0.5)\text{mm}\times(85\pm 0.5)\text{mm}$

长*宽*高 (含端子): $(144\pm 0.5)\text{mm}\times(144\pm 0.5)\text{mm}\times(118\pm 1)\text{mm}$

Length * width * height (including terminals): $(144\pm 0.5)\text{mm}\times(144\pm 0.5)\text{mm}\times(118\pm 1)\text{mm}$

开孔尺寸: $(138\pm 0.5)\text{mm}\times(138\pm 0.5)\text{mm}$

Hole size: $(138\pm 0.5)\text{mm}\times(138\pm 0.5)\text{mm}$

5.3 端子定义 Terminal definition

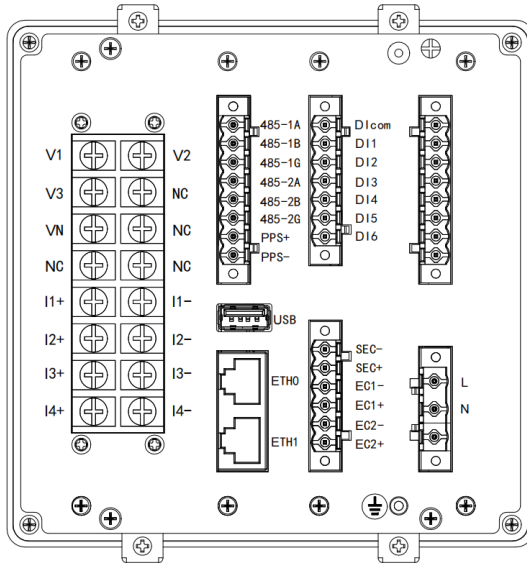

端子定义 Terminal definition	注释 Note	端子定义 Terminal definition	注释 Note
V1	A 相电压输入 A phase voltage input	DIcom	开关量输入公共端 Switching input common terminal
V2	B 相电压输入 B phase voltage input	DI1	第一路开关量输入 First channel switch input
V3	C 相电压输入 C phase voltage input	DI2	第二路开关量输入 Second channel switch input
NC	预留 Reserve	DI3	第三路开关量输入 Third channel switch input
VN	零线电压输入 Neutral line voltage input	DI4	第四路开关量输入 Fourth channel switch input
NC	预留 reserve	DI5	第五路开关量输入 Fifth channel switch input
I1+	A 相电流流入 A phase current flows in	DI6	第六路开关量输入 Sixth channel switch input
I1-	A 相电流流出 A phase current flows out	SEC+/SEC-	秒脉冲口 Millisecond pulse port
I2+	B 相电流流入 B-phase current inflow	EC1+/EC1-	有功电能脉冲口 Active energy pulse port
I2-	B 相电流流出 B-phase current outflow	EC2+/EC2-	无功电能脉冲口 Reactive energy pulse port
I3+	C 相电流流入 C-phase current inflow	DO1+/DO1-	第一路继电器输出 First relay output

I3-	C 相电流流出 C-phase current outflow	DO2+/DO2-	第二路继电器输出 Second relay output
I4+	零线电流流入 Zero line current inflow	DO3+/DO3-	第三路继电器输出 Third relay output
I4-	零线电流流出 Zero line current flowing out	DO4+/DO4-	第四路继电器输出 Fourth relay output
485-1A/1B/1G	RS485 接口 1 RS485 interface 1	L/+	交流电源火线/直流电源正极 AC power live wire/DC power positive pole
485-2A/2B/2G	RS485 接口 2 RS485 interface 2	N/-	交流电源零线/直流电源负极 AC power neutral line/DC power negative pole
PPS+/PPS-	PPS 对接接口 PPS timing interface	USB	
ETH0	网络通信 RJ45 接口 1 Network communication RJ45 interface 1		外壳接地端子，请务必接地并确保接触良好。 For the shell grounding terminal, please ensure it is grounded and in good contact.
ETH1	网络通信 RJ45 接口 2 Network communication RJ45 interface 2		

5.4 接线图纸 Wiring diagram



(1) PT 的二次侧不能短路;

The secondary side of the PT cannot be short-circuited;

(2) CT 的二次侧不能开路，在断开 CT 和监控回路连接时，将 CT 的二次侧短接;

The secondary side of the CT cannot be open-circuited. When disconnecting the CT from the monitoring circuit, short-circuit the secondary side of the CT;

(3) 装置适用于各种三相系统，请仔细阅读本章节，以选择合适的接线方式;

The device is suitable for various three-phase systems. Please read this section carefully to select the appropriate wiring method;

(4) 接入的电压，应在装置的额定电压范围之内;

The voltage received should be within the rated voltage range of the device;

(5) PT 一次侧必须有断路器或熔断器提供保护，如果使用的 PT 额定容量大于 25VA，则 PT 二次侧也要装熔断器;

The primary side of the PT must be protected by a circuit breaker or a fuse. If the rated capacity of the PT used is greater than 25VA, a fuse should also be installed on the secondary side of the PT;

(6) PT 和 CT 一次侧的励磁将在 PT 和 CT 二次侧电路产生较大的电压和电流，所以在安装仪表时一定要必要的安全措施，例如拆下 PT 的熔断器、短接 CT 二次侧;

The excitation on the primary side of PT and CT will generate significant voltage and current in the secondary side circuits of PT and CT. Therefore, it is essential to take necessary safety measures when installing instruments, such as removing the fuse of PT and short-circuiting the secondary side of CT;

5.4.1 电源 Power supply

用于交流系统时，相线接 L/+端，中性线接 N/-端；电源范围 AC85V~265V，50Hz/60Hz。

When used in an AC system, connect the phase line to the L/+ terminal and the neutral line to the N/- terminal; the power supply range is AC85V~265V, 50Hz/60Hz.

用于直流系统时，正极接 L/+端，负极接 N/-端；电源范围 DC100V~330V

When used in a DC system, connect the positive pole to the L/+ terminal and the negative pole to the N/- terminal; the power supply range is DC100V~330V

5.4.2 V 电压电流 Voltage and current

(1) 三线 四线接法（无 PT，4CT） Three-wire and four-wire connection method (without PT, 4CT)

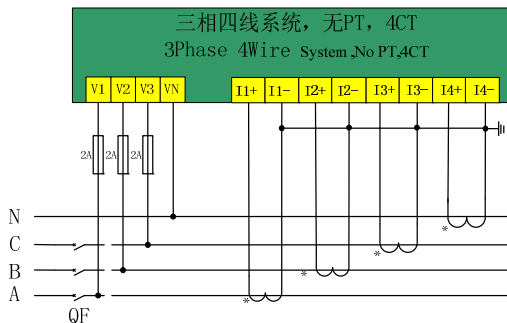

装置的接线方式应设为“三相四线”，设置对应电流变比

The wiring method of the device should be set to "three-phase four-wire", with corresponding current transformation ratio set

(2) 三线四线接法（3PT，4CT） Three-wire and four-wire connection method (3PT, 4CT)

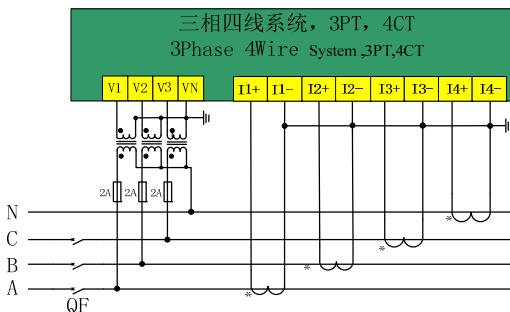

装置的接线方式应设为“三相四线”，设置对应电压变比和电流变比

The wiring method of the device should be set to "three-phase four-wire", with corresponding voltage transformation ratio and current transformation ratio set

(3) 三相三线（无 PT/2CT） Three-phase three-wire (without PT, 2CT)

当测量线路为三相三线系统时，接线示意图如下图所示，装置的接线方式应设为“三线星型”。

When the measurement circuit is a three-phase three-wire system, the wiring diagram is shown below, and the wiring mode of the device should be set to "three-wire star type".

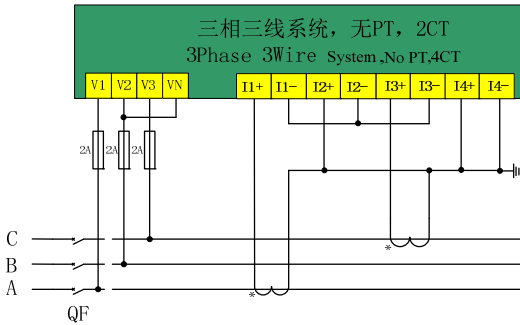

装置的接线方式应设为“三相三线”，设置对应电流变比

The wiring method of the device should be set to "three-phase three-wire" and the corresponding current transformation ratio should be set

(4) 三相三线 (3PT,2CT) Three-phase three-wire (2PT, 2CT)

当测量线路为三线角形接法时，接线示意图如下图所示，装置的接线方式应设为“角形接线”。

When the measurement circuit adopts a three-wire angular connection method, the wiring diagram is shown below, and the wiring mode of the device should be set to "angular connection".

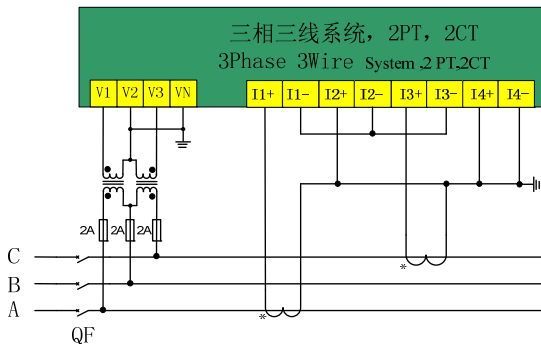

装置的接线方式应设为“三相四线”，设置对应电压变比和电流变比

The wiring method of the device should be set to "three-phase four-wire", with corresponding voltage transformation ratio and current transformation ratio set

5.4.3 通讯 Communication

RS-485通信口，端子标记为A、B。

RS-485 communication port, with terminals labeled A and B.

RS-485 通信方式允许一条总线上最多接 32 台仪表，通过一个 RS-485 转换器与上位机连接。通信电缆可以采用普通的屏蔽双绞线，总长度不宜超过 1200 米，各个设备的 RS-485 口正负极性必须连接正确。如果屏蔽双绞线较长，建议在其末端接一个约 120Ω 的电阻以提高通信的可靠性。

The RS-485 communication method allows up to 32 instruments to be connected on one bus, which is then linked to the host computer via an RS-485 converter. The communication cable can be a standard shielded twisted pair, with a total length not exceeding 1200 meters. The positive and negative polarities of the RS-485 ports of each device must be connected correctly. If the shielded twisted pair is long, it is recommended to connect a resistor of approximately 120Ω at its end to enhance communication reliability.

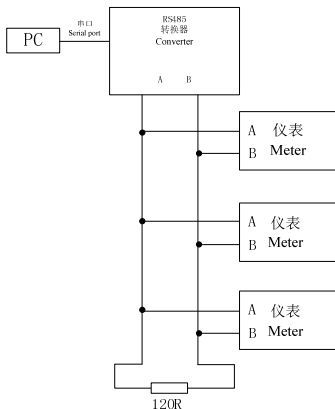

5.4.4 开关输入 Switch input

装置提供 6 个光耦 DI 输入，并提供 12V 内置激励电源，可接入开关信号，接线图如下所示：

The device provides 6 optocoupler DI inputs and a built-in 12V excitation power supply, which can be connected to switch signals.

The wiring diagram is shown below:

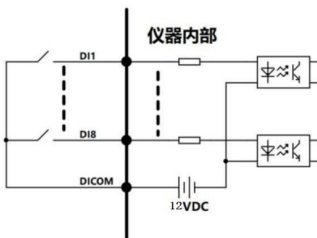

DI 接线图 DI wiring diagram

仪器内部	Inside meter
------	--------------

5.4.5 继电器输出 Relay output

仪器提供 4 路继电器输出，标记为 DO1+/-DO4+/-，4 路均为常开触点，DO 输出接线如下图所示：

The instrument provides 4-channel relay output, labeled as DO1+/-DO4+/- . All 4 channels feature normally open contacts. The

wiring for DO output is shown in the figure below:

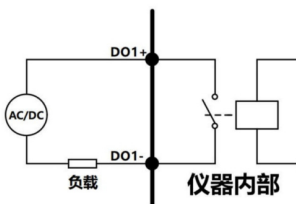

继电器输出接线图 Relay output wiring diagram

仪器内部	Inside meter
负载	Load

5.4.6 脉冲端子接线 Pulse terminal wiring

仪器提供两路EC 输出功能，端子标记为EC1+/-和EC2+/-，可做为其他报警功能输出。使用时 EC+接外部直流电源正极，EC-接负载后到外部直流电源负极，EC 输出接线示意图如下：

The instrument provides two-channel EC output function, with terminals marked as EC1+/- and EC2+/-, which can be used as outputs for other alarm functions. When in use, connect EC+ to the positive terminal of the external DC power supply, and connect EC- to the load and then to the negative terminal of the external DC power supply. The schematic diagram of EC output wiring is as follows:

装置提供 2 个脉冲输出 EC1+、EC1-和 EC2+、EC2-。EC1+、EC1-为有功电能脉冲输出；EC2+、EC2-为无功电能脉冲，

The device provides two pulse outputs: EC1+, EC1-, and EC2+, EC2-. EC1+, EC1- are for active energy pulse output; EC2+, EC2- are for reactive energy pulse output,

有功/无功脉冲输出，主要用于有功/无功电能准确度测试，脉冲宽度为 80ms±20ms；电脉冲经光电隔离后输出。

Active/reactive pulse output, primarily used for accurate testing of active/reactive electrical energy, with a pulse width of 80ms±20ms; the electrical pulse is output after being photoelectrically isolated.

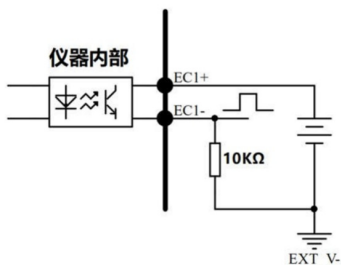

EC 输出接线（EC1 为例，EC2 同理）

EC output wiring (taking EC1 as an example, EC2 is similar)

仪器内部	Inside meter
------	--------------

5.4.7 秒脉冲端子接线 Wiring of second pulse terminal

仪器提供一路秒信号输出功能，端子标记为SEC+/-。使用时 SEC+接外部直流电源正极，SEC-接负载后到外部直流电源负极，SEC 输出接线示意图如下：

The instrument provides a one-way second signal output function, with the terminal marked as SEC+/-。When in use, SEC+ is connected to the positive terminal of the external DC power supply, and SEC- is connected to the load and then to the negative terminal of the external DC power supply. The schematic diagram of SEC output wiring is as follows:

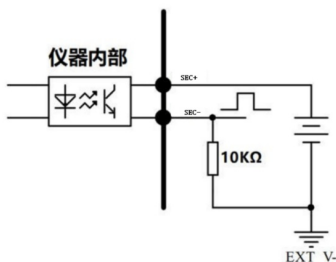

仪器内部	Inside meter
------	--------------

秒脉冲输出，主要是用时钟精度测试。

The second pulse output is primarily used for clock accuracy testing.

5.4.8 PPS 接线 PPS wiring

端子标记为+、-，当进行 PPS 对时时，PPS 对时装置的 +端（信号）接+，-端（地）接-。

The terminals are marked with + and -. When performing PPS timing, connect the + terminal (signal) of the PPS timing device to +, and connect the - terminal (ground) to -.

第六章 维护和故障排除 Chapter 6 Maintenance and Troubleshooting

6.1 故障排除 Troubleshooting

可能问题 Possible issues	可能原因 Possible reasons	可能解决方案 Possible solutions
上电后无显示 No display after power-on	电源未能加入到设备上 The power supply failed to be connected to the device	检查设备 L/+和 N/-端子上是否加入了正确的工作电压 Check whether the correct operating voltage is applied to the L/+ and N/- terminals of the device
加信号后测量数据不准确或显示为 0. The measurement data is inaccurate or displayed as 0 after adding a signal	电压测量不正确 The voltage measurement is incorrect	检查电压信号是否正确接入设备 Check whether the voltage signal is correctly connected to the device 检查电压测量信号是否在设备测量范围内 Check whether the voltage measurement signal falls within the measurement range of the device 检查 PT 变比参数是否设置正确 Check whether the PT transformation ratio parameter is set correctly
	电流测量不准确 The current measurement is inaccurate	检查电流信号是否正确接入设备 Check whether the current signal is correctly connected to the device 检查电流测量信号是否在设备测量范围内 Check whether the current measurement signal is within the measurement range of the device 检查 CT 变比参数是否设置正确 Check whether the CT transformation ratio parameters are set correctly
	功率测量不准确 The power measurement is inaccurate	检查测量模式设置是否正确 Check whether the measurement mode setting is correct 检查电压电流对应相序是否正确 Check whether the voltage and current correspond to the correct phase sequence 检查电流方向是否正确 Check whether the current direction is correct
开关量状态不变化 The switch state remains unchanged	开关量输入错误 Switch input error	检查设备是否配有开关量输入功能 Check whether the equipment is equipped with switch input function 检查外部接线是否正确 Check whether the external wiring is correct
继电器不动作 The relay does not operate	没有接收到控制命令 No control command received	检查相关设置是否正确（在哪种模式下） Check whether the relevant settings are correct (in which mode) 若是通讯控制，检查通讯是否成功 If it is about communication control, check whether the communication is successful
	无继电器功能 No relay function	检查设备是否配有继电器功能 Check whether the equipment is equipped with relay

		function
上位机不能与设备通讯 The host computer cannot communicate with the device	通讯接线错误 Communication wiring error	检查设备通讯线是否连接正确 Check whether the communication cable of the device is properly connected
	通讯参数不正确 The communication parameters are incorrect	检查通讯地址是否正确 Check whether the mailing address is correct 检查通讯波特率是否正确 Check whether the communication baud rate is correct 检查通讯校验位是否正确 Check whether the communication check digit is correct
	通讯链路受影响 The communication link is affected	检查同一个通讯链路上是否有相同参数的设备 Check if there are devices with the same parameters on the same communication link 检查通讯屏蔽层是否良好接地 Check whether the communication shielding layer is properly grounded 检查通讯电缆是否断开 Check if the communication cable is disconnected

注：如果有一些无法解决的问题，请及时与我们公司的售后服务部门联系。

Note: If there are any unresolved issues, please contact our company's after-sales service department in a timely manner.

第七章 质量保证 Chapter 7 Quality Assurance

7.1 质量保证 Quality Assurance

所有售给用户的新仪表，在通电运行后 12 个月或收到货后 18 个月内，对其因设计、材料和工艺引起的故障实行免费质量保证，如经认定产品符合上述质保条件，我公司负责免费维修。

All new instruments sold to users are covered by a free quality assurance for malfunctions caused by design, materials, and workmanship, within 12 months after being powered on or 18 months after receipt. If the product is confirmed to meet the aforementioned warranty conditions, our company will be responsible for free repairs.

7.2 质量限制 Quality restrictions

以下装置的问题不属免费质保范围：

The following issues with the device are not covered by the free warranty:

- 由于不正确的安装、使用、存储引起的损坏。
- Damage caused by incorrect installation, use, or storage.
- 超出产品规定的非正常操作和应用条件。
- Abnormal operation and application conditions beyond the product specifications.
- 由非本公司授权的机构或人修理了的仪表。
- Instruments repaired by institutions or individuals not authorized by our company.
- 超出免费质保年限了的仪表。
- Instruments that have exceeded the free warranty period.

注：以上图片仅供参考，产品以实物为准。

Note: The above pictures are for reference only. The actual product is subject to the actual product.

