

# YDS60-C24 Smart Power Sensor

## Quick Guide

**Issue: 01**

**Date: 2022-11-20**

# 1 Overview

## 1.1 Model Naming Conventions

YDS60-C24

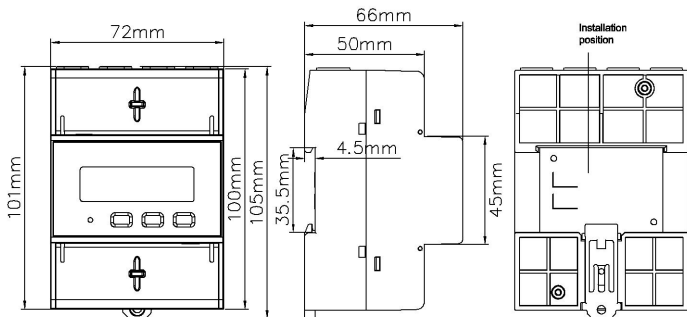

### NOTE

The dimensional tolerance is  $\pm 1$  mm.

## 1.2 Appearance

Specifications on the front panel



Nameplate

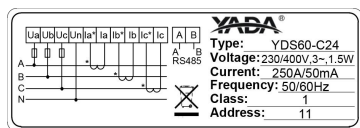

### 1.3 Key Specifications

Category	YDS60-C24
Nominal voltage	230V AC/400V AC, 50Hz/60Hz
Current measurement range	0~250A
Voltage measurement range	line voltage 90V~500V
Electricity metering accuracy	Class 1 (error within $\pm 1\%$ )
Power grid system	Three -phase four-wire or three-phase three-wire
Baud rate	4800/9600/19200/115200 bps (default value: 9600 bps)
Operating temperature	-25°C to +60°C
Installation mode	Guide rail-mounted
Certification	CE, RCM, and UKCA

### 1.4 Port Definition

- Voltage Input:  $3 \times 230/400V$  or  $3 \times 400V$
- Current Transformer(CT): 250A/50mA

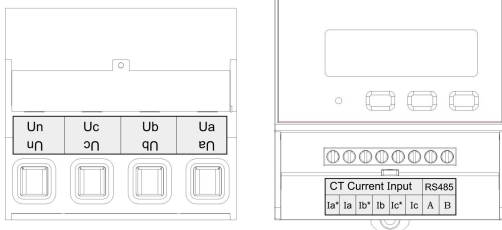

#### NOTE

The protective film of the nameplate can be tear off.

## 2 Installing the YDS60-C24

1. Install the Smart Power Sensor on the standard guide rail of DIN35mm.
2. Press the Smart Power Sensor downwards onto the guide rail, and then push it in place along the guide rail.

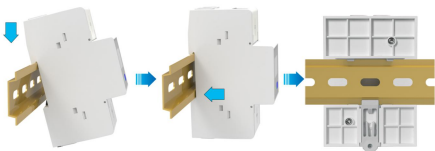

## 3 Installing Cables

### 3.1 Prepare cables

Cable	Port	Type	Conductor Cross-sectional Area Range	Outer Diameter	Source
voltage cable	Ua-3	Single-core outdoor copper cable	1.5~4mm <sup>2</sup>	3~8mm	Prepared by the customer
	Ub-6				
	Uc-9				
	Un-10				
current transformer cable	Ia* - 13	/	/	/	Supplied with current transformers
	Ia - 14				
	Ib* - 16				
	Ib - 17				
	Ic* - 19				
	Ic - 21				
Communications cable	RS485A - 24	Two-core outdoor shielded twisted pair copper cable	0.25~1mm <sup>2</sup>	4~11mm	Prepared by the customer
	RS485B - 25				

## 3.2 Connecting Diagram

### Three-phase four-wire connection

1. Connect the Ua, Ub, Uc, and Un voltage cables to terminals 3, 6, 9, and 10 of the sensor.
2. Connect the current transformer Ia\* (white wire) and Ia (blue wire) used for phase A to terminals 13 and 14 of the sensor; Current transformer Ib\* (white wire) and Ib (blue wire) for phase B connected to terminals 16 and 17 of the sensor; Current transformer Ic\* (white line) and Ic (blue line) for phase C connected to terminals 19 and 21 of the sensor.
3. Connect RS485A and RS485B to the communication host.

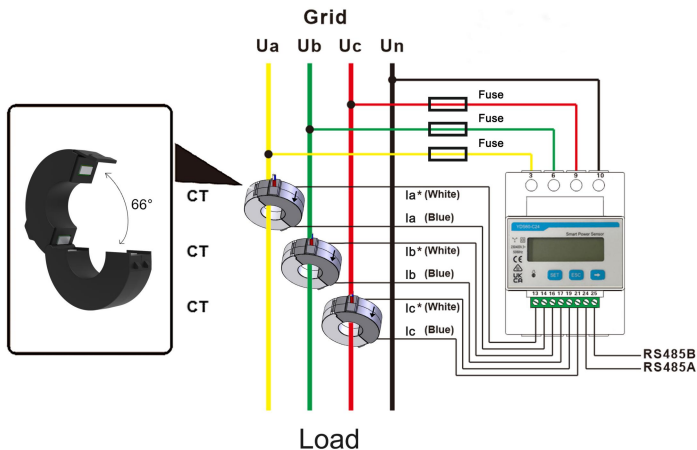

#### NOTE

- The CT direction must be consistent with the arrow direction as shown in the preceding figure.
- The maximum torque of 3, 6, 9 and 10 terminal screws is 1.7N.m, and the recommended torque is  $(1.0 \pm 0.1)$  N.m; The maximum torque of 13, 14, 16, 17, 19, 21, 24 and 25 terminal screws is 0.4N.m, and the recommended torque is  $(0.20 \pm 0.05)$  N.m.
- 2A is recommended for FUSE in the wiring diagram.

## Three-phase three-wire connection

1. Connect the  $U_a$  and  $U_c$  voltage cables to terminals 3 and 9, and connect the  $U_b$  voltage cables to terminals 6 and 10 of the sensor.
2. Connect the current transformer  $I_a^*$  (white wire) and  $I_a$  (blue wire) for phase A to terminals 13 and 14 of the sensor; Current transformer  $I_b^*$  (white wire) and  $I_b$  (blue wire) for phase B connected to terminals 16 and 17 of the sensor; Current transformer  $I_c^*$  (white line) and  $I_c$  (blue line) for phase C connected to terminals 19 and 21 of the sensor. connected to terminals 19 and 21 of the sensor.
3. Connect RS485A and RS485B to the communication host.

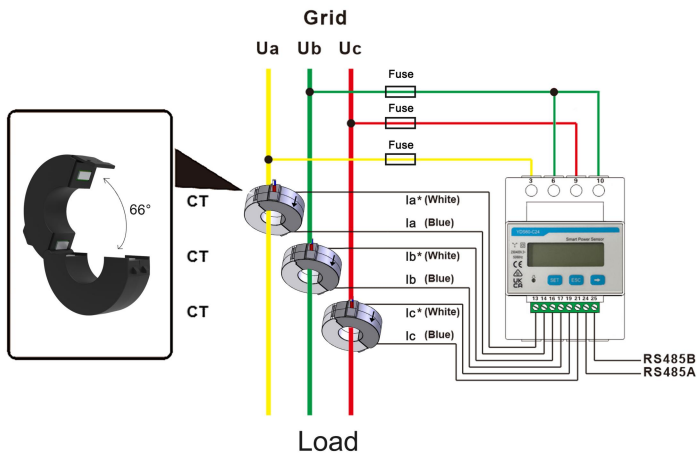

### NOTE

- The CT direction must be consistent with the arrow direction as shown in the preceding figure.
- The maximum torque of 3, 6, 9 and 10 terminal screws is 1.7N.m, and the recommended torque is  $(1.0 \pm 0.1)$  N.m; The maximum torque of 13, 14, 16, 17, 19, 21, 24 and 25 terminal screws is 0.4N.m, and the recommended torque is  $(0.20 \pm 0.05)$  N.m.
- 2A is recommended for FUSE in the wiring diagram.

## 4 User Interface

### 4.1 Model Display (Auto loop)

Auto loop per page hold time = 5s.

No.	Display interface	Description	No.	Display interface	Description
1		Imp. active energy = 10000kWh	2		Exp. active energy = 2345.67kWh
3		active power = 3.291kW	4		Phase A voltage = 220.0V
5		Phase B voltage = 220.1V	6		Phase C voltage = 220.2V
7		Phase A current = 5.000A	8		Phase B current = 5.001A
9		Phase C current = 5.002A	10		Frequency Freq = 50.00 Hz

### 4.2 Display(Key switch)

Press "ESC" or "→" to switch between the following display interfaces.

No.	Display interface	Description	No.	Display interface	Description
1		Comb. active energy = 7654.33kWh	2		Imp. active energy = 10000kWh
3		Exp. active energy = 2345.67kWh	4		None parity, 8 data bits, 1 stop bit, Baud = 9600bps (default)
5		011 represents address (default)	6		Phase A voltage = 220.0V
7		Phase B voltage = 220.1V	8		Phase C voltage = 220.2V



#### NOTE

Comb. active energy = Imp. active energy - Exp. active energy

No.	Display interface	Description	No.	Display interface	Description
9		Phase A current = 5.000A	10		Phase B current = 5.001A
11		Phase C current = 5.002A	12		Phase active power = 3.291kW
13		Phase A active power = 1.090kW	14		Phase B active power = 1.101kW
15		Phase C active power = 1.100kW	16		Power factor PFt = 0.500
17		Phase A power factor PFA = 1.000	18		Phase B power factor PFb = 0.500
19		Phase C power factor PFC = 0.500	20		Frequency Freq = 50.00 Hz

### 4.3 Parameter Settings

No.	Parameter	Value Range	Description
1		0: n.1 1: n.2 2: E.1 3: o.1 4: 645	Settings for communication stop bit and Parity bits: 0: None parity, 1 stop bit, n.1; 1: None parity, 2 stop bits, n.2; 2: Even parity, 1 stop bit, E.1; 3: Odd parity, 1 stop bit, O.1; 4: Factory mode
2		2: 4.800 3: 9.600 4: 19.20 5: 115.2	Communication baud rate: 2: 4800bps; 3: 9600bps (default); 4: 19200bps; 5: 115200bps.
3		11~19	Modbus communication address.

## 4.4 Parameter Setting Operations

Key description: "SET" represents "confirm" or "cursor shift" (when entering digits), "ESC" represents "exit", and "→" represents "add". The password is 701.

### Set communication address, check bit, and baud rate:

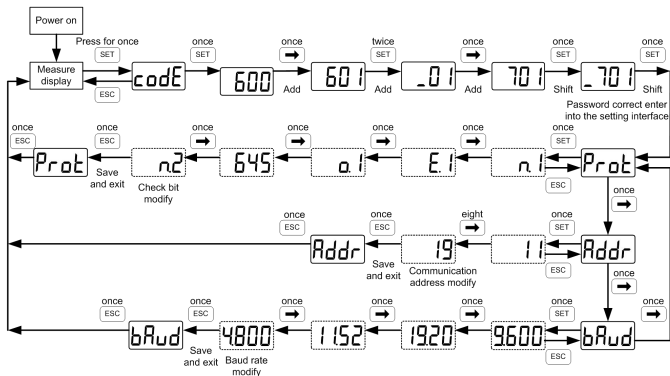

### Modify user password:

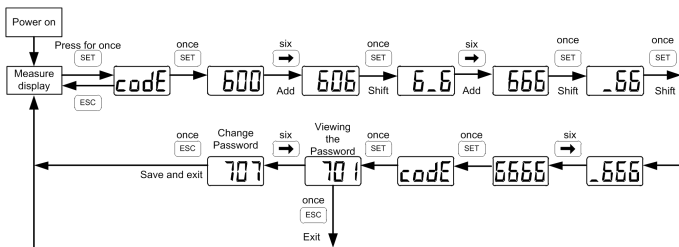

## 5 Troubleshooting

Symptom	Cause Analysis	Troubleshooting Method
No display after power-on	<ol style="list-style-type: none"><li>1. The cable connection is incorrect.</li><li>2. The voltage supplied to the meter is abnormal.</li></ol>	<ol style="list-style-type: none"><li>1. Connect the cables correctly (see wiring diagrams).</li><li>2. Supply the correct voltage based on the specifications.</li></ol>
Abnormal RS485 communication	<ol style="list-style-type: none"><li>1. The RS485 communication cable is disconnected, short-circuited, or reversely connected.</li><li>2. The communication address, baud rate, data bit, and parity bit of the meter do not match those of the inverter.</li></ol>	<ol style="list-style-type: none"><li>1. If the communication cable is faulty, replace it.</li><li>2. Set the communication address, baud rate, data bit, and parity bit of the meter to be the same as those of the inverter by pressing buttons. For details, see "Parameter Settings".</li></ol>
Inaccurate metering	<ol style="list-style-type: none"><li>1. The cable connection is incorrect. Check whether the corresponding phase sequence of voltage and current is correct.</li><li>2. Check whether the high and low ends of the current transformer inlet are reversely connected. If the values Pa, Pb, and Pc are negative, the high and low ends are connected incorrectly.</li></ol>	<ol style="list-style-type: none"><li>1. Connect the cables correctly (see wiring diagrams).</li><li>2. If a negative value is displayed, change the cable connection for the current transformer to ensure that the high and low ends are connected correctly.</li></ol>

## 6 Installation Verification

1. Check that all mounting brackets are securely installed and all screws are tightened.
2. Check that all cables are reliably connected in correct polarity without short circuit.