



NO: 13040207.0013.00

Three-phase Smart Power Sensor Instructions



Guangdong Yada Electronics Co., Ltd



Danger and warning

Before installing, operating or maintaining the equipment, please read this manual carefully, get it and gradually get familiar with the equipment. This document is not an operating manual for non-trainees, and our company are not responsible for any problems arising out of its normal use.



Risk of electric shock, fire or explosion

- There is a power hazard in some parts of this equipment. Please operate in strict accordance with the specifications.
- Before maintenance and overhaul, the equipment must be powered off and grounded.
- All mechanical parts, doors and covers should be returned to their original position before the equipment is energized.
- Equipment maintenance and installation work can only be performed by qualified personnel.

If you do not pay attention to these precautions, it may cause serious injury

Contents

Chapter I Product Introduction	1
1.1 Overview	1
1.2 The reference standard.....	1
1.3 Model specification	1
1.4 Function Description	1
1.4.1 Metering function.....	1
1.4.2 Measurement function of electrical parameters.....	2
1.4.3 Display function	2
1.4.4 Communication function	2
1.4.5 Local setting function.....	2
1.4.6 Refresh cycle	2
1.4.7 Pulse indicator	2
Chapter II Installation	3
2.1 Installation, prevention and preparation	3
2.2 Installation Information	3
2.2.1 Installation notes	3
2.2.2 Installation dimensions	3
2.2.3 Installation	5
2.2.4 Cable requirements	7
2.3 Port definition	8
2.3.1 Panel description and port definition	8
2.4 Wiring diagram	9
2.4.1 Voltage and current input wiring diagram	9
2.4.2 Communication	11
2.5 Application Scenario	11
Chapter III Use and Operation	12
3.1 Key definition	12
3.2 Display instructions	12
3.2.1 Display the functional description	12
3.2.2 Description of the data interface	12
3.2.3 Parameter setting interface	15
3.2.4 Description of key press operation	15
Chapter IV Technical indicators	18

4.1 Specifications	18
4.2 Accuracy	18
4.2.1 Measuring accuracy	18
4.2.2 Basic error of electric energy	18
4.2.3 Start-up	19
4.2.4 Shunt running	19
4.3 Use environment	19
4.3.1 Electrical parameters	19
4.3.2 Working environment conditions	19
4.4 Communication Parameter	20
4.5 Insulation class and voltage resistance	20
4.6 Electromagnetic compatibility	20
4.7 Approve	21
Chapter V Maintenance and Troubleshooting	22
5.1 Troubleshooting	22
Chapter VI Quality Assurance	23
6.1 Quality Assurance	23
6.2 The quality of limit	23

Chapter I Product Introduction

1.1 Overview

Three-phase smart power smart is a new type of intelligent intelligent power smart specially designed for distributed photovoltaic system. It integrates measurement and communication, and is mainly used for the measurement of voltage, current, power, frequency, power factor, active power and other electric parameters in electric lines. It can be networked with external devices through the RS485 communication interface. Using standard DIN35mm rail installation, structure modular design, has the advantages of small size, easy to install and easy networking.

The smart converts the voltage and current signals into the signals recognized by the MCU through the sampling circuit. The MCU calculates the signal in the sampling circuit, calculates and converts it into electric energy, power, power factor and other power quantity. Transmission to the user via communication, while saving the data in a storage circuit.

1.2 The reference standard

- ◇ EN 61326-1:2013
- ◇ IEC 61326-1:2012
- ◇ EN 61326-2-1:2013
- ◇ IEC 61326-2-1:2012
- ◇ EN 61010-1:2010
- ◇ IEC 61010-1:2010
- ◇ EN 61010-2-1:2010
- ◇ IEC 61010-2-1:2010

1.3 Model specification

Model	Function
YDS60-C24	Three-phase ac voltage, current, power, power factor, frequency real-time measurement and electric power measurement, suitable for $3 \times 220/380V$, $3 \times 230/400V$, $3 \times 380V$, $3 \times 400V$ power grid system.

1.4 Function Description

1.4.1 Metering function

- ◇ Accurately measure positive and negative active power and combined active power, the collector will not lose data after power failure.
- ◇ Combined active power = positive active power - reverse active power.
- ◇ Electrical energy measurements are shown in 7 bits with a range of 0.00 kWh to 42949.67MWh.

1.4.2 Measurement function of electrical parameters

- ◇ Can accurately measure electrical parameters, including voltage, current, frequency, power factor, power, etc.

1.4.3 Display function

- ◇ Display is divided into two ways: automatic loop display and key switch display.
- ◇ Display the backlight function, power on initially, light the backlight, when no key operation, the delay of 60 seconds (when the set to 60 seconds), close the backlight, the backlight will be lit, when no operation, 60 seconds delay, close the backlight.
- ◇ Cycle display content: positive active energy, negative active energy, active power, voltage, current, frequency.
- ◇ Total active power, forward active power, reverse active power, check / stop / wave rate, communication address, voltage, current, power, power factor and frequency.

1.4.4 Communication function

- ◇ It has a RS485 communication interface, which is electrically isolated from the internal circuit of the meter head. The RS485 communication baud rate supports 4800bps, 9600bps, 19200bps, 38400bps and 115200bps. The initial default is 9600bps.

1.4.5 Local setting function

- ◇ Real time measured values can be viewed by pressing the key to turn pages;
- ◇ The communication protocol/communication address/baud rate can be set through key operation.

1.4.6 Refresh cycle

- ◇ Fast sampling channel: active power, reactive power, power factor refresh period $\leq 75\text{ms}$;
- ◇ Ordinary sampling channel: refresh cycle of all parameters of ordinary sampling channel $\leq 200\text{ms}$.

1.4.7 Pulse indicator

- ◇ A red LED indicator light is used as an electrical energy pulse indicator.

Chapter II Installation

2.1 Installation, prevention and preparation

Before installing and operating this device, read the following information carefully and follow the following safety precautions instructions.

Danger

Danger of electric shock, explosion, or arc flash

- All power connections shall be disconnected before installation, inspection, testing or maintenance.
- There are no parts that users can overhaul. Please arrange for qualified personnel to carry out maintenance.
- Do not work alone or under dangerous conditions.
- High current passing through the conductive material can cause severe burns.
- This instrument is applicable to measurement in building facilities. For example, measurement on distribution boards, circuit breakers, wiring, including cables, bus bars, junction boxes, switches, output sockets of fixed facilities, industrial equipment and other equipment, such as standing motors permanently connected to fixed facilities. On the measurement.
- If the equipment is not used in the manner specified by the manufacturer, the protection provided by the equipment may be compromised.
- The voltage input circuit for this instrument must be connected to an appropriate safety device or circuit breaker.
- The primary side current line must be double-layer insulated cable;
- The strong and weak current circuit should not use the same cable, and the wire core should be arranged in bundles respectively. The current line of the transformer is weak current, which cannot be tied together with strong current.

Otherwise, it may cause death or serious injury!

2 2 Installation Information

2.2.1 Installation notes

- ◇ The meter should be installed in dry, clean, away from heat source and strong electromagnetic field.
- ◇ The instrument is usually installed in the switch cabinet to protect the device from oil, dirt, dust, corrosive gas or other harmful substances.
- ◇ The instrument voltage input circuit must be connected with appropriate fuse.

2.2.2 Installation dimensions

(1) Installation mode (Unit: mm, Tolerance: ± 0.5)

Overall dimensions: 72mm 100mm 66mm; DIN rail mounting dimensions: 35mm;

See the figure below for overall dimensions and installation dimensions:

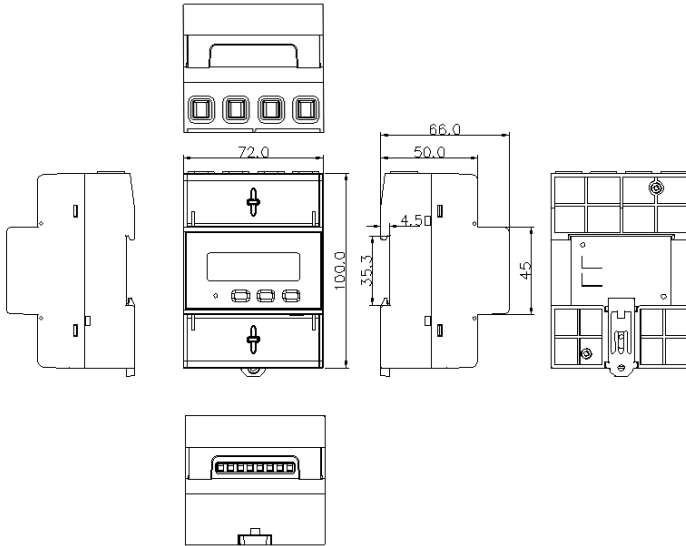

Weight: about 225g

(2) Supporting the current transformer

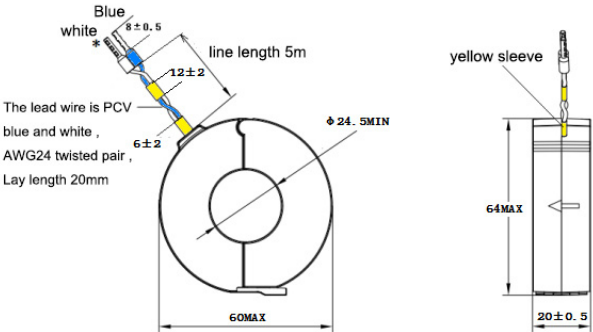
Type of transformer	product picture
SCT24L-5k-250	
Dimensions (mm)	
 <p>The lead wire is PVC blue and white , AWG24 twisted pair , Lay length 20mm</p>	
<p>Note:</p> <p>The above dimensions are for reference. please refer to our transformer specifications for more details and details.</p> <p>Each set is equipped with three transformers, which are distinguished by yellow, green and red tubes, corresponding to phases A, B and C, respectively.</p>	

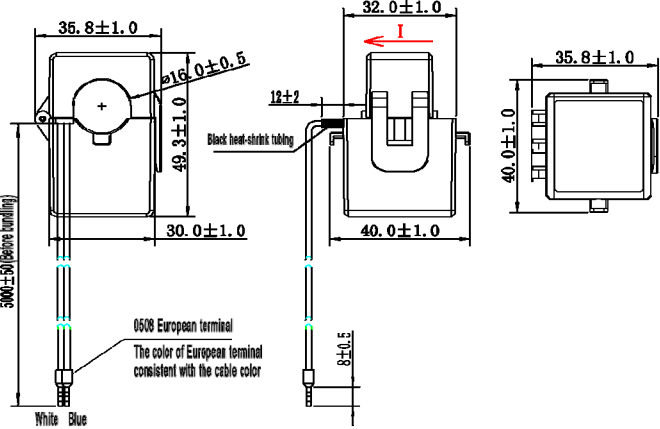
CTF16TH-2k5-100	<p>Product picture</p> 
	<p>Dimension(Unit:mm)</p>  <p>Note:</p> <p>The above dimensions are for reference. please refer to our transformer specifications for more details and details.</p> <p>Each set is equipped with three transformers, which are distinguished by yellow, green and red tubes, corresponding to phases A, B and C, respectively.</p>

2.2.3 Installation

- (1) Install the intelligent power collector onto the DIN35mm standard guide rail.
- (2) Install the smart power sensor onto the standard guide rail from top to bottom, and then push the collector into the guide rail from bottom to front.
- (3) When disassembling the machine, use a screwdriver to forcibly hold the flexible pin, and then take out the collector.



- (4) The SCT24L inter-transformer installation is shown as follows:

Transformer directly hanging on the primary current line, the tie fixed, transformer secondary output of the yellow sleeve white line

access host Ia *, blue line access the host Ia, the green sleeve white line access host Ib *, blue line access the host Ib, red casing white line access to the host Ic *, the blue line access Ic host.

Working principle of open-close type transformer

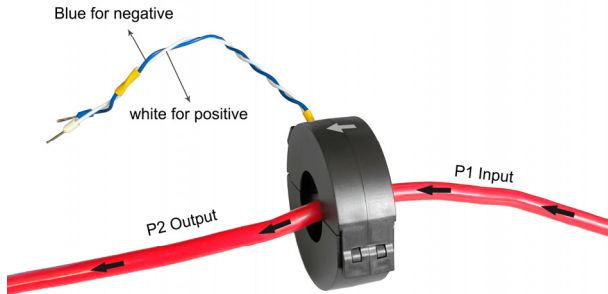

Note for disassembly and installation of open and closing transformers:

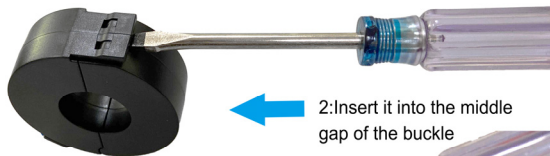

(5) The CTF16 inter-transformer installation is shown as follows:

The transformer is directly connected to the primary current line and the cable tie is fixed. The white output line on the secondary

side of the transformer is connected to I* of the host, and the blue output line is connected to I of the host.

Working principle of open-close type transformer

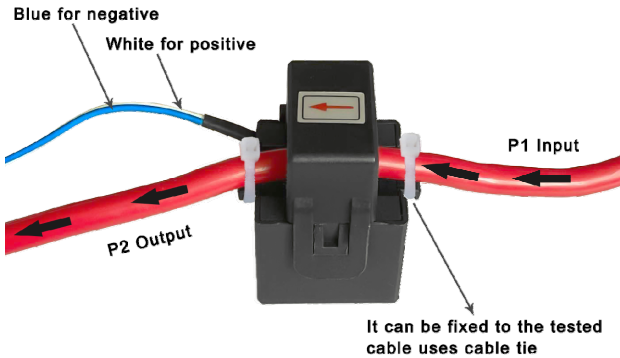

2.2.4 Cable requirements

cable	characteristic	type	Conductor section area	external diameter	Electrical performance (higher than)	source
AC voltage cable	Ua	Single-core outdoor copper-core cable	1.5mm ² ~4mm ²	3~8mm	105℃、600V	User preparation
	Ub					
	Uc					
	Un					
CT cables	Ia*	Line length of 5m with	24AWG	/	/	The transformer comes with it
	Ia	European terminal				
	Ib*	Line length of 5m with	24AWG	/	/	The transformer comes with it
	Ib	European terminal				
Ic*	Line length of 5m with	24AWG	/	/	The transformer comes with it	
Ic	European terminal					
sound cable	RS485A	Two-core outdoor	0.25mm ² ~1.5mm ²	4~11mm	80℃、300V	User preparation
	RS485B	shielding twisted-pair wire				

Note: 1. The selection of the minimum wire diameter of the cable shall comply with the local cable standards.

2. Factors affecting the selection of cables include: rated current, cable type, laying method, ambient temperature and maximum expected line loss.

2.3 Port definition

2.3.1 Panel description and port definition

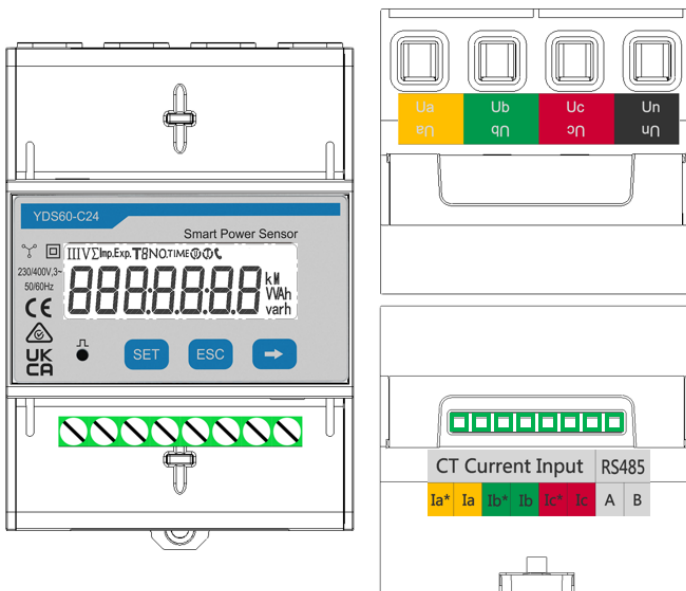

characteristic	function	description
8888888	LCD display	Display the basic data, visual window size: 47mm×14mm
	Pulse indicator light	Indicating function of electric energy pulse
	key	In display mode, press SET to enter the Settings interface. In setup mode, press SET to shift the cursor or confirm the password.
	key	In display mode, press the ESC key to go to the previous page. In setup mode, press ESC to exit to the previous level directory, or save the exit.
	key	In display mode, turn the page and go to the next page. In setting mode, set the data by adding 1.
Ua	A-phase AC voltage access	A-phase voltage line with three-phase AC
Ub	B-Phase AC voltage access	A B-phase voltage line connected to a three-phase AC current
Uc	C-phase AC voltage access	C-phase voltage line with three-phase AC
Un	N-wire connected	N-wire connected to three-phase alternating current
Ia *	A-PhaseAC current CT forward input	Connect the white terminal with the current transformer
Ia	A-PhaseAC current CT negative input	Connect to the blue terminal of the current transformer
Ib *	B-PhaseAC current CT forward input	Connect the white terminal with the current transformer
Ib	B-PhaseAC current CT negative input	Connect to the blue terminal of the current transformer
Ic *	C-phase AC current CT forward input	Connect the white terminal with the current transformer
Ic	C-phase AC current CT negative input	Connect to the blue terminal of the current transformer
A	RS485 Communications +	The RS485 communication output positive electrode
B	RS485 Communications-	The RS485 communication output negative electrode

2.4 Wiring diagram

2.4.1 Voltage and current input wiring diagram

According to different design requirements, it is recommended to add a fuse to the voltage input terminal to meet the safety requirements of the relevant electrical specifications, and the wiring diagram fuse FU recommends using 2A.

(1) With SCL24L transformer

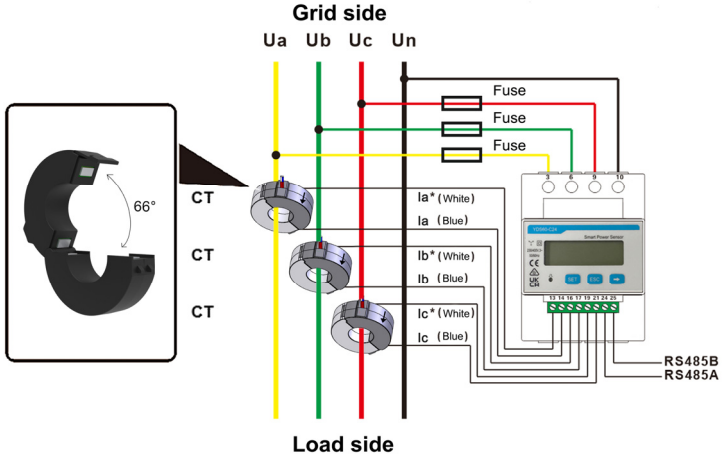

(Three-phase, three-wire wiring method)

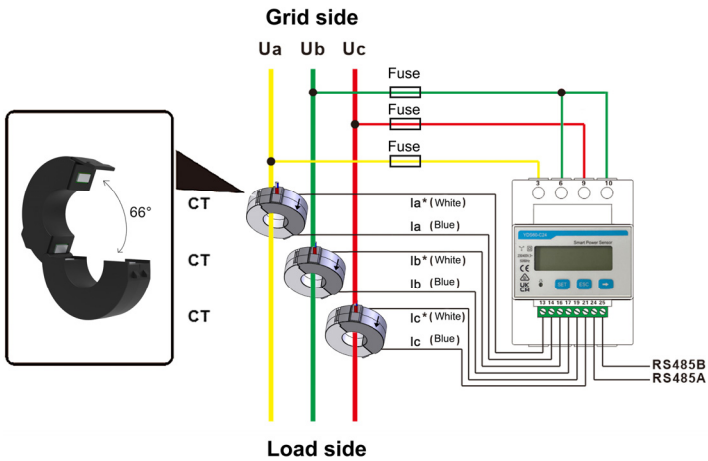

(Three-phase and three-wire wiring method)

(2)With CTF16 transformer

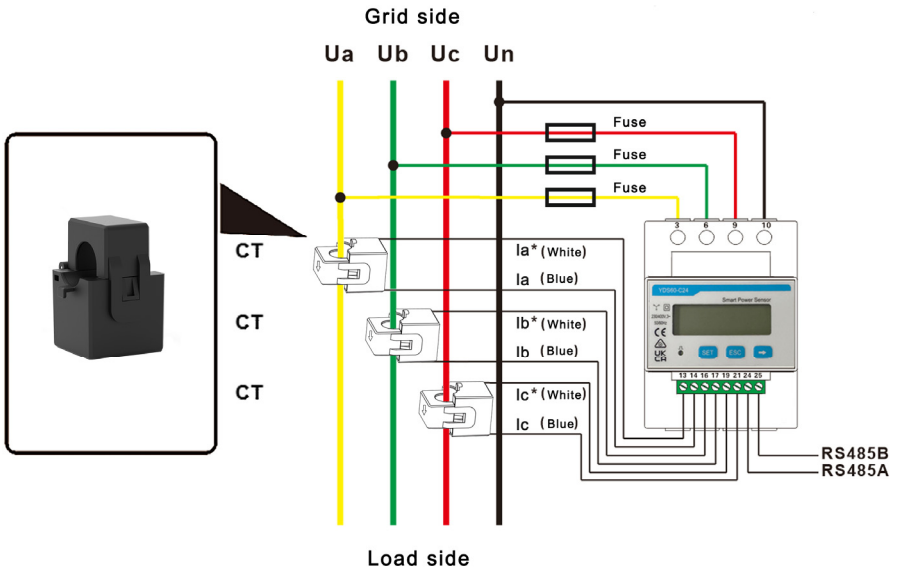

(Three-phase four-wire wiring method)

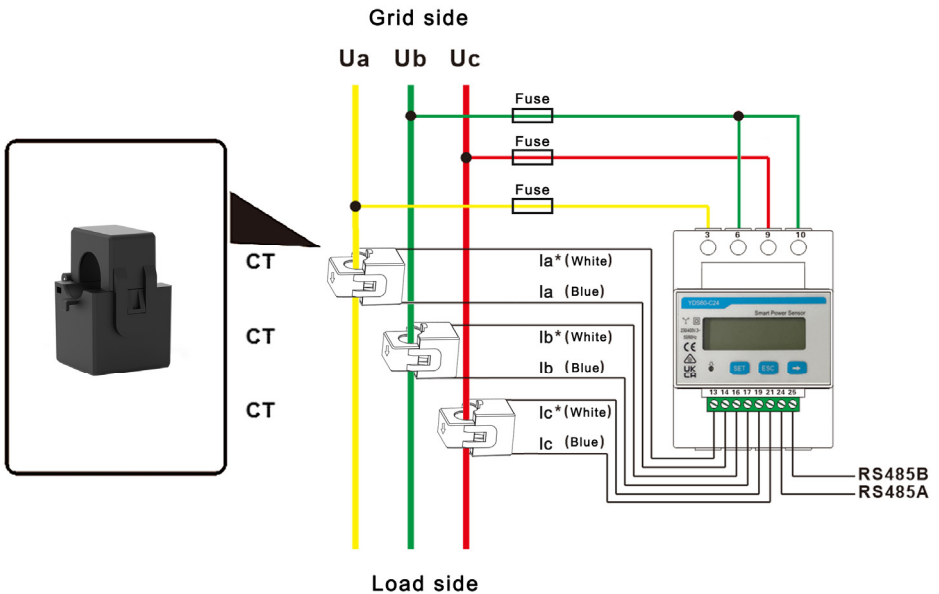

(Three-phase three-wire wiring method)

Note: the field installation of the instrument must correspond to the supporting open and closing transformer one by one, otherwise the measurement accuracy will be affected, and the connection between the two must be reliable.

2.4.2 Communication

The RS-485 communication mode allows up to 32 meters on a bus and connect to the upper computer through an RS-485 converter. The communication cable can use ordinary shielded twisted pair, the total length should not exceed 1200 meters, and the positive and negative polarity of RS-485 port of each equipment must be connected correctly. If the shielding twisted pair is long, it is recommended to have a resistance of about $120\ \Omega$ at its end to improve the reliability of the communication.

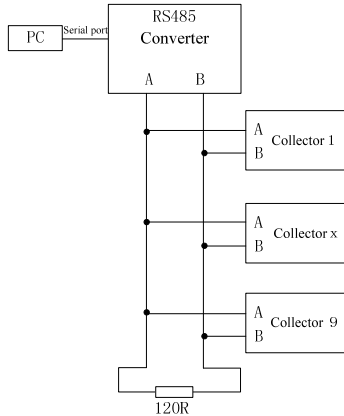

2.5 Application Scenario

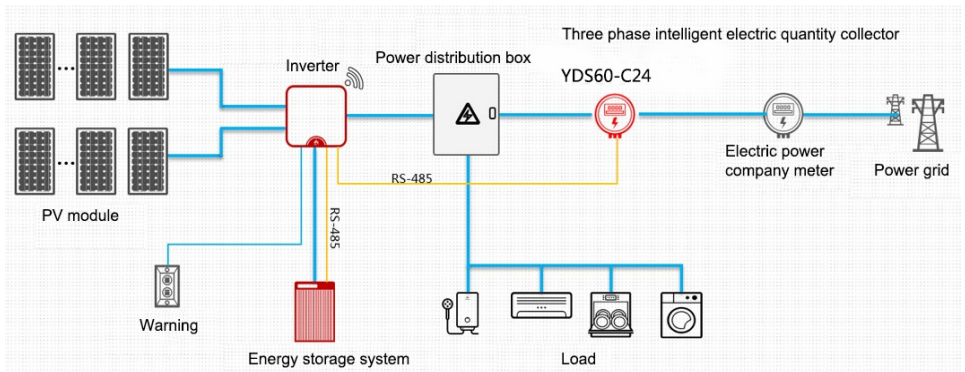

This meter is used to realize the power control of the power grid and the energy storage charge and discharge control in the household inverter scheme, and is the core component of household energy management. RS485 communication is used to realize the functions of electricity measurement and electric energy measurement, and respond to the real-time data query of the host.

The electricity meter is mainly used for the power control of the connection point. The measured power generation and electricity consumption can only be used as a reference, not as the basis of electricity metering. The electricity metering shall be subject to the metering meter of the power grid company.



Chapter III Use and Operation

3.1 Key definition

Key icon	Key name	Key function
 or "ESC"	Return key	1、 When viewing the interface, turn up the screen to display; 2、 When programming, in the parameter interface, exit the menu; 3、 When programming, in the editing interface, return to the parameter interface.
 or "→"	Left shift key	1、 When viewing the interface, turn down the screen to display; 2、 When programming, in the parameter interface, turn over the screen display; 3、 When programming, the flashing bit value increases in the editing interface.
 or "SET"	Set the key	1、 When viewing the interface, enter the parameter screen; 2、 When programming, in the parameter interface, enter the editing interface; 3、 When programming, in the editing interface, flashing digital right shift;

3.2 Display instructions

3.2.1 Display the functional description

- (1) Using segment code liquid crystal display, display mode is divided into automatic cycle display and button switch display two kinds, display items can not be set.
- (2) The display has backlight function, the backlight is white, and can be lit by the key. When there is no key operation, the delay is 60 seconds and the backlight is closed; when the key is effectively operated Will light on, after 60 seconds, turn off the backlight.
- (3) Indicator light: active electric energy pulse indication (red).
- (4) After the computer is charged, the LCD enters the full display and holds for 5 seconds, and the full display is as follows:



LCD display (full display)

3.2.2 Description of the data interface

- (1) In the automatic cycle display, the following serial number 1 to serial number 10 is automatically switched, and the residence time of each page of the automatic cycle display is fixed to 5 seconds:

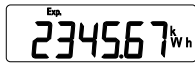
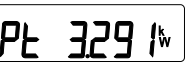
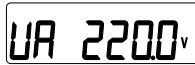
order number	Display interface	explain	order number	Display interface	explain
1		Positive active power =10000.00kWh	2		Negative active power =2345.67kWh
3		Phase closing active power =3.291kW	4		A phase voltage =220.0V

5		B phase voltage =220.1V	6		C phase voltage =220.2V
7		A phase current =5.000A	8		B phase current =5.001A
9		C phase current =5.002A	10		frequency =50.00Hz

(2) Key switch display, you can click "**→**" and "**ESC**" keys to turn the page up and down the display from serial number 1 to serial number 20. When there is no operation, the delay is 60 seconds:

Serial No.	Display interface	Explain	Serial No.	Display interface	Explain
1		Total active power =7654.33kWh	2		Positive active power =10000.00kWh
3		Reverse active power =2345.67kWh	4		No check bit, One stop Baud rate = 9,600 bps
5		Communication address =1	6		A phase voltage =220.0V
7		B phase voltage =220.1V	8		C phase voltage =220.20V
9		A phase current =5.000A	10		B phase current =5.001A
11		C phase current =5.002A	12		Joint phase active power =3.291kW
13		Phase A active power =1.090kW	14		Phase B active power =1.101kW
15		C phase active power =1.100kW	16		The phase The power factor PF t = 0.500
17		A each other power factor PFa=1.000	18		B each other power factor PFb=0.500
19		Phase C power factor PFc=0.500	20		frequency =50.00Hz

Note: If the serial number 4, the check bit, the stop bit and the port rate are changed through the protocol or the key, 16 different interfaces will appear, detailed as follows:

order number	Display interface	meaning	order number	Display interface	meaning
1		No check, 1 stop bit, port rate 4800	9		No check, 2 stop bits, port rate 4800
2		No check, 1 stop bit, port rate 9600	10		No check, 2 stop bits, port rate 9600
3		No check, 1 stop bit, port rate 19200	11		No check, 2 stop bits, baud rate 19200
4		No check, 1 stop bit, port rate 115200	12		No check, 2 stop bits, port rate 115200
5		Even check, 1 stop bit, port rate 4800	13		Odd check, 1 stop bit, baud rate 4800
6		Even check, 1 stop bit, baud rate 9600	14		Odd check, 1 stop bit, baud rate 9600
7		Even check, 1 stop bit, port rate 19200	15		Odd check, 1 stop bit, baud rate 19200
8		Even check, 1 stop bit, port rate 115200	16		Odd check, 1 stop bit, baud rate 115200

(3) Display resolution and display range

order number	Displays the project	resolution ratio	indication range	Show examples	remarks
1	voltage (V)	0.1	100.0~999.9		Phase A voltage =220V
2	current (A)	0.001	0.000~9.999		Phase A current =5.000A
		0.01	10.00~99.99		Phase A current =50.00A
		0.1	100.0~999.9		Phase A current =250.0A
3	power (W)	0.001	0.0~9.999		Phase A power =8.8W
		0.01	10.0~99.99		Phase A power =88W
		0.1	100.0~999.9		Phase A power =888W
	power (kW)	0.001	1000~9999		Phase A power =1.090kW
		0.01	10000~99999		Phase A power =11.00kW
4	power factor	0.001	-1.000~0.000		C-phase power factor =0.500C
			0.000~1.000		Phase A power factor =1.000L
5	frequency (Hz)	0.01	45~65Hz		Frequency =50.00Hz

6	Total active electric energy (kWh)	0.01	0.00~99999.99	/	Automatic switch decimal places, automatically switch units
		0.1	100000.0~999999.9	/	
		1	1000000~9999999	/	
Total active electric energy (MWh)	0.01	10000.00~42949.67	/		
7	Forward active electric energy (kWh)	0.01	0~42949672.95	/	
8	Reverse active electric energy (kWh)	0.01	0.00~99999.99		
		0.1	100000.0~999999.9		
		1	1000000~9999999		
	Reverse active electric energy (MWh)	0.01	10000.00~42949.67	/	

3.2.3 Parameter setting interface

Press the "SET" button to enter the setting interface. The Settings menu instructions are shown below:

order number	Display interface	meaning	Can set the scope	Factory default
1		Set up the communication protocol, check bits, and stop bits.	0: n.1; No check, 1-bit stop bit 1: n.2; No check, 2-bit stop bits 2: E.1; even check, 1-bit stop bit 3: o.1; odd check, 1-bit stop bit 4;645; reserved	n.1
2		mailing address	11-19	11
3		Paud rate (last four)	2: 4.800 3: 9.600 (by default) 4: 19.20 5: 115.2	9.600
pour	① The setting range of the correspondence address is 11-19. If the setting value is value outside this range, it will not be saved successfully. ② Paud rate, you can only choose 4.800,9.600,19.20,115.2.			

3.2.4 Description of key press operation

By combining the keys on the three panels, the local parameter configuration, see the key description and interface definition> <2.3.1 panel, setting idea is to enter the parameter selection interface, find the parameters to set, and then modify the setting, the following five parts of the key operation, the first part into the operation, the interface of the parameter configuration process, and the operation process of viewing and changing the password.

(1) The operation process for entering the configuration page is as follows (the default user password is 701):

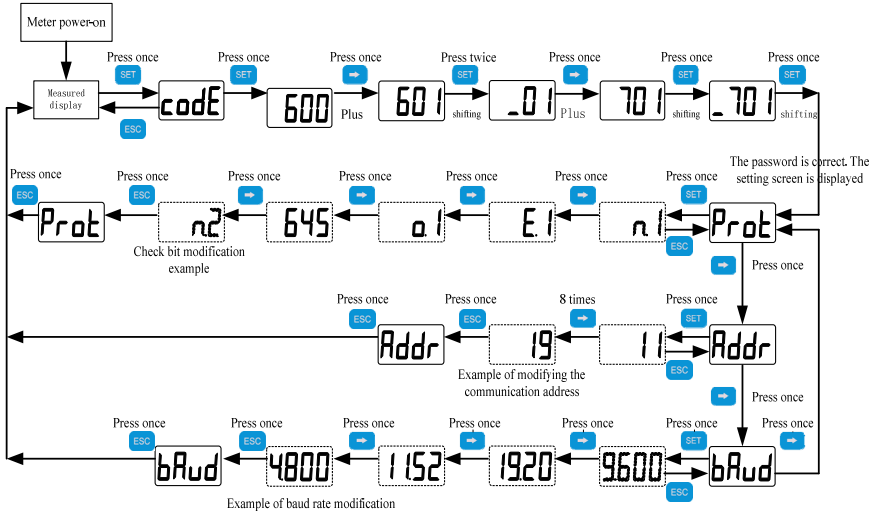

Note: ① The dotted line box in the figure above is the editing page. After entering this page, press the "1" **ESC** key to return to the setting interface, and **ESC** the key in the setting interface will return to [Measurement value display] See below (2), (3), (4) for more detailed operation of the page; ② In the process of user password input, you can directly return to [measurement value display] by pressing the button **ESC**.

(2) The settings of the communication protocol 645 (reserved), check bit and stop bit are illustrated as follows:

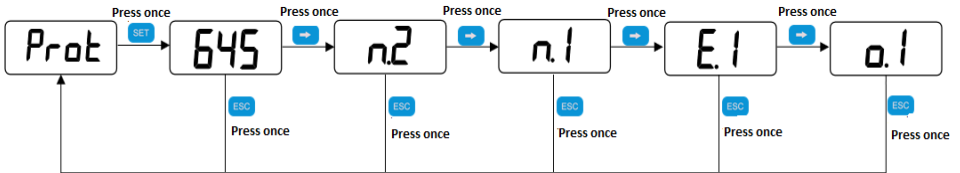

Note: Edit through the **ESC** key, and then press the **ESC** key to save the return setting interface.

(3) The setting of the correspondence address is illustrated as follows:

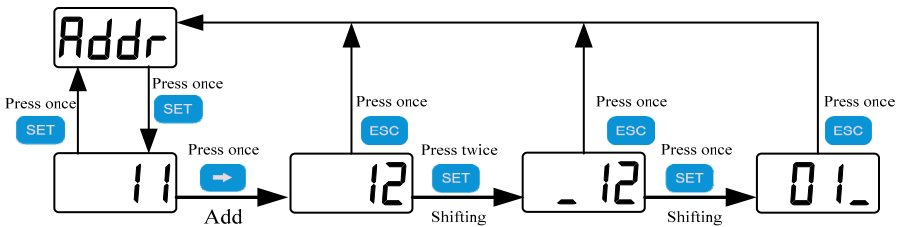

Note: The range of the correspondence address is 11-19.

(4) The setting of the baud rate is illustrated as follows:

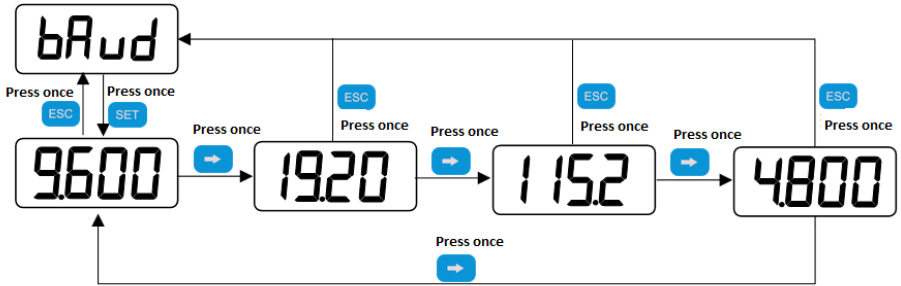

Note: The default port rate is 9600.

(5) View and modification of user password:

The default user password is 701. You can view and change the user password (to 707) by entering the super password 6666 before entering the configuration interface. The following is the key operation process

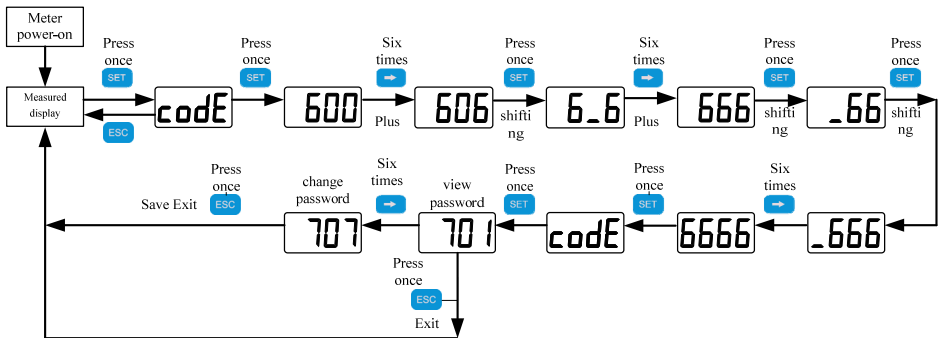

Note: ① In the above steps, the key **ESC** in the process of entering the password will be directly returned to the "measurement value display" interface

② The password modification range is 1-999. If the value entered when setting the password is beyond this range, the exit will not be saved.

Chapter IV Technical indicators

4.1 Specifications

Item	Specifications 1	Specification 2
Reference voltage (Un)	3×230/400V	3×230/400V
Reference current Ib (Imax)	3×250(300)A	3×100(120)A
Accuracy of active power	1 Class	1 Class
Electric energy pulse constant	200imp/kWh	400imp/kWh

4.2 Accuracy

4.2.1 Measuring accuracy

Item	Index	measuring range
Current	±0.5%	0.11 b ≤I<Imax
	±1%	0.051 b ≤I<0.11 b
Phase voltage	±0.5%	176V ~288V
line voltage	±0.5%	304V~500V
Active power	±1%	0.11 b ≤I<Imax
	±1.5%	0.051 b ≤I<0.11 b
Frequency	±0.02Hz	45Hz~65Hz
Power factor	±0.01	-1~0~1
Active power	1 Class	See 4.2.2 Basic error of electric energy for details
Reactive power	2 Class	/

4.2.2 Basic error of electric energy

Table 1 Limit value of active power percentage error of the electricity meter during balancing load

Class	Current range	Power factor	The percentage error limit of the instrument of each level is (%)		
			0.5S Class	1 Class	2Class
Direct access	0.051 b ≤I<0.11 b	1	-	±1.5	±2.0
	0.11 b ≤I≤Imax	1	-	±1.0	±1.5
	0.11 b ≤I<0.21 b	0.5L、0.8C	-	±1.5	±2.5
	0.21 b ≤I≤Imax	0.5L、0.8C	-	±1.0	±2.0
Remarks	In: refers to the secondary rated current of the current transformer; Ib: refers to the calibration current of the electric energy meter; L: Sensibility; C: Capacitive				

Table 2 Limit value of reactive percentage error of electric-hour meter during balancing load

Current value	Sinφ (Emotional or accommodating)	The percentage error limit of the instrument of each level is (%)
Direct access to the meter		2
0.051 b ≤I<0.11 b	1	±2.5
0.11 b ≤I≤Imax	1	±2.0
0.11 b ≤I<0.21 b	0.5	±2.5
0.21 b ≤I≤Imax	0.5	±2.0
0.21 b ≤I≤Imax	0.25	±2.5

Table 3 Limit value of active power percentage error of electricity meters during unbalanced load

Current value	Sinp(Emotional or accommodating)	The percentage error limit of the instrument of each level is (%)		
		0.5S	1	2
Direct access to the instrument				
$0.11 b \leq I \leq I_{max}$	1	±0.6	±2.0	±3.0
$0.21 b \leq I \leq I_{max}$	0.5L	±1.0	±2.0	±3.0

Table 4 Limit value of reactive power percentage error of the watt-hour meter during unbalanced load

current value	Sinp(Emotional or accommodating)	The percentage error limit of the instrument of each level is (%)	
		2	
Direct access to the instrument			
$0.11 b \leq I \leq I_{max}$	1		±3.0
$0.21 b \leq I \leq I_{max}$	0.5		±3.0

4.2.3 Start-up

According to the reference voltage and 4.1 specification, the collector starts and continuously measures electric energy.

Collector	Meter class	Power factor
	I Class	
Direct connection	0.004Ib	1

4.2.4 Shunt running

When 115% U_n is applied and the current line has no current, the collector shall not generate more than one pulse within the shortest time of Δt .

$$\Delta t \geq \frac{600 \times 10^6}{K \cdot m \cdot U_n \cdot I_{max}} \quad [\text{min}]$$

The shortest amount of Δt is:

Where: k—pulse constant (imp / kWh), m—number of measuring elements, U_n —reference voltage (V), I_{max} —maximum current (A)

4.3 Use environment

4.3.1 Electrical parameters

Item	Index	Item	Index
Working voltage range	90VAC~500VAC	Measurement category	CAT-III-230
Overvoltage category	III	Power power consumption	≤1.5W
Working frequency	45Hz~65Hz	/	/

4.3.2 Working environment conditions

Item	Index	Item	Index
Working temperature range	-25℃~60℃	Extreme operating temperature range	-35℃~70℃
Storage and transport temperature range	-40℃~85℃	Work relative humidity	5%~95% (no condensation exposure)
class of pollution	2	height	≤2000m
Barometric pressure	86kPa ~106kPa	levels of protection	Panel IP51, the complete machine is IP20

4.4 Communication Parameter

Item	Parameter	Item	Parameter
Communication port	RS-485 (Double line), isolated communication	check bit	No / odd / even available, Factory by default without verification
Communication address	11~19 (factory default 11)	data bit	8bits
Baud rate	4800/9600/19200/115200 (Factory default 9600bps)	stop bit	1bits or 2bits
Communication statute	The ModBus-RTU specification	Data upload	Data communication was performed by the standard ModBus protocol
Communication interval	Two command sending interval>10ms	Communication response time	≤50ms

4.5 Insulation class and voltage resistance

Item	Index
levels of protection	II
Power frequency withstand voltage	Voltage input to RS485 communication: 3.51kV · min · mA
Impulse withstand voltage	Voltage input to RS485 communication: 6kV-1.2/50us.4

4.6 Electromagnetic compatibility

Item	Index	satisfied
RE (Radiated emission)	CLASS B (-6dB) @30MHz~6GHz	—
RS (Radiated immunity)	Power on : 10V/m、80%AM(1KHz)、80~6000MHz	Criterion A
	No power input : 30V/m、80%AM(1KHz)、80~6000MHz	Criterion A
CE (Conducted emission)	CLASS B (-6dB) @150kHz~30MHz	—
CS (Immunity to conducted disturbances)	10V、80%AM(1kHz)、0.15~80MHz	Criterion A
SURGE (surge immunity), impulse current	Protection grade of RS485 communication port: surge differential mode 4KV (internal resistance 42 Ω, 1.2/50us)	—
	Surge from RS485 communication port to AC power port is 4KV; (485 signal lines are connected together and AC input lines are connected together for verification)	—
	Power port: surge differential mode 4KV	—
EFT (Electrical Fast Transient Burst Immunity)	±4kV、5/50ns、5kHz	Criterion B
AC-DIP (voltage sag, short interruption, voltage change immunity)	Drop to 0%UT, Time for 10ms	Criterion B
	Drop to 0%UT, Time for 20ms	Criterion B
	Drop to 70%UT, Time for 500ms	Criterion B
	Drop to 0%UT, Time fo 5000ms	Criterion C
Fluctuations and Flicker (Voltage fluctuation and flicker)	Pst value is not greater than 1	
	Pst value is not greater than 0.65	
	The relative voltage change dc shall not exceed 3.3%	
	The maximum relative voltage change dmax shall not exceed 4%	
	The time when d (t) value exceeds 3.3% during voltage change shall not exceed 500ms	
Harmonic(Current harmonic of power supply port)	50—2000Hz,Requirements for Class A products	—

ESD (electrostatic discharge immunity)	Contact discharge 6KV; Air discharge 8KV	Criterion B
PMS specification (Power frequency magnetic field immunity)	The PMS index of unit shell port shall meet the requirements of IEC61000-4-8 standard.The specific requirements are system index - steady state: 30A/m, 1 minute test;	Criterion B
<p>General criteria:</p> <p>A: During the test, the connection established can be maintained.</p> <p>B: During the test, the performance of the equipment may be reduced within the range required by the product specification.After the interference is eliminated, the equipment can return to normal, and no reset or manual intervention in any way is allowed.</p> <p>C: A temporary loss or reduction in function or performance that requires manual intervention to return to normal.</p>		

4.7 Approve

Item	Index
Approve	CE、UKCA、RCM

Chapter V Maintenance and Troubleshooting

5.1 Troubleshooting

Possible problems	Possible cause	Possible solution
No display after power-on	1.Wrong wiring mode.	1.If the wiring method is incorrect, please conduct wiring according to the correct wiring method (see the wiring diagram).
	2.The power supply voltage is abnormal.	2. If the power supply voltage is abnormal, please provide the voltage according to the collector specification.
RS485 communication exception	1.RS485 communication line is not connected, short circuited or reversed.	1.If there is a problem with the communication cable, please replace the cable.
	2.The communication address, baud rate, data bit and check bit are inconsistent with the host.	2. Press the key to set the communication address, baud rate, data bit and check bit consistent with the host.See "Parameter Setting" for key setting operation.
Inaccurate electric energy measurement	1.Wiring error, check whether the phase sequence corresponding to voltage and current is correct.	If the wiring method is not correct, please follow the correct wiring method (see the wiring diagram).
	2.Check whether the high end and low end of the current transformer incoming line are connected reversely.	

Note: If there are some problems that cannot be solved, please contact our after-sales service department in time.

Chapter VI Quality Assurance

6.1 Quality Assurance

All new meters sold to customers shall be provided with free quality assurance for the faults caused by design, materials and process within 12 months after power-on or 18 months after receiving the goods. If the products are determined to meet the above quality guarantee conditions, our company shall be responsible for free maintenance.

6.2 The quality of limit

Problems with the following devices are not covered by free warranty:

- Damage due to incorrect installation, use, and storage.
- Excessive operating and application conditions beyond the product specifications.
- The meter that has been repaired by an organization or person that is not authorized by the company.
- The meter that exceeds the free warranty period.

Note: The above pictures are for reference only, the products are subject to the actual product.



Guangdong Yada Electronics Co.,Ltd.

Address:Yada industry park, Gaopugang, Heyuan city,
Guangdong Province.

Domestic market: 86-762-3493871 3493872 3493873

International market: 86-762-3496222

Technical support: 86-762-3493926 3493989 (400-830-0868)

Fax: 86-762-3493912 3493830

Zip code : 517000

[http: //www.yada.com.cn](http://www.yada.com.cn)

E-mail: market@yada.com.cn

Copyright, all rights reserved.Specification subject to change without prior notice.