



NO: 13040503.0021.00

DCM3366D-J-G 电子式直流电能表
DCM3366D-J-G Electronic DC Energy Meter

说明书
Instruction

广东雅达电子股份有限公司
Guangdong Yada Electronics Co.,Ltd



危險和警告

在进行安装、操作或者维护此设备之前，请仔细阅读本手册，拿到它并逐步熟悉设备。本文件不是一本适用于未受训者的操作手册，在其正常使用范围之外所引起的问题，本公司概不负责。



Danger and warning

Before installing, operating or maintaining the equipment, please read this manual carefully, get it and gradually get familiar with the equipment. This document is not an operating manual for non-trainees, and our company are not responsible for any problems arising out of its normal use.



触电、燃烧或者爆炸的危险

- 本设备部分存在电力危险，请严格按照规范进行作业。
- 在维护和检修之前，设备必须断电并接地。
- 在设备通电前，应将所有的机械部件，门和盖子等恢复原位。
- 设备维护和安装工作只能由有资质的人员执行。



Risk of electric shock, fire or explosion

- There is a power hazard in some parts of this equipment. Please operate in strict accordance with the specifications.
- Before maintenance and overhaul, the equipment must be powered off and grounded.
- All mechanical parts, doors and covers should be returned to their original position before the equipment is energized.
- Equipment maintenance and installation work can only be performed by qualified personnel.

若不注意这些预防措施可能会引起严重伤害。

If you do not pay attention to these precautions, it may cause serious injury.

目 录 Contents

第一章 产品介绍 Chapter I Introduction	1
1.1 概述 General	1
1.2 相关技术标准 The technical standards.....	1
1.3 型号说明 Model Description	1
1.4 功能介绍 Main function	1
第二章 安装 Chapter II Installation	3
2.1 安装预防、准备 Installation prevention, preparation.....	3
2.2 安装信息 Installation Information	3
2.2.1 安装注意事项 Installation notes.....	3
2.2.2 安装尺寸：导轨安装 Installation dimensions: Installation of guide rail	4
2.3 端子定义 Terminal definition	4
2.4 接线图纸 Wiring drawing.....	5
2.4.1 电源 Power supply	5
2.4.2 电压电流 Voltage and Current	5
2.4.3 通讯 Communication	5
第三章 使用与操作 Chapter III use and operation	7
3.1 键盘定义 Keys definition.....	7
3.2 显示说明 Display.....	7
3.2.1 显示功能说明 Display definition	7
3.2.2 数据画面说明 Description of data screen.....	8
3.2.3 参数设置画面 Parameter setting	9
第四章 技术指标 Chapter IV Technical indicators	11
4.1 规格 specifications.....	11
4.1.1 脉冲常数与功率对照表 The table of pulse constant and power	11
4.2 技术参数 Technical parameter	11
4.2.1 基本误差 Basic error	11
4.2.2 潜动 Shunting	12
4.2.3 功率消耗 Power consumption	12
4.2.4 工作环境条件 Working conditions.....	12
4.2.5 通讯参数 Communication parameters	12
4.2.6 电磁兼容 Electromagnetic compatibility.....	13
第五章 维护和故障排除 Chapter V maintenance and troubleshooting	14
5.1 故障排除 Troubleshooting	14
第六章 质量保证 Chapter VI Quality Assurance	15
6.1 质量保证 Quality Assurance	15
6.2 质量限制 The quality of limit	15

第一章 产品介绍 Chapter 1 Introduction

1.1 概述 General

DCM3366D系列电子式直流电能表是我公司生产的新一代产品。采用液晶显示，具有RS485通讯功能可与微机进行数据交换。适合蓄电池，太阳能电池板等直流信号设备电量测量和电能计量使用，亦可用于工矿企业，民用建筑，楼宇自动化等现代供配直流电系统。

由测量单元、数据处理单元、通讯单元、显示单元等组成，具有电能计量、数据处理、实时监测、LCD显示功能。电能表具有高倍过载、高精度、低功耗、停电数据自动保存、长寿命等特点。

DCM3366D Series Electronic DC energy meter is a new type product of our company which adopts LCD display and RS485 communication with the microcomputer. It is suitable to be used for batteries, solar panels power DC signal measurement and energy metering equipment. It also can be used for industrial and mining enterprises, civil construction, building automation and other modern DC system for distribution.

It consists of measurement unit, data processing unit, communication unit, display unit, etc., with power measurement, data processing, real-time monitoring, LCD display function. The energy meter has the characteristics of high power overload, high accuracy, low power consumption, automatic saving of power failure data and long life.

1.2 相关技术标准 The technical standards

Q/GDW 1825-2013 《直流电能表技术规范》

Q/GDW 1825-2013 《Technical specification for dc power meter》

GB/T29318-2012 《电动汽车非车载充电电能计量》

GB/T29318-2012 《Electric vehicle non-board charging energy measurement》

Q/GDW 364-2009 《单相智能电能表技术规范》

Q/GDW 364-2009 《Technical specification for single-phase intelligent electricity meters》

JJG 842—1993 《直流电能表检定条件》

JJG 842—1993 《Electronic DC Energy Meter》

1.3 型号说明 Model Description

型号 Model	功能 Function
DCM3366D-J-G	单路直流测量、复费率、一路电能脉冲输出、一路秒脉冲输出 Single DC measurement, multiple rate, one way pulse output, one way second pulse output

1.4 功能介绍 Main function

◇ 正反向电能计量，组合=正向+反向；

Forward and reverse electric energy measurement, forward = forward + reverse;

- ✧ 电压、电流、功率测量；
Measure voltage, current and power;
- ✧ 上 12 个月结算电能；
Settlement of electricity in the last 12 months;
- ✧ 具有日历、计时和闰年自动切换功能，具有校时功能。其中广播校时的时钟误差不得大于 5 分钟，在零点前后十分钟内不准校时，每天只允许校时一次；
with calendar, timing, and leap year automatic switching function, has the timing function . The clock error of the broadcasting time shall be no more than 5 minutes, and it is not allowed to be checked within 10 minutes before or after zero. Only one timing is allowed per day;
- ✧ 具有两套费率时段，可通过预先设置的时间实现两套费率时段的自动切换，每套费率时段全年至少可设 2 个时区，24 小时内至少可设 8 个时段，时段最小间隔为 15 分钟，时段可跨零点设置；
There are two sets of rate periods, which can be automatically switched through the preset time. Each rate period can be set at least 2 time zones, and at least 8 time zones can be set within 24 hours, with the minimum interval of 15 minutes, and the time period can be set across zero;
- ✧ 具有最近 10 次的编程记录和最近 10 次的校时记录；
Has the last 10 times of programming record and the last 10 times of timing record;
- ✧ 调制红外通讯接口和 RS-485 通讯接口，采用 DL/T645-2007 通讯协议和 Modbus (RTU 格式) 协议，RS485 的通讯速率可在 1200bps、2400bps、4800bps、9600bps 设置，调制红外的通讯速率固定为 1200bps。
Modulation infrared communication interface and RS-485 communication interface, using DL/T645-2007 communication protocol and Modbus (RTU format) protocol, RS485 communication rate can be set at 1200bps, 2400bps, 4800bps, 9600bps, modulation infrared transmission rate is fixed at 1200bps.

第二章 安装 Chapter II Installation

2.1 安装预防、准备 Installation prevention, preparation

请在开始操作前阅读 Please read before starting the installation

本章包含重要的安全预防信息，在安装、服务或维护电气设备前必须遵守这些指导。仔细阅读并遵循下列安全预防指导。This chapter contains important safety precautions that you must follow before installing, servicing, or servicing electrical equipment. Read and follow the following safety precautions carefully.



电击，烧毁或爆炸的危险，所以只有合格的操作人员才能安装本设备。此工作应在阅读了该全部指导后开展。在进行安装，检验，测试或维护前，应断开所有的电源连接。请依照说明书中的接线说明接线，接完后要认真核对接线是否正确无误。意识到潜在的危险，工作人员需佩戴保护设备，仔细检查工作接线和安装是否正确。安装或者拆除仪表时，请确认电源、待测信号源及相关电源是否完全断开。



The danger of electric shock, fire or explosion, so that only qualified personnel can install the equipment. This work should be carried out after reading all of this guidance. In the visual inspection, testing or maintenance, should disconnect all power connection. Please follow the wiring instructions in the instructions and carefully check if the wiring is correct. Aware of the potential danger, workers need to wear protective equipment and carefully check the wiring and installation is correct. When installing or removing the meter, make sure the power supply, signal source to be measured and related power supply are completely disconnected.

2.2 安装信息 Installation Information

2.2.1 安装注意事项 Installation notes

- ◇ 仪表应安装在干燥、清洁、远离热源和强电磁场的地方。
The meter should be installed in dry, clean, away from heat and strong electromagnetic fields.
- ◇ 仪表位置通常安装在开关柜中，可使装置不受油、污物、灰尘、腐蚀性气体或其他有害物质的侵袭。
The meter location is usually installed in the switch cabinet, which can protect the device from oil, dirt, dust, corrosive gas or other harmful substances.
- ◇ 安装时要注意检修方便，有足够的空间放置有关的线、端子排、短接板和其他必要的设备。
During installation, please pay attention to the convenience of maintenance. There is enough space to place the relevant lines, terminal blocks, short boards and other necessary equipment.
- ◇ 直流分流器mv信号输出连接线建议采用1.5mm²屏蔽双绞线，分流器与仪表接线距离不宜过长，建议线长在1米以内；电压输入线、电源线用1.5mm²多股阻燃铜线；RS-485通信用1.0mm²屏蔽双绞线。
The mv-signal output connector of dc shunt is recommended to use 1.5mm² squared shielded twisted pair, The connection distance between the shunt and the meter should not be too long. It is recommended that the line length should be less than 1m. 1.5mm² multi-strand flame-retardant copper wire for voltage input line and power line; 1.0mm² shielded twisted pair for RS-485 communication.
- ◇ 仪表电压输入回路必须接入合适的保险丝。
The meter voltage input circuit must be connected to the suitable fuse.

2.2.2 安装尺寸：导轨安装 Installation dimensions: Installation of guide rail

单位：mm Units: mm
公差：±0.5 Tolerance: ±0.5

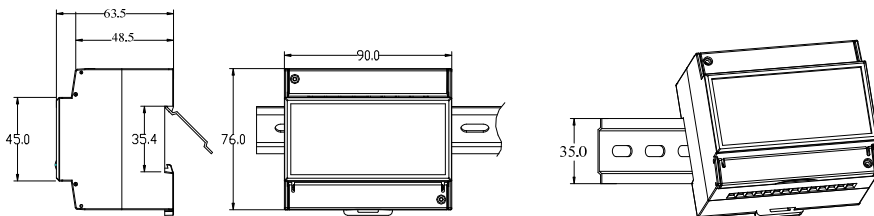

外形尺寸：长*宽*高 (90.0)mm*(76.0)mm*(63.5)mm 不包含接线端子

长*宽*高(90.0)mm*(95.5)mm*(63.5)mm 包含接线端子

Overall dimensions: (L)*(W)*(H) (90.0)mm*(76.0)mm*(63.5)mm It does not include terminals

(L)*(W)*(H) (90.0)mm*(95.5)mm*(63.5)mm Including terminals

重量：约 0.28kg

Weigh: About 0.28kg

2.3 端子定义 Terminal definition

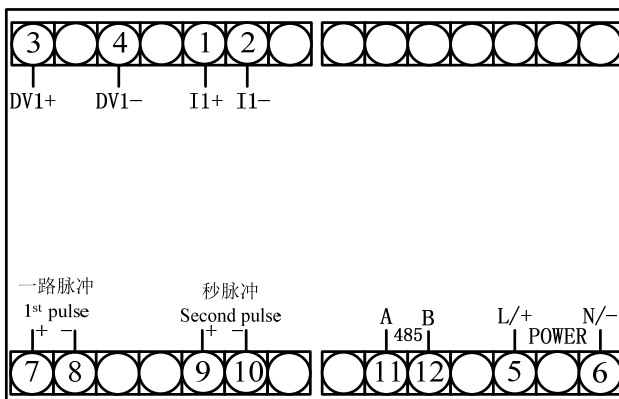

端子号 Terminal NO	端子定义 Terminal definition	注释 Remark	端子号 Terminal NO	端子定义 Terminal definition	注释 Remark
3	DV1+	第一路电压输入正极 1 st positive voltage input	9	秒脉冲+ Second pulse+	秒脉冲输出正极 The positive of pulse per second
4	DV1-	第一路电压、输入负极 The 1 st negative voltage input	10	秒脉冲- Second pulse-	秒脉冲输出负极 The negative of pulse per second
1	I1+	第一路电流输入正极 The 1 st positive current input	11	A	RS485 输出口 RS485 output port
2	I1-	第一路电流输入负极 The 1 st negative current input	12	B	

7	一路脉冲+ 1 st pulse+	第一路脉冲输出正级 The 1 st positive pulse output	5	L/+	工作电源 Power supply
8	一路脉冲- 1 st pulse-	第一路脉冲输出负级 The 1 st negative pulse output	6	N/-	

注：具体端子定义按实际型号相应增减。

Note: The specific terminal definitions are increased or decreased according to the actual model.

2.4 接线图纸 Wiring drawing

2.4.1 电源 Power supply

用于交流系统时，相线接L/+端，中性线接N/-端。电源范围AC40~265V，50Hz/60Hz。

When used in AC system, the phase line is connected to the L/+ terminal, and the neutral line is connected to the N/- terminal.

Power supply range AC40~265V, 50Hz/60Hz.

用于直流系统时，正极接 L/+端，负极接 N/-端。电源范围 DC12V(±10%)、DC9~60V、DC20~60V、DC40~330V，具体参照铭牌标注信息。

When used in DC systems, the positive terminal is connected with L/+ terminal and the negative terminal is connected with N/-terminal. Power supply range is DC12V(±10%), DC9~60V, DC20~60V, DC40~330V, refer to the information marked on the nameplate.

2.4.2 电压电流 Voltage and Current

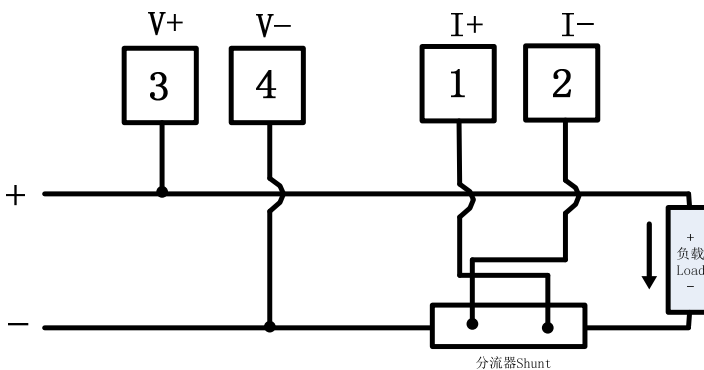

2.4.3 通讯 Communication

RS-485通信口，端子标记为A、B。

RS-485 communication port, the terminals are marked A and B.

RS-485 通信方式允许一条总线上最多接 32 台 DCM 系列仪表，通过一个 RS-485 转换器与上位机连接。通信电缆可以采用普通的屏蔽双绞线，总长度不宜超过 1200 米，各个设备的 RS-485 口正负极性必须连接正确。如果屏蔽双绞线较



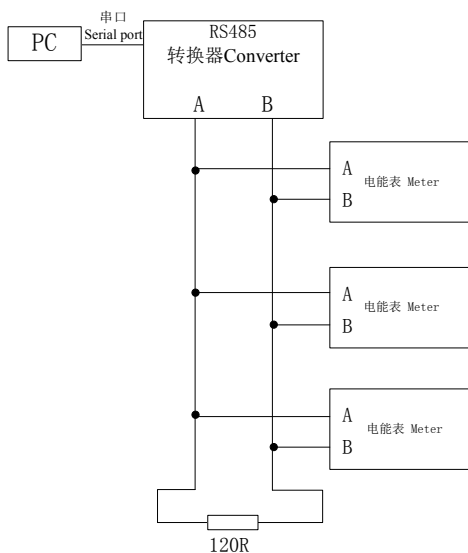

长，建议在其末端接一个约 120Ω 的电阻以提高通信的可靠性。

The RS-485 communication mode allows up to 32 DCM series energy meters to be connected to one bus, and is connected to the host computer through an RS-485 converter. Communication cable can adopt ordinary screened twisted pair, and the total length shall be no more than 1200 meters, all RS-485 ports of positive and negative polarity must be connected correctly. If shielded twisted-pair cable is longer, Suggestions on its end by one of about 120Ω resistance in order to improve the reliability of communication.



第三章 使用与操作 ChapterIII use and operation

3.1 键盘定义 Keys definition

键盘有 4 个按钮组成，分别是 There are four keys,they are  ,  ,  , 

 : 回到上一级画面，设置数据时：左移修改闪动位。

Go back to the next level,when setting the data: Move left to modify the flashing bit.

 : 画面向上切换，设置数据时：数据加一。

The screen switches up, when setting the data: the data plus one.

 : 画面向下切换，设置数据时：数据减一。

The screen switches down. When setting the data: the data minus one.

 : 进入下一级画面，设置数据时：1.长按 3S 进入设置界面。2.修改参数后确认返回。

Go to the next screen,When setting the data:1. Long press 3S to enter the setting interface. 2. Confirm the return after modifying parameters.

3.2 显示说明 Display

3.2.1 显示功能说明 Display definition

◇ 采用液晶显示，显示方式分为自动循环显示和按键显示两种，显示项目不可设，具体显示项见 3.2.2 说明。

LCD display,The display mode is divided into automatic cycle display and button display. The display items cannot be set.

For the specific display items, see 3.2.2.

◇ 显示具有背光功能，背光为白色，可通过按键点亮，无操作 2 个自动轮显周期后自动关闭。

The display has backlighting and the backlight is white,It can be turned on by pressing the key and shut off automatically after no operation of 2 automatic wheel display cycles.

◇ 可显示累计电能、电压、电流、功率、时间等信息。

it can display the accumulative energy, voltage, current, power, time and other information.







◇ 电能显示为 8 位数，显示 2 位或 3 位小数可设，计量单位 kWh。(注：出厂默认为 2 位小数，如有要求，请以实际产品为准；通讯支持读取 2 位和 3 位小数电能)

The energy is displayed as 8 digits, with 2 or 3 decimal places, and the unit of measurement is kWh.(Note:Factory default is 2 decimal places,if otherwise required, please refer to the actual product;Communication supports reading 2 and 3 decimal places of electrical energy)

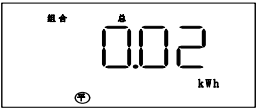
3.2.2 数据画面说明 Description of data screen

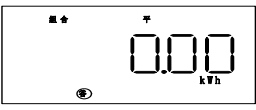
通过 ▲ 键或 ▼ 键可切换数据画面如下：

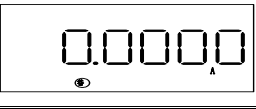
Through ▲ or ▼ toggles the data screen as follows:

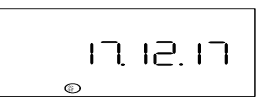
序号 NO	显示界面 Display interface	说明 Explain
1		组合总电量 combination total power
2		组合尖电量 combination sharp power
3		组合峰电量 combination peak power
4		组合平电量 combination flat power
5		组合谷电量 combination valley power
6		电压 voltage
7		电流 current
8		功率 power
9		日期 date

10		时间 time
11		表号高 4 位 The meter ID is 4 digits higher
12		表号低 8 位 The meter ID is 8 digits lower

3.2.3 参数设置画面 Parameter setting

长按 键 3S 进入密码界面，修改密码值为“3366”进入设置画面；

Long press Key 3s enters the password interface and modifies the password is 3366;

通过 键或 键切换所需设置菜单；

Through or to switch the required settings menu;

通过 键进入设置菜单修改界面，修改数值后按 键返回设置菜单，再按 键退出设置画面；

Through to the settings menu to modify the interface, after modifying the number, press back to the settings menu, and then press exit setting screen;

设置菜单说明如下图 The setup menu description is as follows:

		DL/T645-2007 地址高 6 位 DL / T645-2007 address is 6 bits high
		DL/T645-2007 地址低 6 位 DL / T645-2007 address is 6 bits low
DL/T645-2007 地址设置 DL/T645-2007 Address setting		
		Modbus-RTU 地址 Modbus-RTU Address
		Modbus-RTU 地址设置 Modbus-RTU Address setting

<div style="border: 1px solid black; padding: 10px; width: 100px; margin: 0 auto;">bAUD</div>	<div style="display: flex; justify-content: space-around; margin-bottom: 5px;"> <div style="border: 1px solid black; padding: 2px 10px;">09600n</div> <div style="border: 1px solid black; padding: 2px 10px;">09600o</div> <div style="border: 1px solid black; padding: 2px 10px;">09600E</div> </div>
	设置为 9600 None、9600 Odd 或 9600 Even Set to 9600 None, 9600 Odd or 9600 Even
	<div style="display: flex; justify-content: space-around; margin-bottom: 5px;"> <div style="border: 1px solid black; padding: 2px 10px;">19200n</div> <div style="border: 1px solid black; padding: 2px 10px;">19200o</div> <div style="border: 1px solid black; padding: 2px 10px;">19200E</div> </div>
	设置为 19200 None、19200 Odd 或 19200 Even Set to 19200 None, 19200 Odd or 19200 Even
	<div style="display: flex; justify-content: space-around; margin-bottom: 5px;"> <div style="border: 1px solid black; padding: 2px 10px;">01200n</div> <div style="border: 1px solid black; padding: 2px 10px;">01200o</div> <div style="border: 1px solid black; padding: 2px 10px;">01200E</div> </div>
	设置为 1200 None、1200 Odd 或 1200 Even Set to 1200 None, 1200 Odd or 1200 Even
	<div style="display: flex; justify-content: space-around; margin-bottom: 5px;"> <div style="border: 1px solid black; padding: 2px 10px;">02400n</div> <div style="border: 1px solid black; padding: 2px 10px;">02400o</div> <div style="border: 1px solid black; padding: 2px 10px;">02400E</div> </div>
	设置为 2400 None、2400 Odd 或 2400 Even Set to 2400 None, 2400 Odd or 2400 Even
<div style="display: flex; justify-content: space-around; margin-bottom: 5px;"> <div style="border: 1px solid black; padding: 2px 10px;">04800n</div> <div style="border: 1px solid black; padding: 2px 10px;">04800o</div> <div style="border: 1px solid black; padding: 2px 10px;">04800E</div> </div>	
设置为 4800 None、4800 Odd 或 4800 Even Set to 4800 None, 4800 Odd or 4800 Even	
通讯波特率及校验位设置 Communication baud rate and check bit setting	设置为 4800 None、4800 Odd 或 4800 Even Set to 4800 None, 4800 Odd or 4800 Even

<div style="border: 1px solid black; padding: 10px; width: 100px; margin: 0 auto;">nARCUr I</div>	<div style="border: 1px solid black; padding: 10px; width: 100px; margin: 0 auto;">010000</div>
最大电流设置 Maximum current setting	最大电流值 Maximum current value

第四章 技术指标 Chapter IV Technical indicators

4.1 规格 specifications (以下参数均以铭牌标注为准 The following parameters are subject to the nameplate)

额定电压(Un) Rated voltage (Un)	DC48V、DC100V、DC300V、DC500V、DC700V、DC750V、DC1000V
额定电流(In) Rated current (In)	50A、100A、200A、300A、500A 等可设置 (最大测量值 4800.0000A), 采用外置 75mV 分流器输入 50A, 100A, 200A, 300A, 500A and so on can be set (Maximum measured value 4800.0000A), using external 75mV shunt input.
脉冲常数 Pulse constant	以实际铭牌标注为准, 可设置。 It can be set according to the actual nameplate, may be set.
辅助电源 Power supply	供电电压, ①DC12V(±10%)、②DC9~60V、③DC20V~60V、④AC40~265V 或 DC40~330V 可选 Power supply ①DC12V(±10%), ②DC9~60V, ③DC20V~60V, ④AC40~265V or DC40~330V optional

4.1.1 脉冲常数与功率对照表 The table of pulse constant and power

序号 NO.	脉冲常数 Pulse constant (imp/kWh)	功率范围 Power range (W)
1	25600	900 > Pmax
2	12800	1800 > Pmax ≥ 900
3	6400	3600 > Pmax ≥ 1800
4	3200	7200 > Pmax ≥ 3600
5	1600	14400 > Pmax ≥ 7200
6	800	28800 > Pmax ≥ 14400
7	400	57600 > Pmax ≥ 28800
8	200	115200 > Pmax ≥ 57600
9	100	230400 > Pmax ≥ 115200
10	50	460800 > Pmax ≥ 230400
11	25	921600 > Pmax ≥ 460800
12	12	1920000 > Pmax ≥ 921600
13	6	3840000 > Pmax ≥ 1920000

4.2 技术参数 Technical parameter

4.2.1 基本误差 Basic error

在额定电压 (Un) 下, 电能表的基本误差不应超过下表的误差极限 Under rated voltage (Un), the basic error of the meter should not exceed the error limit of the meter below		
负载电流 (I) 变化范围 Load current (I) range of changes	误差限值 Error limit	
	0.5 级 0.5Class	1 级 1Class
0.01In ≤ I < 0.05In	±1.0%	—
0.02In ≤ I < 0.05In	—	±1.5%
0.05In ≤ I ≤ Imax	±0.5%	±1.0%

在额定电流 (In) 下, 电能表的基本误差不应超过下表误差极限 Under rated current (In), the basic error of the meter should not exceed the error limit of the meter below		
电压 (U) 变化范围 Voltage (U) variation range	误差限值 Error limit	
	0.5 级 0.5Class	1 级 1Class
$0.1U_n \leq U < 0.4U_n$	$\pm 1.0\%$	$\pm 1.5\%$
$0.4U_n \leq U < 1.3U_n$	$\pm 0.5\%$	$\pm 1.0\%$

4.2.2 潜动 Shunting

在参比条件下电能表电流线路短路, 电压电路分别施加 $1.1U_n$ 和 $0.8U_n$, 在 20min 时间内, 电能表不应有脉冲输出或代表脉冲输出的指示灯无闪烁。

In the reference condition, the current circuit of the power meter is short-circuited, and the voltage circuit is applied $1.1U_n$ and $0.8U_n$ respectively. In the 20min time, The meter should not have pulse output or indicator light representing pulse output without flashing.

4.2.3 功率消耗 Power consumption

电压线路 Voltage line	$\leq 1W$
电流线路 Current line	$\leq 0.5W$
辅助电源线路 Power supply line	$\leq 2W$

4.2.4 工作环境条件 Working conditions

工作温度范围 Working temperature	$-25^{\circ}C \sim 60^{\circ}C$
极限工作温度范围 The limit working temperature	$-40^{\circ}C \sim 70^{\circ}C$
储存运输极限温度 Storage transport limit temperature	$-40^{\circ}C \sim 70^{\circ}C$
相对湿度 Relative humidity	$< 75\%$ (年平均) $< 75\%$ (The annual average)

4.2.5 通讯参数 Communication parameters

4.2.5.1 通讯接口 Communication port

仪表配置有一个 RS485 通讯接口和红外通讯接口。

The meter configuration has a RS485 communication port and an infrared communication port.

4.2.5.2 数据读写 Data reading and writing

通过 RS485 接口, 可完成参数设置和抄读数据。兼容 DL/T 645-2007、Modbus-RTU 协议, 通讯时自动识别切换, 各协议实现功能分别如下:

Parameter setting and reading data can be completed through the RS485 interface. Compatible with DL/T 645-2007, Modbus-RTU protocol, automatic identification switching during communication, the functions of each protocol are as follows:

DL/T645-2007 协议: 可读取实时电参量 (电压、电流、功率等), 当前有功电能及费率电能, 上月 12 月结算电能, 事件记录数据。费率设置, 电表清零功能。具体参照对应协议详述。

DL/T645-2007 protocol: It can read real-time electrical parameters (voltage, current, power,), current active power and rate

power, settle energy in last December, event recording data. Rate setting, meter clear function. Refer to the corresponding protocol for details.

Modbus-RTU协议：可读取实时电参量（电压、电流、功率），当前有功电能及费率电能。可设置第一套费率，电表清零功能。具体参照对应协议详述。

Modbus-RTU protocol: It can read real-time electrical parameters (voltage, current, power,), current active power and rate power, It can set the first rate, meter clear function. Refer to the corresponding protocol for details.

4.2.5.3 通讯参数设置 Communication parameter setting

通讯地址、波特率、校验位可通过按键设置和RS485接口设置。

Communication address, baud rate, check bit can be set by key and communication.

通讯地址：DL/T645-2007协议通讯地址默认为产品编码（12位BCD码），Modbus协议地址默认为01。

Communication address: The DL/T645-2007 protocol communication address defaults to the product code (12-bit BCD code), the Modbus protocol address defaults to 01.

波特率：1200/2400/4800/9600/19200bps可设， 校验位（可设）：奇/偶/无。

Baud rate: 1200/2400/4800/9600/19200bps Can be set, Check bit (can be set): odd / even / none.

注：默认出厂为2400bps，偶校验。校验位如另有要求，请以实际产品为准。

Note: The default factory is 2400bps, even parity. If the check digit is required, please refer to the actual product.

4.2.6 电磁兼容 Electromagnetic compatibility

绝缘强度 Dielectric strength	电压/电源/外壳：3.0kV/min Voltage / Power / Sheet: 3.0kV/min 通讯/电源：3.0kV/min Communication / power supply: 3.0kV/min
静电抗扰 Static immunity	接触放电 8 kV Contact Discharge 8 kV 空气放电 15 kV Air Discharge 15 kV
电快速脉冲群抗扰性 Electrical fast burst immunity	4kV
浪涌抗扰性 Surge immunity	2kV/4kV

第五章 维护和故障排除 Chapter V maintenance and troubleshooting

5.1 故障排除 Troubleshooting

可能问题 Possible issues	可能原因 Possible causes	可能解决方案 Possible solutions
上电后无显示 No display after power-on	电源未能加入到设备上 The power supply is not added to the meter	检查设备 L/+和 N/- 端子上是否加入了正确的工作电压 Check the meter L/+ and N/- whether the correct working voltage is added on the terminal
加信号后测量数据不准确或显示为 0 After adding the signal, the measurement data is not accurate or displayed as 0	电压测量不正确 Voltage measurement is wrong	检查电压信号是否正确接入设备 Check whether the correct voltage signal is added on the meter 检查电压测量信号是否在设备测量范围内 Check whether the voltage measuring signal is within the measuring range of the meter
	电流测量不准确 Current measurement is wrong	检查电流信号是否正确接入设备 Check whether the correct current signal is added on the meter 检查电流测量信号是否在设备测量范围内 Check whether the current measuring signal is within the measuring range of the meter
开关量状态不变化 Switching state does not change	开关量输入错误 Digital input error	检查设备是否配有开关量输入功能 Check whether the meter is equipped with digital input function 检查外部接线是否正确 Check if the external wiring is correct
继电器不动作 Relay non-action	没有接收到控制命令 Control command not received	检查相关设置是否正确（在哪种模式下） Check if the Settings are correct (in which mode) 若是通讯控制，检查通讯是否成功 If communication controls are available, check that the communication is successful
	无继电器功能 No relay function	检查设备是否配有继电器功能 Check whether the meter is equipped with relay function
上位机不能与设备通讯 The upper computer cannot communicate with the meter	无通讯功能 No communication function	检查设备是否配有通讯功能 Check if the device is equipped with communication function
	通讯参数不正确 Communication parameters are incorrect	检查通讯地址是否正确 Check if the mailing address is correct 检查通讯波特率是否正确 Check if the communication baud rate is correct 检查通讯校验位是否正确 Check if the communication check digit is correct
	通讯链路受影响 Communication links are affected	检查同一个通讯链路上是否有相同参数的设备 Check if there is a device with the same parameters on the same communication link 检查通讯屏蔽层是否良好接地 Check that the communication shield is well grounded 检查通讯电缆是否断开 Check if the communication cable is disconnected

注：如果有一些无法解决的问题，请及时与我们公司的售后服务部门联系。

Note: If there are some problems that cannot be solved, please contact our after-sales service department in Time.

第六章 质量保证 Chapter VI Quality Assurance

6.1 质量保证 Quality Assurance

所有售给用户的新仪表，在通电运行后 12 个月或收到货后 18 个月内，对其因设计、材料和工艺引起的故障实行免费质量保证，如经认定产品符合上述质保条件，我公司负责免费维修。

All new meters sold to customers shall be provided with free quality assurance for the faults caused by design, materials and process within 12 months after power-on or 18 months after receiving the goods. If the products are determined to meet the above quality guarantee conditions, our company shall be responsible for free maintenance.

6.2 质量限制 The quality of limit

以下装置的问题不属免费质保范围：

Problems with the following devices are not covered by free warranty:

- 由于不正确的安装、使用、存储引起的损坏。

Damage due to incorrect installation, use, and storage.

- 超出产品规定的非正常操作和应用条件。

Excessive operating and application conditions beyond the product specifications.

- 由非本公司授权的机构或人修理了的仪表。

The meter that has been repaired by an organization or person that is not authorized by the company.

- 超出免费质保年限了的仪表。

The meter that exceeds the free warranty period.

注：以上图片仅供参考，以实际出货为准。

Note: The above pictures are for reference only, the products are subject to the actual product.



地址：广东省河源市高埔岗雅达工业园

Address: Yada industry park, Gaopugang, Heyuan city,
Guangdong Province.

国内业务 Domestic market: 86-762-3493871 3493872 3493873

国外业务 International market: 86-762-3496222

技术支持 Technical support: 86-762-3493926 3493989 (400-830-0868)

传 真 Fax: 86-762-3493912 3493830

邮 编 Zip code: 517000

http: //www.yada.com.cn

E-mail: market@yada.com.cn

版权所有，保留一切权利。内容如有改动，恕不另行通知。

Copyright, all rights reserved. Specification subject to change without prior notice.