



NO: 13040502.0265.00

DTSD3366D-J 系列三相电子式多功能电能表
DTSD3366D-J Series Three - phase electronic multi -
function energy meter

说明书

Instructions

广东雅达电子股份有限公司
Guangdong Yada Electronics Co., Ltd



危险和警告 Danger and warning

在进行安装、操作或者维护此设备之前，请仔细阅读本手册，拿到它并逐步熟悉设备。本文件不是一本适用于未受训者的操作手册，在其正常使用范围之外所引起的问题，本公司概不负责。

Before installing, operating or maintaining the equipment, please read this manual carefully, get it and gradually get familiar with the equipment. This document is not an operating manual for non-trainees, and our company are not responsible for any problems arising out of its normal use.



触电、燃烧或者爆炸的危险 Risk of electric shock, fire or explosion

- 本设备部分存在电力危险，请严格按照规范进行作业。

There is a power hazard in some parts of this equipment. Please operate in strict accordance with the specifications.

- 在维护和检修之前，设备必须断电并接地。

Before maintenance and overhaul, the equipment must be powered off and grounded.

- 在设备通电前，应将所有的机械部件，门和盖子等恢复原位。

All mechanical parts, doors and covers should be returned to their original position before the equipment is energized.

- 设备维护和安装工作只能由有资质的人员执行。

Equipment maintenance and installation work can only be performed by qualified personnel.

若不注意这些预防措施可能会引起严重伤害。

If you do not pay attention to these precautions, it may cause serious injury.

目录 Contents

| | |
|--|-----------|
| 第一章 产品介绍 Chapter I Introduction | 1 |
| 1.1 概述 Overview | 1 |
| 1.2 相关技术标准 The technical standards..... | 1 |
| 1.3 型号说明 Model Description | 1 |
| 1.4 功能介绍 Main function | 2 |
| 1.4.1 电能计量 Energy metering | 2 |
| 1.4.2 需量测量 Demand measurement | 2 |
| 1.4.3 时钟 Clock | 3 |
| 1.4.4 费率和时段 Rates and periods..... | 3 |
| 1.4.5 事件记录 Event record..... | 4 |
| 1.4.6 显示功能 Display function | 4 |
| 1.4.7 瞬时测量 Instantaneous measurement | 4 |
| 1.4.8 通信功能 Communications functions | 4 |
| 1.4.9 按键操作 keys operation | 5 |
| 1.4.10 输出接口 Output interface..... | 5 |
| 第二章 安装 Chapter II Installation | 6 |
| 2.1 安装预防、准备 Installation prevention, preparation..... | 6 |
| 2.2 安装信息 Installation Information | 6 |
| 2.2.1 安装环境和位置 Installation environment and location | 6 |
| 2.2.2 安装尺寸 Installation size..... | 7 |
| 2.3 端子定义 Terminal definition | 8 |
| 2.4 接线示意图 Wiring drawing | 9 |
| 2.4.1 三相四线直接接入接线图 Three-phase four - wire direct access to the wiring diagram..... | 9 |
| 2.4.2 三相四线经 CT 接入接线图 Three-phase four - wire access by CT wiring diagram..... | 9 |
| 2.4.3 通讯 Communication | 10 |
| 第三章 使用与操作 Chapter III use and operation | 11 |
| 3.1 键盘定义 Keys definition..... | 11 |
| 3.2 显示说明 Display..... | 11 |
| 3.2.1 显示功能说明 Display definition | 11 |
| 3.2.2 数据画面说明 Data picture description | 12 |
| 3.2.3 参数设置画面 Parameter setting screen | 13 |
| 3.2.4 设置查询举例 Example of setting query | 15 |

| | |
|--|-----------|
| 第四章 技术指标 Chapter IV Technical indicators | 16 |
| 4.1 准确度 Accuracy..... | 16 |
| 4.2 规格参数 Specification parameters..... | 16 |
| 4.3 适用范围 Range of application..... | 16 |
| 4.4 环境条件 Working conditions..... | 16 |
| 4.5 功耗 Consumption..... | 17 |
| 4.6 通讯 Communication..... | 17 |
| 4.7 电气特性 Electrical characteristics..... | 17 |
| 4.8 电磁兼容 Electromagnetic compatibility..... | 17 |
| 4.9 计时准确度 Timing accuracy..... | 18 |
| 第五章 维护和故障排除 Chapter V Maintenance and troubleshooting | 19 |
| 5.1 故障排除 Troubleshooting..... | 19 |
| 第六章 质量保证 Chapter VI Quality Assurance | 20 |
| 6.1 质量保证 Quality Assurance..... | 20 |
| 6.2 质量限制 The quality of limit..... | 20 |

第一章 产品介绍 Chapter I Introduction

1.1 概述 Overview

三相电子式多功能电能表系列产品博采国际上众家之长，是本公司符合国家电网公司三相智能电能表技术规范的新一代适用于充电桩上的电能计量装置。我们对该型号表进行了大量的可靠性冗余设计。各项技术指标符合《GB/T17215.321-2008》、《GB/T 17215.322-2008》、《DL/T645-2007》、《GB/T28569-2012》等国家标准以及行业标准。具有测量精度高、性能稳定可靠、长寿命、体积小、重量轻、功耗低、操作简便、易于实现管理功能的扩展、一表多用等特点。可广泛应用于电动汽车交流充电桩电能计量。

The three-phase electronic multi-function energy meter series is a new-generation electric energy metering device suitable for charging piles, which is in line with the technical specifications of the three-phase intelligent energy meter of state grid corporation of China. We have done a lot of reliability redundancy design for this model table. The technical indicators are in line with national standards such as 《GB/T17215.321-2008》、《GB/T 17215.322-2008》、《DL/T645-2007》、《GB/T28569-2012》 and other industrial standards. It has the characteristics of high measurement accuracy, stable and reliable performance, long life, small size, light weight, low power consumption, simple operation, easy to realize the expansion of management function, multi-purpose of one table and so on. It can be widely used in electric vehicle ac charging pile energy metering.

1.2 相关技术标准 The technical standards

GB/T17215.321-2008 《交流电测量设备 特殊要求 第 21 部分：静止式有功电能表（1 级和 2 级）》

GB/T17215.321-2008 "particular requirements for alternating current measuring equipment - part 21: static active watt-hour meters (class 1 and 2)"

GB/T17215.322-2008 《交流电测量设备 特殊要求 第 22 部分：静止式有功电能表（0.2S 级和 0.5S 级）》

GB/T17215.322-2008 "particular requirements for alternating current measuring equipment - part 22: static active watt-hour meters (class 0.2s and 0.5s)"

GB/T28569-2012 《电动汽车交流充电桩电能计量》

GB/T28569-2012 "electric energy measurement of ac charging piles for electric vehicles"

DL/T645-2007 《多功能电能表通信协议》

DL/T645-2007 "multifunction electricity meter communication protocol"

1.3 型号说明 Model Description

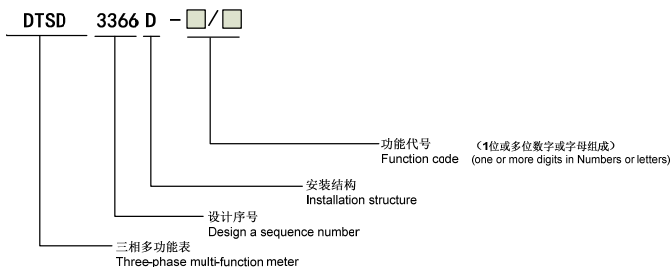

详细选型简介 Detailed selection introduction:

| 型号 Model | 功能 Function |
|-------------|--|
| DTSD3366D-J | 三相多功能、复费率、一路有功电能脉冲输出、一路秒脉冲输出（或无功电能脉冲输出） Three-phase multi-function, multi-rate, one active power pulse output, one second pulse output (or reactive power pulse output) |

1.4 功能介绍 Main function

1.4.1 电能计量 Energy metering

- ◇ 组合有功、正向有功、反向有功电能计量功能。出厂默认组合有功=正+反。
Combined active power, forward active power and reverse active power metering function. Factory default combination active power = positive + negative.
- ◇ 四象限无功电能，出厂默认无功 1= I + II，无功 2=III+IV。也可通过软件编程四象限任意组合。
Four quadrant reactive power, the factory default reactive 1= I + II, 2=III+IV reactive. Software programming can also be arbitrary combination of the four quadrants.
- ◇ 分时计量功能，即可按相应的时段分别累计、存储总、尖、峰、平、谷有功电能。
The time-sharing metering function accumulates and stores the total, peak, peak, flat and valley active energy respectively according to the corresponding time period.
- ◇ 能存储 12 个结算日电量数据，存储的各结算周期电能量,各费率电能量数据应为电量累计值。
It can store electric quantity data of 12 settlement days, electric energy of each settlement cycle stored, and electric energy data of each rate shall be the accumulative value of electric quantity.
- ◇ 电能量参数不可设置底度值，只能清零（能通过按键密码电能清零）。
Electrical energy parameters cannot be set to the bottom value, only zero(Can reset power by key password).
- ◇ 组合有功、组合无功电能的符号位由最高字节的第一个二进制位表示，0 正，1 负，因此组合有功、组合无功的 数值范围变为：0.00~799999.99。对此，要求在到达极限值时进行归零处理。
The symbol bit of combined active power and combined reactive power is represented by the first binary bit of the highest byte, 0 positive and 1 negative, so the value range of combined active power and combined reactive power becomes: 0.00~799999.99. In this case, it is required to return to zero when the limit value is reached.
- ◇ 在重新设置有功(无功)组合状态字后，组合有功(无功)电能原来组合有功(无功)电能的基础上进行累计。
After the active (reactive) combination state word is reset, the combined active (reactive) energy accumulates on the basis of the original combined active (reactive) energy.

1.4.2 需量测量 Demand measurement

- ◇ 正向有功、反向有功最大需量及其出现的日期和时间。
Maximum demand for forward and reverse active power and the date and time of its occurrence.
- ◇ 组合有功最大需量及其出现的日期和时间。
The combined maximum demand for active power and the date and time of its occurrence.

- ◇ 可按相应的时段分别累计、存储总、尖、峰、平、谷有功最大需量及其出现的日期和时间。（可选项）

Maximum demand can be reset manually and by command. In the programming state, press "up" and "down" at the same time for 3 seconds to reset manual demand. (Optional)

- ◇ 最大需量可手动和命令清零。在编程状态下，同时按“上翻”和“下翻”键持续 3 秒钟可进行手动需量清零。

Maximum demand can be reset manually and by command. In the programming state, press "up" and "down" at the same time for 3 seconds to reset manual demand.

- ◇ 需量周期可在 5、10、15、30、60min 中选择；滑差式需量周期的滑差时间可以在 1~5min 中选择；需量周期应为滑差时间的 5 的整数倍。最大需量测量采用滑差方式，需量周期和滑差时间可设置。出厂默认：需量周期 15min、滑差时间 1min。

Demand cycle can be selected from 5, 10, 15, 30, 60min; Slip time of slip demand cycle can be selected from 1~5min. The demand period should be an integer multiple of 5 of the slip time. Slip mode is adopted for maximum demand measurement, and slip period and slip time can be set. Factory default: demand cycle 15min, slip time 1min.

- ◇ 当上电、清零、时钟调整、时段转换、需量周期变更、功率潮流方向转换等情况时，电能表从当前时刻开始按照需量周期进行需量测量；当第一个周期完成后，按滑差间隔开始最大需量记录；在不完整的周期内，不做最大需量的记录。

When power on, reset, clock adjustment, time period conversion, demand cycle change, power flow direction conversion, etc. When the first cycle is completed, record the maximum demand according to slip interval. No record of maximum demand is made for incomplete periods.

- ◇ 时段转换时，总需量连续计量，各费率需量重新开始计算。

When the time period is changed, the total demand is measured continuously, and the demand of each rate is calculated again.

1.4.3 时钟 Clock

- ◇ 广播校时不受密码和硬件编程开关限制；广播校时每天只允许一次，电能表可接受的广播校时范围不得大于 5min，且在午夜零点前后 10 分钟内不能进行广播校时，当校正时间大于 5min 时，电能表只有通过现场进行校时。

Broadcast pair time is not limited by password and hardware programming switch; Broadcast calibration is allowed only once a day. The broadcast calibration range acceptable by the energy meter shall not be more than 5min, and cannot be performed within 10 minutes before or after midnight. When the calibration time is more than 5min, the energy meter can only be performed on site.

1.4.4 费率和时段 Rates and periods

- ◇ 支持尖、峰、平、谷四个费率。

Support sharp, peak, flat, valley four rates.

- ◇ 年时区数最大为 14，每套时段表内最多有 8 个日时段表，日时段数最大为 14；时段最小间隔为 15 分钟，且应大于电能表内设定的需量周期；时段可以跨越零点设置。设置时区表或日时段表时，电表记录设置时刻和设置前的时区或日时段。

The maximum number of time zones in a year is 14, and there are a maximum of 8 daily time zones in each set of time zones, and the maximum number of daily time zones is 14; The minimum time interval is 15 minutes, and should be greater than the demand cycle set in the watt-hour meter; Time slots can be set across zeros. When setting time zone meter or daily time period meter, the electricity meter records the setting time and the time zone or day period before setting.

- ◇ 支持 254 个节假日特殊费率时段的设置。设置假日时，电表记录设置时刻和设置前的公共假日。

Support the setting of 254 holiday special rate periods. When setting holidays, the meter records the setting time and the public holidays before setting.

- ◇ 两套时区表可以任意编程，并可设定两套时区表切换时间，定时在两套时区表之间切换，通过电表运行状态 3 中的第 5 位了解表计当前使用的是第 1 套还是第 2 套时区表。

The two sets of time zone tables can be programmed arbitrarily, and the switching time of the two sets of time zone tables can be set regularly to switch between the two sets of time zone tables. It can be known whether the first set or the second set of time zone tables are currently used by the 5th bit in the running state 3 of the electricity meter.

1.4.5 事件记录 Event record

包括编程记录、校时记录、失压记录、失流记录、断相记录、电能表清零记录。

It includes programming record, calibration record, loss of voltage record, loss of current record, phase record, electricity meter zero record.

1.4.6 显示功能 Display function

- ◇ 显示分为自动循显和按键循显两种方式，显示项目可通过上位机按要求进行设置。

Display can be divided into two modes: automatic tracking display and key tracking display.

- ◇ 循环显示周期可通过上位机在 5s~20s 范围内设置，默认值为 5s。

The display cycle can be set in the range of 5s~20s by the upper computer. The default value is 5s.

- ◇ 显示带背光，可通过按键或红外等触发方式点亮 LCD 背光，当点亮背光后，无按键操作时，30 秒后关闭 LCD 背光。

Display with backlight, the LCD backlight can be lit through the button or infrared trigger mode, when the backlight is lit, no button operation, after 30 seconds to close the LCD backlight.

1.4.7 瞬时测量 Instantaneous measurement

- ◇ 电能表自动测量并显示实时电网的瞬时量。

The energy meter automatically measures and displays the instantaneous quantity of the real-time power grid.

- ◇ 测量各回路和总有功、无功及视在功率、瞬时功率因数；各相电压、电流有效值、相角；电网瞬时频率值。

Measure the total active power, reactive power, apparent power and instantaneous power factor of each circuit; Effective value and phase Angle of voltage and current of each phase; Instantaneous frequency value of power network.

1.4.8 通信功能 Communications functions

- ◇ 本仪表配置有一个 RS485 通讯接口，RS485 通讯波特率为 1200bps、2400bps、4800bps、9600bps、19200bps 可设，出厂默认 2400bps，偶校验。通过 RS485 接口，可与 PC 机完成编程参数设置和抄读数据。

This meter is equipped with a RS485 communication interface, RS485 communication baud rate of 1200bps, 2400bps, 4800bps, 9600bps, 19200bps can be set, factory default 2400bps, even check. Through the RS485 interface, it can set programming parameters and read data with PC.

- ◇ 红外通讯功能，电表也可以通过红外与掌上电脑通讯进行数据的抄读和相关设置，红外通讯波特率固定为 1200bps。

Infrared communication function, the electricity meter can also read and set the data through the infrared communication with the handheld computer. The infrared communication baud rate is fixed at 1200bps.

1.4.9 按键操作 keys operation

- ◇ 可通过按键设置设备地址、PT 变比、CT 变比、波特率、校验位、系统时间、电能清零。

Device address, PT ratio, CT ratio, baud rate, check bit and system time can be set by pressing the key, Energy clearing.

1.4.10 输出接口 Output interface

- ◇ 电能脉冲输出，具有有功、无功电能脉冲输出，脉冲宽度为 $80\text{ms} \pm 20\text{ms}$ ，电脉冲经光电隔离后输出。

Power pulse output, with active and reactive power pulse output, pulse width is $80\text{ms} \pm 20\text{ms}$, the electric pulse output after photoelectric isolation.

- ◇ 有功电能脉冲指示灯：红色；平时灭，计量有功电能时闪烁。

Active power pulse indicator light: red; Normally off, measure active energy flicker.

- ◇ 无功电能脉冲指示灯：红色；平时灭，计量无功电能时闪烁。

Reactive power pulse indicator light: red; Normally off, when the measurement of reactive power flicker.

- ◇ 秒脉冲输出，其中秒脉冲输出与无功电能脉冲输出复用，可通过编程设置进行切换，电能表断电后再次上电，默认为秒脉冲输出。

Second pulse output, in which second pulse output and reactive power pulse output multiplexing, can be set through programming switching, electricity meter power again after the power off, the default for the second pulse output.

第二章 安装 Chapter II Installation

2.1 安装预防、准备 Installation prevention, preparation

请在开始操作前阅读 Please read before starting the installation

本章包含重要的安全预防信息，在安装、服务或维护电气设备前必须遵守这些指导。仔细阅读并遵循下列安全预防指导。

This chapter contains important safety precautions that you must follow before installing, servicing, or servicing electrical equipment.

Read and follow the following safety precautions carefully.



电击，烧毁或爆炸的危险，所以只有合格的操作人员才能安装本设备。此工作应在阅读了该全部指导后开展。在进行安装，检验，测试或维护前，应断开所有的电源连接。请依照说明书中的接线说明接线，接完后要认真核对接线是否正确无误。意识到潜在的危险，工作人员需佩戴保护设备，仔细检查工作接线和安装是否正确。安装或者拆除仪表时，请确认电源、待测信号源及相关电源是否完成断开。



The danger of electric shock, fire or explosion, so that only qualified personnel can install the equipment. This work should be carried out after reading all of this guidance. In the visual inspection, testing or maintenance, should disconnect all power connection. Please follow the wiring instructions in the instructions and carefully check if the wiring is correct. Aware of the potential danger, workers need to wear protective equipment and carefully check the wiring and installation is correct. When installing or removing the meter, make sure the power supply, signal source to be measured and related power supply are completely disconnected.

2.2 安装信息 Installation Information

2.2.1 安装环境和位置 Installation environment and location

装置应安装在干燥、清洁、远离热源和强电磁场的地方，避免阳光直射。安装位置应在不受油、污物、灰尘、腐蚀性气体或其他有害物质的侵袭。安装时要注意检修方便，有足够的空间放置有关的线、端子排、短接板和其他必要的设备。

The device should be installed in dry, clean, away from heat source and strong electromagnetic field, avoid direct sunlight. The installation should be free from oil, dirt, dust, corrosive gas or other harmful substances. Pay attention to convenient maintenance during installation, there is enough space to place the relevant line, terminal bar, short board and other necessary equipment.

2.3 端子定义 Terminal definition



电流方向：下侧进线上侧出线
端子图

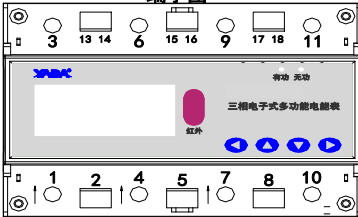

电流方向：上侧进线下侧出线
端子图

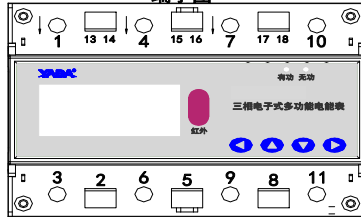

| | | | |
|----------------------|---|----------------------|---|
| 电流方向：下侧进线上侧 出线端子图 | Current direction: lower side incoming line and upper side outgoing line Terminal diagram | 电流方向：上侧进线下侧出 线端子图 | Current direction: upper side incoming line and lower side outgoing line Terminal diagram |
| 有功/无功 | Active/Reactive | 三相电子式多功能电能表 | Three - phase electronic multi - function energy meter |
| 红外 | Infrared | | |

| 端子号 Terminal NO | 注释 Remark | 端子号 Terminal NO | 注释 Remark |
|--------------------|--|--------------------|--|
| 1 | A 相电流输入 A Phase current input | 3 | A 相电流输出 A Phase current output |
| 4 | B 相电流输入 B Phase current input | 6 | B 相电流输出 B Phase current output |
| 7 | C 相电流输入 C Phase current input | 9 | C 相电流输出 C Phase current output |
| 10 | N 零线输入 N zero line input | 11 | N 零线输出 N zero line output |
| 2 | A 相电压输入 A Phase voltage input | 5 | B 相电压输入 B Phase voltage input |
| 8 | C 相电压输入 C Phase voltage input | | / |
| 13 | RS485 端口 A RS485 port A | 14 | RS485 端口 B RS485 port B |
| 15 | 有功电能脉冲+ Active energy pulse + | 16 | 有功电能脉冲- Reactive energy pulse - |
| 17 | 秒脉冲+ (或无功电能+) Second pulse + (or reactive energy +) | 18 | 秒脉冲- (或无功电能-) Second pulse - (or reactive energy -) |

注:

- 1、当直接接入时（不外接 CT 时）即额定输入为 $3 \times 5(40)A$ 、 $3 \times 5(60)A$ 、 $3 \times 10(60)A$ 和 $3 \times 10(40)A$ 、 $3 \times 10(80)A$ 、 $3 \times 20(80)A$ 时，端子号 2、5、8 为预留端子，不可接入电压；
- 2、端子号 10、11 是连通的，可以只接 10 号或 11 号端子；
- 3、端子号 17、18 为秒脉冲和无功电能脉冲复用，出厂默认为秒脉冲输出，可通过上位机更改为无功电能脉冲输出；
- 4、当外接 CT 时即额定输入为 $3 \times 1.5(6)A$ 时，端子号 2、5、8 为电压输入，每个端子都为 2P，可以任意接 1P。

Note:

1. When directly connected (without external CT), i.e. rated input is $3 \times 5(40)A$, $3 \times 5(60)A$, $3 \times 10(60)A$, $3 \times 10(40)A$, $3 \times 10(80)A$, $3 \times 20(80)A$, terminal no. 2, 5 and 8 are reserved terminals, and the voltage cannot be connected.
2. Terminal 10, 11 is connected, can only connect 10 or 11 terminal.
3. Terminal Numbers 17 and 18 are second pulse and reactive power pulse multiplexing. The factory default is second pulse output, which can be changed to reactive power pulse output by the upper computer.
4. When external CT is connected, namely rated input is $3 \times 1.5(6)A$, terminal no. 2, 5 and 8 are voltage input, each terminal is 2P, and 1P can be connected arbitrarily.

2.4 接线示意图 Wiring drawing

2.4.1 三相四线直接接入接线图 Three-phase four - wire direct access to the wiring diagram

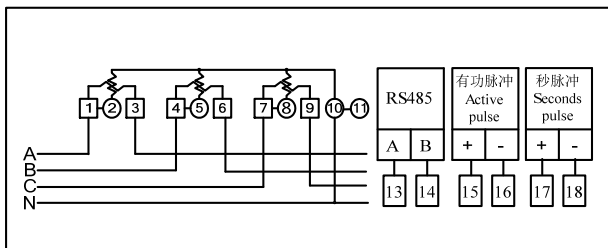

2.4.2 三相四线经 CT 接入接线图 Three-phase four - wire access by CT wiring diagram

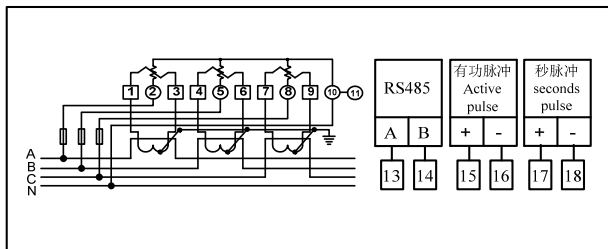

2.4.3 通讯 Communication

RS-485通信口，端子标记为13、14。 RS-485 communication port, terminal marked 13, 14.



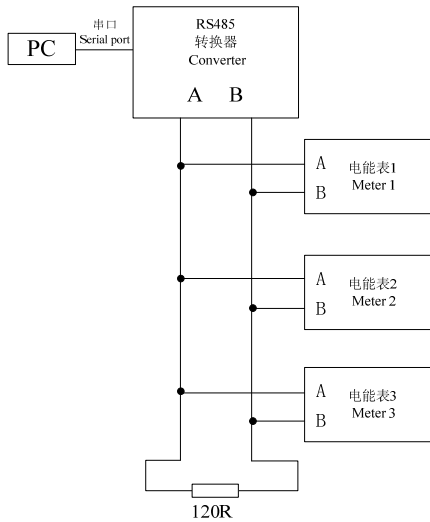

RS-485 通信方式允许一条总线上最多接 32 台电能表，通过一个 RS-485 转换器与上位机连接。通信电缆可以采用普通的屏蔽双绞线，总长度不宜超过 1200 米，各个设备的 RS-485 口正负极性必须连接正确。如果屏蔽双绞线较长，建议在其末端接一个约 120Ω 的电阻以提高通信的可靠性。





The RS-485 communication mode allows up to 32 meters to be connected to a single bus and to the upper computer through an RS-485 converter. Communication cable can use ordinary shielded twisted pair, the total length should not exceed 1200 meters, each equipment RS-485 port positive and negative polarity must be connected correctly. If shielded twisted-pair cable is longer, Suggestions on its end by one of about 120 Ω resistance in order to improve the reliability of communication.



第三章 使用与操作 Chapter III use and operation

3.1 键盘定义 Keys definition

键盘有 4 个按键组成，分别是 There are four keys, they are  ,  ,  , 

| | |
|---|---|
|  | 移位键：设置时闪烁位左移键 Shift key: flicker left shift key when setting |
|  | 上翻键：显示或设置时向上翻动菜单或键入数值时作为递增的功能 Up key: the function to turn up the menu or to enter a value as an increment when displaying or setting |
|  | 下翻键：显示或设置时向下翻动菜单或键入数值时作为递减的功能 Down key: function to turn down the menu or function to decrement as you type a value e when displaying or setting |
|  | 设置键：进入设置功能，在系统参数设定菜单中为确定功能 Setting key: enter the setting function. In the system parameter setting menu, it is the setting function |

3.2 显示说明 Display

3.2.1 显示功能说明 Display definition

- ◇ 采用液晶显示，显示方式分为自动循环显示和按键切换显示两种。

LCD display, The display mode is divided into automatic cycle display and button display.

- ◇ 默认显示 Modbus-RTU 通协地址、DL/T645 通讯地址、系统时间、组合有功尖电能、组合有功峰电能、组合有功平电能、组合有功谷电能、组合有功总电能、A 相电压、B 相电压、C 相电压、A 相电流、B 相电流、C 相电流、频率、功率因素、A 相有功功率、B 相有功功率、C 相有功功率、总功率、A 相无功功率、B 相无功功率、C 相无功功率、总无功功率等。

The default display Modbus-RTU communication association address, DL/T645 address, the system time, combined active sharp peak electricity, electricity, combined active combination active flat valley electricity, combined active power, combined active power, A phase voltage and phase voltage B, C phase voltage, phase current phase current, B, C phase current, frequency, power factor, active power, B phase active power, active power and total power C phase, A phase of reactive power and B phase reactive power, phase C reactive power, total reactive power, etc.

- ◇ 电能量显示为 8 位数，2 位小数，计量单位 MWh 或 kWh，组合有功电能的符号位由最高字节的第一个二进制位表示，0 正，1 负，因此组合有功的数值范围变为：0.00~799999.99，对此，要求在到达极限值时进行归零处理。

The electric energy is shown as 8 digits, 2 decimal places, measuring unit MWh or kWh. The symbol bit of the combined active energy is represented by the first binary bit of the highest byte, 0 +, 1 -, so the value range of the combined active energy is changed into: 0.00~799999.99. For this reason, it is required to reset to zero when the limit value is reached.

- ◇ 无功功率可测、可显示范围 0~999.9999kvar，超出 999.9999kvar，将溢出，无法正确显示。

Reactive power can be measured and display range 0~999.9999kvar. If it exceeds 999.9999kvar, it will overflow and cannot be displayed correctly.

3.2.2 数据画面说明 Data picture description

通过 ▲ 键或 ▼ 键可切换数据画面如下（节选部分） Through ▲ or ▼ toggles the data screen as

follows(excerpts):

| 序号 NO. | 显示界面 Display interface | 说明 Explain |
|--------|------------------------|--|
| 1 | | Modbus 地址 Modbu address |
| 2 | | DL/T645 的地址低 8 位 Addresses low 8 bits of DL/T645 |
| 3 | | DL/T645 的地址高 4 位 Addresses high 4 bits of DL/T645 |
| 4 | | 组合有功尖电能 Combined active sharp energy |
| 5 | | 组合有功峰电能 Combined active peak energy |
| 6 | | 组合有功平电能 Combined active flat energy |
| 7 | | 组合有功谷电能 Combined active valley energy |
| 8 | | 组合有功总电能 Combined active total energy |
| 9 | | A 相电压 A phase voltage |
| 10 | | A 相电流 A phase current |

| | | |
|----|--|-----------------------------------|
| 11 | | A 相有功功率 A phase active power |
| 12 | | 总有功功率 Total active power |
| 13 | | A 相无功功率 A phase reactive power |
| 14 | | 总无功功率 Total reactive power |
| 15 | | 总功率因素 Total power factor |
| 16 | | 频率 Frequency |

3.2.3 参数设置画面 Parameter setting screen

系统参数设置中液晶显示字符含义 LCD character meaning in system parameter setting

| 序号 NO. | LCD 图形 LCD Figure | 说明 Explain |
|--------|-------------------|---|
| 1 | PSd 3366 | 仪表密码，默认密码为 3366 Meter password, default password is 3366 |
| 2 | -Ad SET- | “AD SET” ModBus 地址 “AD SET” ModBus address |
| 3 | -Pt SET- | “PT SET”电压变比 “PT SET”Voltage ratio |
| 4 | -Ct SET- | “CT SET”电流变比 “CT SET”Current ratio |
| 5 | -rAdSEt- | “MAD SET”Modbus 地址 “MAD SET”Modbus 地址 address |
| 6 | -bd SET- | 波特率 Baud rate |
| 7 | -rEtCSEt- | 系统时钟 System clock |
| 8 | -rEtUrN- | “RETURN”退出，退回测量界面 “RETURN”Exit, return to the measurement interface |
| 9 | -CLrEnE- | 电能清零 Energy clearing |
| 10 | -Cur rEu | “CUR REV”电流进线方向设置 “CUR REV” Direction setting of current incoming line |



















| 序号 NO. | LCD 图形 LCD Figure | 说明 Explain |
|--------|-------------------|--|
| 11 | --bACK- | “BACK”返回上一级 “BACK” Back to the previous level |
| 12 | 0000 I | 变比数字 Ratio digital |
| 13 | L 00000 I | 645 地址低位数字 645 Address lower digit |
| 14 | H 000000 | 645 地址高位数字 645 Address higher digit |
| 15 | ---0 I--- | 回路数字 Loop digital |
| 16 | t 180830 | 系统时间 System time |
| 17 | d 12083 I | 系统日期 System date |



















菜单结构 Menu structure

| | 主菜单 Main menu | 二级菜单 The 2 nd menu | 三级菜单 The 3 rd menu |
|---------------------------------------|---------------|--|--|
| 系统参数设定 System parameter setting | -Ad SEt- | H 000000 | 645 地址 |
| | | L 00000 I | 645 Address |
| | -nAdSEt- | nAdr 00 I | ModBus 地址 ModBus Address |
| | -Pt SEt- | ---0 I--- | 0000 I |
| | -Ct SEt- | ---0 I--- | 0000 I |
| | -bd SEt- | 02400 E | 波特率 2400, 校验位为偶校验 Baud rate 2400, check bit is even check |
| | | 02400 o | 波特率 2400, 校验位为奇校验 Baud rate 2400, check bit is odd check |
| | | 02400 n | 波特率 2400, 校验位为无校验 Baud rate 2400, check bit is no check |
| | -Cur rEu | rEuEn 0 | 电流由下侧进线, 上侧出线 (默认接法) Current from lower side incoming line, upper side outgoing line (default connection) |
| | | rEuEn 1 | 电流由上侧进线, 下侧出线 The current comes in from the upper side and comes out from the lower side |
| | -ELrEnE- | EnE 0000 (输入固定密码厂家使用) (Enter a fixed password for manufacturers to use) | SUCC (电能清零成功) SUCC (Electric energy clearing success) |
| | | | FRIL (电能清零失败) FRIL (Electric energy zeroing failure) |
| | -rtCSEt- | t 180830 | 时间 Time |
| | | d 12083 I | 日期 Date |
| -rEtUrN- | | 退出 Exit | |















3.2.4 设置查询举例 Example of setting query















3.2.4.1 PT、CT变比设置PT、CT ratio setting:

按  键进入 PSd2255“画面，通过按  键和  键改为 PSd3366, 再按  键进入，通过按  键或  键翻到“PT SET”/“CT SET”界面，再按  键进入二级菜单“---01---”，再按  键进入三级菜单“00001”，按  键或  键修改数据大小，按  键移位，在设置完成后，按  键确定退出保存，再通过  键或  键，选择 BACK，再按  键退回到主菜单，然后通过  键或  键翻到 RETURN 界面，再点  键退出。

Press  key to enter PSd2255 "screen, by  key and  key to PSd3366, press  again to enter, through  key or  key turn to "PT SET"/"CT SET" interface, press  again to enter the secondary menu "- 01 -" ,press  again to enter submenus "00001",press  key or  Key modification data size, press  key shift,After the setting is completed, press  key to confirm exit and save, then press  key or  key to select BACK, then press  key to return to the main menu, then press  key or  key to scroll to the RETURN interface, and then press  key to exit.

3.2.4.2 设备地址设置Device address setting:

按  键进入 PSd2255“画面，通过按  键和  键改为 PSd3366, 再按  键进入，通过  或  键翻到“Ad SET”界面，再按  键进入二级菜单 “L111111”，按  键或  键修改数据大小，按  键移位，在设置完成后，按  键进入“H111111”，设置完成后，按  键确定退出保存，然后通过按  键或  键翻到 RETURN 界面，再点  键退出。

Press  key to enter PSd2255 "screen, by  key and  key to PSd3366, press  again to enter, through  key or  key turn to "Ad SET" interface, press  again to enter the secondary menu "L111111",press  key or  Key modification data size, press  key shift,After the setting is completed, press  key to enter "H111111",After the setting is completed, press  key to confirm exit and save, then press  key or  key to scroll to the RETURN interface, and then press  key to exit.

第四章 技术指标 Chapter IV Technical indicators

4.1 准确度 Accuracy

0.5S 级表 Table of 0.5S class

| 电流值 Current value | 功率因素 Power factor | 基本误差 Basic error |
|------------------------------|---------------------|------------------|
| $0.01I_n \leq I < 0.05I_n$ | 1.0 | ± 1.0 |
| $0.05I_n \leq I < I_{max}$ | 1.0 | ± 0.5 |
| $0.02I_n \leq I < 0.1I_n$ | 0.5(感性 Sensibility) | ± 1.0 |
| $0.1I_n \leq I \leq I_{max}$ | 0.5(感性 Sensibility) | ± 0.6 |

1 级表 Table of 1 class

| 电流值 Current value | 功率因素 Power factor | 基本误差 Basic error |
|---------------------------|---------------------|------------------|
| $0.05I_b \leq I < 0.1I_b$ | 1.0 | ± 1.5 |
| $0.1I_b \leq I < I_{max}$ | 1.0 | ± 1.0 |
| $0.1I_b \leq I < 0.2I_b$ | 0.5(感性 Sensibility) | ± 1.5 |
| $0.2I_b \leq I < I_{max}$ | 0.5(感性 Sensibility) | ± 1.0 |

4.2 规格参数 Specification parameters (以下参数均以铭牌标注为准 the following parameters are subject to the label on the nameplate)

| | | | | | | | |
|--|--|----------|--|-----------|-----------|-----------|-----------|
| 参比电压 (Un) Reference voltage (Un) | 3×220/380V | | | | | | |
| 参比电流 Reference current | 3×1.5(6)A | 3×5(40)A | 3×5(60)A | 3×10(40)A | 3×10(60)A | 3×10(80)A | 3×20(80)A |
| 脉冲常数 imp/kWh pulse constant imp/kWh | 6400 | 800 | 400 | 800 | 400 | 400 | 400 |
| 准确度等级 Accuracy class | 有功 0.5S 级或 1 级, 无功 2 级 Active power 0.5S or level 1, reactive power level 2 | | 有功 1 级, 无功 2 级 Active power level 1, reactive power level 2 | | | | |

4.3 适用范围 Range of application

| 名称 Name | 正常工作 Normal working | 极限工作 limit working |
|--------------|----------------------|----------------------|
| 电压 Voltage | $0.9U_n \sim 1.1U_n$ | $0.7U_n \sim 1.2U_n$ |
| 频率 Frequency | 45Hz~60Hz | 45Hz~60Hz |

4.4 环境条件 Working conditions

| | |
|---------------------------------------|--|
| 环境条件 Working conditions | |
| 储藏温度 Storage temperature: -40℃~70℃ | 工作温度 Working temperature: -25℃~55℃ 极限温度 Limit working temperature: -30℃~60℃ |
| 湿度 Humidity: 20%RH~75%RH | |

4.5 功耗 Consumption

| | |
|----------------------|----------------------|
| 输入回路 Input circuit | 功耗 Consumption |
| 电压回路 Voltage circuit | ≤3VA (每相 Each phase) |
| 电流回路 Current circuit | ≤0.5VA |

备注：超过产品额定范围的电压/电流值会造成仪表损坏。长时间满量程应用也会对您的设备造成损坏。我公司对于超量程导致的精度变化不予负责。

Note: voltage/current exceeding the rated range of the product may cause instrument damage. Long full range applications can also cause damage to your equipment. Our company is not responsible for the accuracy change caused by overrange.

4.6 通讯 Communication

| | |
|---|---|
| DL/T645-2007 协议和 MODBUS-RTU 通讯协议 DL/T645-2007 protocol and MODBUS-RTU protocol | |
| 通讯端口: RS485 2 线 半双工 Communication port: RS485 2 line half duplex | 通讯波特率: 1200/2400/4800/9600/19200bps可设, 默认出厂为2400bps, 如另有要求, 请以实际产品为准 Communication baud rate: 1200/2400/4800/9600/19200bps can be set, the default factory is 2400bps, as another request, please refer to our actual product |
| 校验位: 无/奇/偶 (出厂默认偶校验), 如另有要求, 请以实际产品为准 Check bit: no/odd/even (factory default check even), if otherwise required, please refer to the actual product | 通讯地址: DL/T645-2007 通讯地址默认为电表编码 (12 位 BCD 码), 具体值可查看贴于产品上的条码纸, MODBUS 协议地址默认为 01 Mailing address: DL/T645-2007 mailing address is the meter code by default (12-bit BCD code). The specific value can be viewed from the bar code paper pasted on the product. The MODBUS protocol address is 01 by default |

4.7 电气特性 Electrical characteristics

| | |
|---------------------------------|--|
| 电气特性 Electrical characteristics | |
| 潜冲 Shunting | 当电能表施加参比电压的 115% 而电流线路无电流时, 电能表在规定的时间内测试输出不应产生多于一个的脉冲 When the watt-hour meter applies 115% of the reference voltage and there is no current in the current line, the watt-hour meter shall not generate more than one pulse in the test output within the specified time |
| 起动 Starting | 在额定电压的条件下, 负载电流升到 0.004Ib 后, 电能表在规定的时间内应有脉冲输出或代表电能输出 When the load current reaches 0.004Ib at the rated voltage, the meter shall have pulse output or power output for a specified period of time |

4.8 电磁兼容 Electromagnetic compatibility

| | |
|--|---|
| 电磁兼容 Electromagnetic compatibility | |
| 绝缘强度 Dielectric strength | 输入/地: AC4.0kV/min.1mA 输入/通讯: AC3.0kV/min.1mA Input/ground: AC4.0kV/min.1mA input/communication: AC3.0kV/min.1mA |
| 电快速瞬变脉冲群抗扰度试验 Electrical fast transient pulse group immunity test | 执行标准 GB/T 17626.4; IEC 61000-4-4 Standard GB/T 17626.4; IEC 61000-4-4 等级: IV级 (通信与输出端口 2kV, 输入端口 4kV) Level: IV level (communication with the output port 2kV, input port 4kV) |

| | |
|--|---|
| 静电放电抗扰度试验 Static discharge immunity test | 执行标准 GB/T 17626.2; IEC 61000-4-2 Standard GB/T 17626.2; IEC 61000-4-2 等级: III级 (接触放电6kV, 空气放电8kV) Level: III level (6kV, contact discharge air discharge8kV) |
| 浪涌(冲击) 抗扰度试验 Surge (shock) immunity test | 执行标准 GB/T 17626.5; IEC 61000-4-5 Standard GB/T 17626.5; IEC 61000-4-5 等级: IV级 (输入端口 4kV, 通讯与输出端口 2kV) Level: IV level (4kV, input port and output port 2kV) |
| 射频电磁场辐射抗扰度试验 Rf electromagnetic radiation immunity test | 执行标准 GB/T 17626.6; IEC 61000-4-6 Standard GB/T 17626.6; IEC 61000-4-6 等级: III级 (10V/m) Grade level: III (10V/m) |

4.9 计时准确度 Timing accuracy

计时准确度: 日计时误差 $\leq 0.5s/d(23^{\circ}C)$, 随温度变化的改变量 $< 0.15s/(d \cdot ^{\circ}C)$ 。

Timing accuracy: daily timing error acuities were $\leq 0.5s/d(23^{\circ}C)$, the amount of change with the temperature $< 0.15s/(d \cdot ^{\circ}C)$.

注: 参比温度及参比湿度: 参比温度: $23^{\circ}C \pm 2^{\circ}C$; 参比湿度: 40%~60%RH。

Note: the reference temperature and humidity of the reference: reference temperature: $23^{\circ}C$ plus or minus $2^{\circ}C$; Reference humidity: 40%~60% RH.

第五章 维护和故障排除 Chapter V Maintenance and troubleshooting

5.1 故障排除 Troubleshooting

| 可能问题 Possible problems | 可能原因 Possible cause | 可能解决方案 Possible solution |
|---|--|---|
| 上电后无显示 No display after power on | 电压输入端子压到线的绝缘层 Voltage input terminal is pressed to the insulation layer of the line | 重新接电压输入端子 Reconnect the voltage input terminal |
| 加信号后测量数据不准确或显示为0 After adding the signal, the measurement data is not accurate or displayed as 0 | 电压测量不正确 Voltage measurement is wrong | 检查电压信号是否正确接入设备 Check whether the correct voltage signal is added on the meter 检查电压测量信号是否在设备测量范围内 Check whether the voltage measuring signal is within the measuring range of the meter |
| | 电流测量不正确 Current measurement is wrong | 检查电流信号是否正确接入设备 Check whether the correct current signal is added on the meter 检查电流测量信号是否在设备测量范围内 Check whether the current measuring signal is within the measuring range of the meter |
| 上位机不能与设备通讯 The host computer cannot communicate with the device | 通讯接线不正确 The connection is not correct | 检查设备通讯线是否连接正确 Check whether the communication line of the equipment is connected correctly |
| | 通讯参数不正确 Communication parameters are incorrect | 检查通讯地址是否正确 Check if the communication address is correct 检查通讯波特率是否正确 Check if the communication baud rate is correct 检查通讯校验位是否正确 Check if the communication check bit is correct |
| | 通讯链路受影响 The communication link is affected | 检查同一个通讯链路上是否有相同参数的设备 Check whether there are devices with the same parameters on the same communication link 检查通讯屏蔽层是否良好接地 Check whether the communication shielding layer is well grounded 检查通讯电缆是否断开 Check whether the communication cable is disconnected |
| | 通讯转换设备不匹配 Communication conversion equipment does not match | 尝试换一台电脑或转接口 Try a new computer or adapter |

注：如果有一些无法解决的问题，请及时与我们公司的售后服务部门联系。

Note: If there are some problems that cannot be solved, please contact our after-sales service department in time.

第六章 质量保证 Chapter VI Quality Assurance

6.1 质量保证 Quality Assurance

所有售给用户的新仪表，在通电运行后 12 个月或收到货后 18 个月内，对其因设计、材料和工艺引起的故障实行免费质量保证，如经认定产品符合上述质保条件，我公司负责免费维修。

All new meters sold to customers shall be provided with free quality assurance for the faults caused by design, materials and process within 12 months after power-on or 18 months after receiving the goods. If the products are determined to meet the above quality guarantee conditions, our company shall be responsible for free maintenance.

6.2 质量限制 The quality of limit

以下装置的问题不属免费质保范围 Problems with the following devices are not covered by free warranty:

- 由于不正确的安装、使用、存储引起的损坏。

Damage due to incorrect installation, use, and storage.

- 超出产品规定的非正常操作和应用条件。

Excessive operating and application conditions beyond the product specifications.

- 由非本公司授权的机构或人修理了的仪表。

The meter that has been repaired by an organization or person that is not authorized by the company.

- 超出免费质保年限了的仪表。

The meter that exceeds the free warranty period.

注：以上图片仅供参考，产品以实物为准。

Note: The above pictures are for reference only, the products are subject to the actual product.



广东雅达电子股份有限公司

Guangdong Yada Electronics Co.,Ltd.

地址：广东省河源市高埔岗雅达工业园

Address:Yada industry park, Gaopugang, Heyuan city,

Guangdong Province.

国内业务 Domestic market: 86-762-3493871 3493872 3493873

国外业务 International market: 86-762-3496222

技术支持 Technical support: 86-762-3493926 3493989

传 真 Fax: 86-762-3493912 3493830

邮 编 Zip code: 517000

http: //www.yada.com.cn

E-mail: market@yada.com.cn

版权所有，保留一切权利。内容如有改动，恕不另行通知。

Copyright, all rights reserved. Specification subject to change without prior notice.