



NO: 13040503.0188.01

**DCM3366Q 电子式直流电能表**  
**DCM3366Q Electronic DC Energy Meter**

**说明书**

**Instruction**

**广东雅达电子股份有限公司**  
**Guangdong Yada Electronics Co.,Ltd.**

# 目录 Contents

<b>1. 概述 General</b> .....	<b>1</b>
<b>2. 规格及主要技术参数 Specification &amp; Main technical parameters</b> .....	<b>3</b>
2.1 规格 Specifications.....	3
2.2 技术参数 Technical parameters.....	3
2.2.1 基本误差 The basic error.....	3
2.2.2 潜动 Creeping.....	3
2.2.3 功率消耗 Power Consumption.....	4
2.2.4 工作环境条件 Working condition.....	4
2.2.5 通讯接口 Communication port.....	4
2.2.6 电磁兼容 EMC.....	4
2.2.7 机械参数 Mechanical Specifications.....	4
<b>3. 显示与操作 Display and operating</b> .....	<b>5</b>
3.1 显示方式 Display.....	5
3.2 显示功能 Display function.....	5
3.3 脉冲指示灯 Pulse indicating.....	6
<b>4. 通讯 Communication port</b> .....	<b>7</b>
4.1 通讯接口 Communication port.....	7
4.2 数据读写 Read and write data.....	7
4.3 通讯参数设置 Communication parameter setting.....	7
<b>5. 安装使用 Installation</b> .....	<b>8</b>
5.1 外形及安装 Dimension diagram and installation.....	8
5.2 端子接线图 Wiring diagram.....	8
5.3 注意事项 Note.....	9
<b>6. 储运注意事项 Transport, storage</b> .....	<b>10</b>
<b>7. 保证期限 Warranty and service</b> .....	<b>10</b>

## 1. 概述 General

DCM3366Q 型电子式直流电能表是我公司生产的新一代产品。采用液晶显示,具有 RS485 通讯功能可用与微机进行数据交换。适合蓄电池,太阳能电池板等直流信号设备电量测量和电能计量使用,亦可用于工矿企业,民用建筑,楼宇自动化等现代供配直流电系统。

DCM3366Q DC energy meter is a new type product of our company which adopts LCD display and RS485 communication with the microcomputer. It is suitable to be used for batteries, solar panels power DC signal measurement and energy metering equipment. It also can be used for industrial and mining enterprises, civil construction building automation and other modern DC system for distribution.

由测量单元、数据处理单元、通讯单元、显示单元等组成,具有电能计量、数据处理、实时监测、LCD 显示功能。电能表具有高倍过载、高精度、低功耗、停电数据自动保存、长寿命等特点。本电表符合 GB/T 33708-2017 《直流电能表技术规范》、GB/T29318-2012 《电动汽车非车载充电电能计量》相关技术标准要求。

The meter which consists of measuring unit, data processing unit, communication unit, display unit etc. has the energy measurement, data processing, real-time monitoring, LCD display function. Meanwhile, it has the characteristics of high power over load, high accuracy, low power consumption, data saving when power off, long life, etc. The meter complies with GB/T 33708-2017 "Technical specification for DC electricity meters", GB/T29318-2012 "electrical energy metering for off-board charger of electrical vehicle".

DCM3366Q 产品有多种不同型号,产品功能众多,可满足目前国内外不同场合的特殊要求。

DCM3366Q provides many different types of products which can meet domestic and international market specific requirements.

主要功能如下 Main function:

- ✧ 正反向电能单独计量,组合电能=正向+反向;

Measuring forward/reverse power energy, forward=forward+ reverse;

- ✧ 电压、电流、功率测量;

Measuring voltage, current, power;

- ✧ 上 12 个月结算电能;

Cumulative energy of the last 12 months;

- ✧ 具有日历、计时和闰年自动切换功能,具有校时功能。其中广播校时的时钟误差不得大于 5 分钟,在零点前后十分钟内不准校时,每天只允许校时一次;

It has a calendar, timing and leap year automatic switching function, having timing functions. The broadcast timing clock error shall not exceed five minutes. Do not calibrate the time between 23:50 to 00:10 in the midnight. Only allow the calibration time once a day;

- ✧ 具有两套费率时段,可通过预先设置的时间实现两套费率时段的自动切换,每套费率时段全年至少可设 2 个时区,24 小时内至少可设 8 个时段,时段最小间隔为 15 分钟,时段可跨零点设置;

There are two sets of rate period can be automatically switched by two tariff period pre-set time, the annual rate period each can be set at least two time zones can be set at least eight times in 24 hours, the minimum period interval is 15 minutes, time of day across the zero setting;

- ◇ 具有最近 10 次的编程记录和最近 10 次的校时记录;

It has recently 10 times programming records and recently 10 times of timing records;

- ◇ 调制红外通讯接口和 RS-485 通讯接口, 采用 DL/T645-2007 通讯协议和 Modbus (RTU 格式) 协议, RS485 的通讯速率可在 1200bps、2400bps、4800bps、9600bps、19200bps 设置, 调制红外的通讯速率固定为 1200bps。

Modulated infrared communication interface and RS-485 communication interface, using DL/T645-2007 communication protocol and Modbus (RTU format) protocol, RS485 communication rate can be set at 1200bps, 2400bps, 4800bps, 9600bps, 19200bps, modulated infrared communication The rate is fixed at 1200bps.

## 2. 规格及主要技术参数 Specification & Main technical parameters (以下参数均以铭牌标注为准 The following parameters are subject to the label)

### 2.1 规格 Specifications

- 准确度等级: 0.5级、1级 (以产品标示为准)

Accuracy class: 0.5class, 1class (Products subject to the actual identity)

- 额定电压 (Un): 24V、48V、100V、350V、500V、700V、750V、1000V 等

Rated voltage(Un): 24V、48V、100V、350V、500V、700V、750V、1000V so on

- 额定电流(In): 50A、100A、200A、300A、500A 等可设置 (最大测量值 7999.9999A), 支持外置 75mV 或 25mV 等规格分流器接入 (以产品标示为准)

Rated current(In): 50A、100A、200A、300A、500A etc (Customized), (The maximum measured value 7999.9999A), Support access external 75mV or 25mV and other specifications of the shunt (Products subject to the actual identity)

- 脉冲常数: 以实际铭牌标注为准

Pulse constant: subject to the nameplate label

- 辅助电源: 供电电压, AC220V/DC24V, 供电范围±20%

Power supply: Power supply voltage, AC220V/DC24V, power supply range ± 20%

### 2.2 技术参数 Technical parameters

#### 2.2.1 基本误差 The basic error

在额定电压 (Un) 下, 电能表的基本误差不应超过下表的误差极限 Under the rated voltage (Un), the basic error of the energy meter should not exceed the error limit of the following table		
负载电流 (I) 变化范围 Load current (I) variation range	误差限值 Error limit	
	0.5级 0.5class	1级 1class
$0.01I_n \leq I < 0.05I_n$	±1.0%	—
$0.02I_n \leq I < 0.05I_n$	—	±1.5%
$0.05I_n \leq I \leq I_{max}$	±0.5%	±1.0%
在额定电流 (In) 下, 电能表的基本误差不应超过下表误差极限 Under the rated current (In), the basic error of the energy meter should not exceed the error limit of the following table		
电压 (U) 变化范围 Voltage(U)variation range	误差限值 Error limit	
	0.5级 0.5class	1级 1class
$0.1U_n \leq U < 0.4U_n$	±1.0%	±1.5%
$0.4U_n \leq U < 1.3U_n$	±0.5%	±1.0%

#### 2.2.2 潜动 Creeping

在参比条件下电能表电流线路短路, 电压电路分别施加 1.1Un 和 0.8Un, 在 20min 时间内, 电能表不应有脉冲输出或代表脉冲输出的指示灯无闪烁。

Short-circuit current meter under the reference conditions, Voltage circuit are applied 1.1Un and 0.8Un, in 20min time meter should not have a pulse output or pulse output representative of light no flicker.

### 2.2.3 功率消耗 Power Consumption

电压线路 voltage line	≤1W
电流线路 current line	≤0.5W
辅助电源线路 power supply line	≤2W

### 2.2.4 工作环境条件 Working condition

工作温度范围 Working temperature range	-25℃~60℃
极限工作温度范围 Working limit temperature	-40℃~70℃
储存运输极限温度 Storage and transport limit temperature	-40℃~70℃
相对湿度 Relative humidity	<75% (年平均) <75% (annual average)

### 2.2.5 通讯接口 Communication port

通讯波特率 Communication baud rate	RS485: 1200/2400/4800/9600/19200bps 可选, 出厂默认 9600 RS485: 1200/2400/4800/9600/19200bps optional, The default baud is 9600
数据格式 Data format	O/E/N-8-1, 出厂默认 E-8-1 O/E/N-8-1, The default baud is E-8-1
通讯规约 Communication protocol	DL/T645-2007 通讯协议、Modbus-RTU DL/T645-2007 Communication protocol, Modbus-RTU

### 2.2.6 电磁兼容 EMC

绝缘强度 Insulation strength	电压/电源/外壳: 2.0kV/min voltage / Power / enclosure: 2.0kV/min 通讯/电源: 2.0kV/min communication/power supply: 2.0kV/min
静电抗扰 VESD	接触放电 8kV Contact discharge 8kV 空气放电 15kV Air discharge 15kV
电快速脉冲群抗扰性 Fast pulse group immunity	2kV
浪涌抗扰性 Surge immunity	2kV/4kV

### 2.2.7 机械参数 Mechanical Specifications

- ✧ 外型尺寸: 160± 0.5 mm (长度) × 112± 0.5 mm (宽度) × 58± 0.5 mm (厚度)  
Dimension: 160± 0.5 mm (Length) × 112± 0.5 mm (Width) × 58± 0.5 mm (Depth)
- ✧ 重量: 约 0.5kg  
Weight: about 0.5kg

### 3. 显示与操作 Display and operating

#### 3.1 显示方式 Display

电能表采用 LCD 显示信息，液晶屏可视尺寸为 60mm（长）×30mm（宽），黑字。

The meter adopts LCD display information, and the LCD screen size is 60mm (Length) ×30mm (Width) ,black.

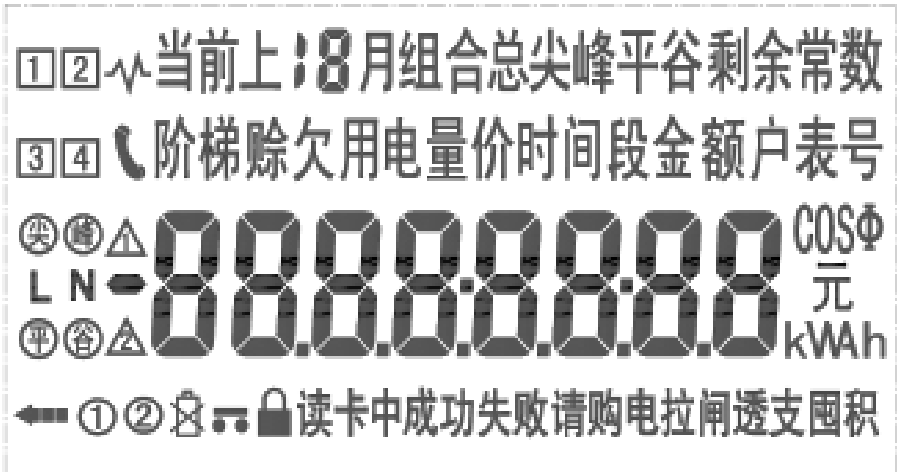

LCD 显示界面参考图 Reference image of LCD display

#### 3.2 显示功能 Display function

- ◇ 采用液晶显示，显示方式分为自动循环显示和按键显示两种，显示项目可设。

Adopting LCD display, the display style is divided to automatic cycle display and button display, display items can be set.

- ◇ 显示具有背光功能，背光为白色，可通过按键点亮，无操作 2 个自动轮显周期后自动关闭。

Display with backlight, backlight is white, can be lit by buttons and infrared, No operation shut down automatically after two auto rotate cycle.

- ◇ 可显示累计电能、电压、电流、功率、时间等信息。

It can display the information of accumulated electric energy, voltage, current, power, time, etc.

- ◇ 电能显示为 8 位，显示 2 位或 3 位小数可设，计量单位 kWh。小数位数可通过编程在 0~3 中选定。

The electric energy is displayed in 8 digits, with 2 or 3 decimal places adjustable, The measurement unit is kWh. The decimal places can be selected from 0 to 3 through programming.



## 4. 通讯 Communication port

### 4.1 通讯接口 Communication port

仪表配置有一个 RS485 通讯接口和红外通讯接口。

The meter equipped with a RS485 communication port and infrared communication port.

### 4.2 数据读写 Read and write data

通过 RS485 接口，可完成参数设置和抄读数据。兼容 DL/T 645-2007、Modbus-RTU 协议，通讯时自动识别切换，各协议实现功能分别如下：

Through RS485 port, complete parameter setting and copy to read data. Compatible DL/T645-2007, Modbus-RTU protocol, communication automatic identification switch, each protocol functions are as follows:

DL/T645-2007 协议：可读取实时电参量（电压、电流、功率等），当前有功电能及费率电能，上 12 月结算电能，事件记录数据。费率及显示设置，电表清零功能。具体参照对应协议详述。

DL/T645-2007 protocol: You can read the real-time electrical parameters (voltage, current, power, etc.), the current active energy and power tariff, 12 monthly billing electricity, event log data. Rate and display settings, meter clear function. With specific reference to the corresponding protocol in detail.

Modbus-RTU 协议：可读取实时电参量（电压、电流、功率），当前有功电能及费率电能。可设置第一套费率，电表清零功能。具体参照对应协议详述。

Modbus-RTU protocol: can be read in real time the electrical parameters (voltage, current, power), the current active energy and electricity rates. You can set the first set of rates, the meter clear function. With specific reference to the corresponding protocol in detail.

### 4.3 通讯参数设置 Communication parameter setting

通讯地址、波特率、校验位只能通过 RS485 接口设置。

Address, baud rate, parity bit which can be set through the RS485 port.

通讯地址：DL/T645-2007 协议通讯地址默认为产品编码（12 位 BCD 码），Modbus 协议地址默认为 01。

Communication address: DL/T645-2007 protocol address default to product code (12-bit BCD code), Modbus protocol address default to 01.

波特率：1200/2400/4800/9600/19200bps 可设，校验位（可设）：奇/偶/无。

Baud rate: 1200/2400/4800/9600/19200bps can be set, Parity bit (can be set): odd / even / none.

注：默认出厂为 9600bps，偶校验。校验位如另有要求，请以实际产品为准。

Note: The default baud rate is 9600bps, Parity checking. If there are other requirements, please refer to the actual product.

## 5. 安装使用 Installation

### 5.1 外形及安装 Dimension diagram and installation

电能表应安装在室内使用，安装电能表的底板应放在坚固耐火的墙上，建议安装在高度为 1.8 米左右。空气中无腐蚀性气体。电表上部有挂钩螺孔用 M4 挂钩螺钉，电表下部有 2 个安装孔用 M5×35 自攻螺钉固定在接线板上（下图）。(单位：mm，公差：±0.5)

The meter should be indoor installation; the bottom board for the meter mounting should be fixed on the wall which is fireproof and strong. The suggested mounting height is about 1.8 meters. It should not contain corrosive gases in the air. There is a screw hole suitable for M4 hook screws on the back upper of the meter, and there are two mounting holes suitable for M5×35 self-tapping screws on the back lower. (Refer to the following) (Units: mm, Tolerance:±0.5)

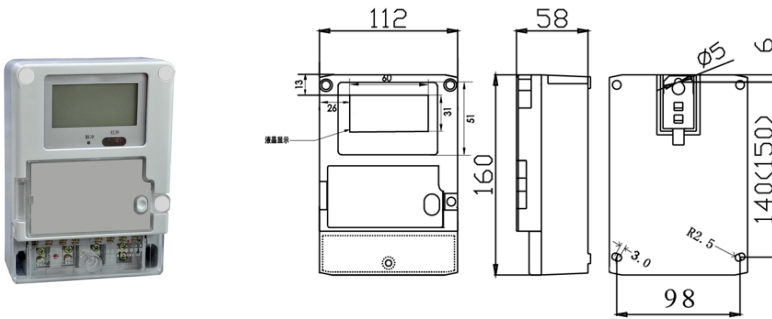

**注：以出货面板实际为准。 Note: Panel shipments to the actual subject.**

### 5.2 端子接线图 Wiring diagram

电能表应按照接线端盒上的接线图进行接线，最好用铜线或铜接线头引入。

The meter should be in accordance with the wiring diagram on the terminal box for wiring, it is best to be led in with copper wire or copper lugs. Wiring through sensor is shown below.

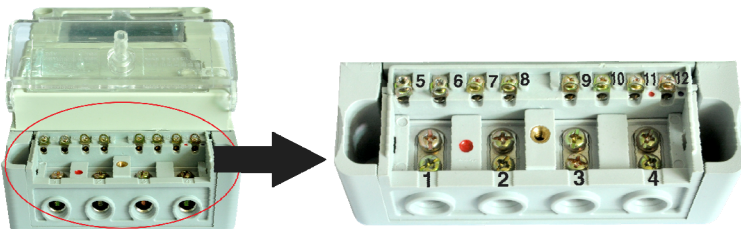

外置分流器接入接线图如下图所示：

The wiring diagram of external shunt connection:

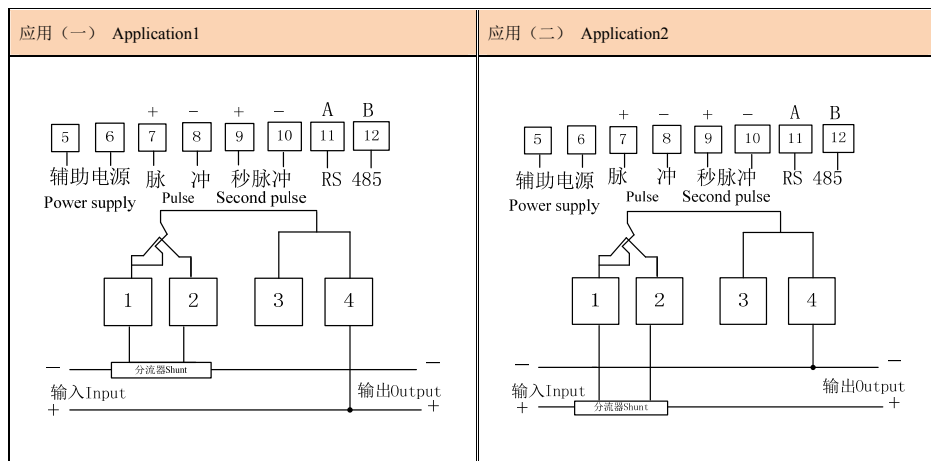

**注 Note:**

1. 当电压与电流信号全为正或负值时，功率将表示为正，计量正向电能；  
When the voltage and current signals are all positive or negative, the power will be represented as a positive, positive energy metering;
2. 当电压与电流一正一负时，功率将表示为负，计量反向电能；  
when the voltage and current positive and negative, will be represented as a negative power, reverse power measurement;
3. 当分流器在正线上时，测量电压电流为负值。  
When the shunt in the positive line, measuring voltage and current is negative.

**5.3 注意事项 Note**

电表应安装在牢固、耐火、不易振动的地方，安装后的电表应垂直不倾斜。不要私自安装电表，要按照端钮盒内接线图正确接线，否则可能因为电压过高而烧坏电表。接线时要注意因接触不良和进出线太细而引起打火和烧毁。注意电表量程，不要超过其范围，否则可能因为负载电流太大而烧坏电表。

The meter should be installed in the place of firm, fire-resistant and not easy vibration. After installation, the meter shall not incline vertical. Do not attempt to install electric meter privately. Please connect wire according to the correct wiring diagram, otherwise it may burn the meter because of the high voltage. Pay attention to the meter burning of bad contact and thin in/out line when wiring. Note the meter range, do not exceed its scope, otherwise it might because of the load current is too large to burn out the meter.

## 6. 储运注意事项 Transport, storage

6.1 产品在运输与拆封时不应受剧烈冲击，并根据国家标准 GB/T13384-2008《机电产品包装通用技术条件》的规定运输贮存。

The products should not be subject to server impact during transportation or taking down the seal, and should follow GB/T13384-2008"General Instrument packaging technology," to transport and store.

6.2 本产品属电子器件，故搬运、取放时应尽量避免重物撞击和磕碰。

This product belongs to the electronic device, should be avoided heavy impact and collision.

6.3 保存地点环境温度应为-40℃~70℃，相对湿度不超过 85%。

The ambient temperature should be -40℃~70℃ for storage, the relative humidity should be no more than 85%.

6.4 电能表应在原包装的条件下放在仓库保存，叠放高度不超过 5 箱。拆箱后的电表，如发现外观损伤，请不要对电表安装、加电；单表叠放高度不超过 5 块，拆包的电表不宜贮存。

The meter should lay under the conditions of the package, a high degree of no more than 5 stacked layers. If find the appearance of damage when unpacking, the meter should not be installed or power-on. Meter should not be stored after the package is taken down. The height of single meter stacked not more than 5 pieces.

## 7. 保证期限 Warranty and service

仪表自出厂日起 18 个月内，如用户发现不符合上述特性及技术要求，且在由有关电力计量部门证明又完全按照本说明书中所规定的要求操作的情况下，我公司负责免费维修。

Consignment within 18 months on the condition that users has follow the specified requirements of instructions and the sealed mark remain in good condition, or The Power Metering Sector provides Relevant certificates, our company are in charge for free repair.

**注：以上图片仅供参考，产品以实物为准。**

**Note: The above pictures are for reference only, the products are subject to the actual product.**



地址：广东省河源市高埔岗雅达工业园

Address: Yada industry park, Gaopugang, Heyuan city,  
Guangdong Province.

国内业务 Domestic market: 86-762-3493871 3493872 3493873

国外业务 International market: 86-762-3496222

技术支持 Technical support: 86-762-3493926 3493989 (400-830-0868)

传 真 Fax: 86-762-3493912 3493830

邮 编 Zip code: 517000

http: //www.yada.com.cn

E-mail: market@yada.com.cn

版权所有，保留一切权利。内容如有改动，恕不另行通知。

Copyright, all rights reserved. Specification subject to change without prior notice.