



NO: 13040502.0279.00

YD6600 系列智能电力测控仪
YD6600 Series of Intelligent power measurement and
control meter
使用说明书
Instruction



广东雅达电子股份有限公司
Guangdong Yada Electronics Co.,Ltd.

目 录 Contents

一、概述 GENERAL	1
二、产品规格 PRODUCT SPECIFICATIONS	1
2.1 产品功能一览表 PRODUCT FUNCTION LIST.....	1
2.2 产品测量参数 PRODUCT MEASUREMENT PARAMETERS	2
2.3 订货信息 ORDERING INFORMATION	2
三、主要技术指标 THE MAIN TECHNICAL INDEXES.....	2
四、主要功能 MAIN FUNCTION	3
4.1 电能计量 ELECTRIC ENERGY METERING	3
4.2 需量测量 DEMAND MEASUREMENT.....	4
4.3 费率和时段 RATES AND TIME PERIODS.....	5
4.4 显示功能 DISPLAY FUNCTION.....	7
4.5 瞬时测量 INSTANTANEOUS MEASUREMENT.....	7
4.6 时钟、计时功能 CLOCK AND TIMING FUNCTION.....	7
4.7 冻结功能 FREEZING FUNCTION.....	8
4.8 事件记录 EVENT RECORDS.....	11
4.9 清零 RESET.....	15
4.10 负荷记录 THE LOAD RECORD.....	16
4.11 通信功能 COMMUNICATION FUNCTION.....	17
4.12 其他功能 OTHER FUNCTIONS.....	17
五、显示说明 DISPLAY EXPLAIN	18
5.1 显示格式 DISPLAY FORMAT	18
5.2 液晶显示提示符号含义说明 DESCRIPTION OF THE LCD DISPLAY	18
六、操作说明 OPERATING INSTRUCTIONS	19
6.1 显示模式按键功能 DISPLAY MODE KEY FUNCTION	19
6.2 编程模式按键功能 PROGRAMMING MODE KEY FUNCTION.....	19
七、仪表的安装与接线 METER INSTALLATION AND WIRING.....	21
7.1 仪表安装尺寸图 METER MOUNTING DIMENSIONS	21
7.2 接线图 WIRING DIAGRAM	21
7.3 有功(校验)脉冲输出端口示意图 DIAGRAM OF ACTIVE POWER (PARITY) PULSE OUTPUT PORT	22
7.4 开关量接线 SWITCHING QUANTITY WIRING	22
八、故障对策和异常处理 FAULT COUNTERMEASURES AND EXCEPTION HANDLING	23
九、运输与存贮 TRANSPORTATION AND STORAGE	24
十、保证期限 PERIOD OF GUARANTEE	24

一、概述 General

YD6600 系列智能电力测控仪属于电能表系列，采用现代先进微电子技术、计算机技术、电测量技术及高精度计量芯片，数据通信技术以及先进的制造工艺研制而成，可测量三相电网的全部电参数，符合国家电网公司三相智能电能表技术规范的新一代电能计量装置。各项技术指标符合《GB/T 17215.323-2008》、《GB/T 17215.322-2008》、《JJG 596-2012》、《DL/T 614-2007》、《DL/T 645-2007》等国家标准以及行业标准。具有测量精度高、性能稳定可靠、长寿命、体积小、重量轻、功耗低、操作简便、易于实现管理功能的扩展、一表多用等特点。可广泛应用于电力行业的电能测量及用电自动化管理领域。

YD6600 Series of intelligent power measurement and control instrument belongs to the watt-hour meter series, using modern advanced microelectronics technology, computer technology, electrical measurement technology and high precision metering chip, data communication technology and advanced manufacturing technology development, can measure three-phase grid all electrical parameters, conform to the state grid corporation three-phase intelligent watt-hour meter technology specification of a new generation of energy metering device. The technical indicators are in line with national standards such as 《GB/T 17215.323-2008》, 《GB/T 17215.322-2008》, 《JJG 596-2012》, 《DL/T 614-2007》, 《DL/T 645-2007》 and so on. It has the characteristics of high measurement accuracy, stable and reliable performance, long life, small volume, light weight, low power consumption, simple operation, easy to realize the expansion of management function, and multiple use of one table. It can be widely used in the field of electric power measurement and power consumption automation management in the electric power industry.

二、产品规格 Product specifications

2.1 产品功能一览表 Product Function List

		型号 Model	YD6600	YD6600L	YD6600S
功能特性 Functional characteristics					
测量功能 Measurement function	电压、电流、功率、功率因数、频率 Voltage, current, power, power factor, and frequency		√	√	√
	有功、无功电能 Active and reactive electric energy		√	√	√
	分时段电能 Different period of time energy		√	√	√
	最大需量 Maximum demand		√	√	√
	失压、失流、断相、逆相序、掉电事件记录 Record of voltage loss, current loss, phase failure, reverse phase sequence, and power outage events		√	√	√
	电压、电流 21 次谐波含有率及总畸变率监测 Voltage and current 21 harmonic content rate and total distortion rate monitoring		√	√	√
通讯 Communication	RS485 通讯 RS485 Communications		√	√	√
可选配功能 Optional function	开关量输入输出 (4DI/2DO) Switching input / output (4DI/2DO)		√	√	√
	模拟量输出 (2AO) Analog output (2AO)		√	√	√

注：1. 开关量输出为常开触点；

2. 开关量输入为无源节点输入，适用于监测断路器位置信号，刀闸位置信号等状态信息；

3. 模拟量输出为 4~20mA 信号，为用户自动编程控制输出，如电压、电流、功率、电能等。

Note: 1. The switching volume output is normally open contact;

2. Switch quantity input is passive node input, which is suitable for monitoring circuit breaker position signal, switch position signal and other status information;

3. The analog output is 4~20mA signal, which automatically programs and controls the output, such as voltage, current, power, electric energy, etc.

2.2 产品测量参数 Product measurement parameters

型号 Model	类别 Sort	准确度等级 Accuracy	额定电压 Rated voltage	额定电流 Rated current	有功脉冲常数 Active pulse constant	其他 Other
YD6600	三相四线	有功: 0.2S 级 Active: 0.2S Class	3×220V/380V	3×1.5(6) A	6400(imp/kWh)	参考频率 Reference frequency 50Hz
		无功: 2 级 Reactive: 2 Class	3×57.7V/100V	3×1.5(6) A	25600(imp/kWh)	
YD6600L	Three phase four wire	有功: 0.5S 级 Active: 0.5S class	3×220V/380V	3×1.5(6) A	6400(imp/kWh)	
		无功: 2 级 Reactive: 2 class	3×57.7V/100V	3×1.5(6) A	25600(imp/kWh)	
YD6600S	三相三线 Three phase three wire	有功: 0.2S 级 Active: 0.2S class 无功: 2 级 Reactive: 2 class	3×100V	1.5(6) A	6400(imp/kWh)	

2.3 订货信息 Ordering information

订货时需注明信息 Information is required when ordering:

- 型号+参数（额定电压+额定电流）+工作电源。

Model + parameters (rated voltage + rated current) + working power supply.

- 示例: YD6600: 3×220V/380V、3×1.5(6)A、辅助电源 AC85V~265V or DC85V~330V。

Example: YD6600: 3×220V/380V, 3×1.5(6)A, power supply AC85V~265V or DC85V~330V.

- YD6600 系列带可选配功能模块，选配时注意选配的功能模块为开入（4DI）、开出（2DO）、模拟量（2AO），下单请注明。

YD6600 Series with optional function modules, optional pay attention to the optional function modules for open (4DI), open (2DO), simulated amount (2AO), order please indicate.

三、主要技术指标 The main technical indexes

技术参数 Technical parameter		指标 Indexes
准确度等级 Accuracy	电能 Energy	有功: 0.2S 级、0.5S 级; 无功: 2 级 Active power: 0.2S class, 0.5Sclass, reactive power: 2class
功能 Function	显示 Display	LCD 显示（黑底白字） LCD display (white words on black background)
	通讯 Communication	RS485 接口, Modbus-RTU 与 DLT/645-2007 协议, 波特率 1200~19200 可选; 8 个数据位 1 个停止位, 校验位可修改, 默认偶校验 RS485 Interface, Modbus-RTU and DLT/645-2007 protocol, Baud rate 1200~19200 optional, 8 data bits 1 stop bit, check bit can be modified, default parity

	指示 Indexes	DI、DO、电表故障、通讯状态等指示 Indicate of DI, DO, electricity meter failure, communication status, etc	
	开关量 Switching value	输入(4DI) Input(4DI)	无源接点输入, 仪表内置电源, 光电隔离 Passive contact input, meter built-in power supply, photoelectric isolation
		输出(2DO) Output(2DO)	常开继电器无源触点, 2A/30VDC Normally open relay passive contact, 2A / 30VDC
	模拟量 Analog quantity	2路DC4mA~20mA, 用户可编程设置 2-way DC4mA~20mA, user-programmable settings	
	时钟 Clock	参比条件下, 日计时误差小于0.5秒 In the reference condition, the daily timing error was less than 0.5s	
工作电源 Power supply	电压范围 Voltage range	AC85V~265V or DC85V~330V	
	功耗 Power consumption	≤5W	
功率消耗 Power consumption	电压回路 Voltage loop	≤1.5W、2VA (参比条件下) ≤1.5W、2VA (under the reference condition)	
	电流回路 Current circuit	≤1VA (参比条件下) ≤1VA (under the reference condition)	
工频耐压 Power frequency withstand voltage		电源端子组与信号输入端子组之间 2.2kV/1min, 与输出端子组 1.5kV/1min, 2.2kV/1min between power terminal group and signal input terminal group, 1.5kV/1min with output terminal group.	
尺寸 Size	主机 Host machine	96±0.5mm×96±0.5mm×79±0.5mm	
	开孔 Trepanning	92±0.5mm×92±0.5mm	
环境 Environment	温度 Temperature	-20℃~55℃	
	湿度 Humidity	≤95%RH, 不结露, 不含腐蚀性气体 ≤95%RH, Non-condensate, it does not contain corrosive gases	
	海拔 The sea dial	≤2500m	

四、主要功能 Main function

4.1 电能计量 Electric energy metering

- 正向有功、反向有功电能计量, 可通过软件编程实现组合有功。

Positive active energy, reverse active energy measurement, can be realized through software programming combination active power.

- 四象限无功电能计量, 可通过软件编程, 实现组合无功 1 和组合无功 2。

Four-quadrant reactive power metering can be programmed by software to achieve combined reactive power 1 and combined reactive power 2.

- 正向视在、反向视在电能计量。

Positive apparent and reverse apparent energy measurement.

- 分相有功、无功电能计量。

Phase-dependent active and reactive energy metering.

- 分时有功、无功、视在电能计量功能, 按相应的时段分别累计、存储总、尖、峰、平、谷电能。

Time-sharing active, reactive, apparent power metering function, Total, sharp, peak, flat and valley electric energy are accumulated and stored respectively according to the corresponding time period.

- 存储 12 个结算日电能数据，存储的各结算周期电能数据,各费率电能数据应为电能累计值。

The energy data of 12 settlement days shall be stored, and the energy of each settlement period and the energy data of each rate shall be the cumulative value of energy.

- 组合有功、组合无功电能的符号位由最高字节的第一个二进制位表示，0 正，1 负，因此组合有功、组合无功的数值范围变为：0.00~799999.99。对此，要求在到达极限值时进行归零处理。

The symbol bit of combined active and combined reactive power is represented by the first binary bit of the highest byte, 0 positive and 1 negative, so the numerical range of combined active and combined reactive power is changed to 0.00~799999.99.

For this reason, the zero-off processing is required when the limit value is reached.

- 电能参数不可设置底数值，只能清零。

The energy parameter cannot be set to the bottom value. It can only be cleared.

- 出厂默认设置有功组合计量方式为：正+反，无功组合计量方式 1 为：I + II,无功组合计量方式 2 为：III+IV。

The default setting of active combination measurement is: positive + reverse, reactive combination measurement mode 1 is: I + II, reactive combination measurement mode 2 is:III+IV.

有功组合方式 Active power combination mode:

BIT7	BIT6	BIT5	BIT4	BIT3	BIT2	BIT1	BIT0
保留 Keep	保留 Keep	保留 Keep	保留 Keep	反向有功 0:不减,1:减 Reverse active 0:not minus 1:minus	反向有功 0:不加,1:加 Reverse active 0: not add, 1: add	正向有功 0:不减,1:减 Positive active 0: not minus 1:minus	正向有功 0:不加,1:加 Positive active 0: not add, 1: add

无功组合方式 1、2 Reactive power combination mode 1,2:

BIT7	BIT6	BIT5	BIT4	BIT3	BIT2	BIT1	BIT0
IV 象限 0:不减,1:减 IV quadrant 0:not minus 1:minus	IV 象限 0:不加,1:加 IV quadrant 0: not add, 1: add	III 象限 0:不减,1:减 III quadrant 0: not minus 1:minus	III 象限 0:不加,1:加 III quadrant 0: not add, 1: add	II 象限 0:不减,1:减 II quadrant 0: not minus 1:minus	II 象限 0:不加,1:加 II quadrant 0: not add, 1: add	I 象限 0:不减,1:减 I quadrant 0: not minus 1:minus	I 象限 0:不加,1:加 I quadrant 0: not add, 1: add

4.2 需量测量 Demand measurement

- 正向有功、反向有功最大需量及其出现的日期和时间。

The maximum demand of positive active power and reverse active power and the date and time of their occurrence.

- 四象限无功最大需量及其出现的日期和时间。

Four-quadrant maximum reactive power demand and its occurrence date and time.

- 组合有功、组合无功最大需量及其出现的日期和时间。

The maximum demand of combined active power and combined reactive power and the date and time of their occurrence.

- 分时最大需量，即可按相应的时段分别累计、存储总、尖、峰、平、谷有功、无功最大需量及其出现的日期和时间。

The maximum demand can be accumulated according to the corresponding period, the total, total,sharp, peak, level and valley maximum demand and the date and time of occurrence.

- 最大需量可手动和命令清零：手动清需量，同时按“上翻”和“下翻”键持续 3 秒钟进行需量清零。

The maximum demand can be cleared manually and command; manually and press "Up" and "Down" for 3 seconds.

- 最大需量测量采用滑差方式，需量周期和滑差时间可设置。需量周期可在 5、10、15、30、60min 中选择；滑差式需量周期的滑差时间可以在 1、2、3、5min 中选择；需量周期应为滑差时间的 5 的整倍数。出厂默认值：需量周期 15min、滑差时间 1min。

The maximum demand measurement adopts slip mode, and the demand period and slip time can be set. The demand period can be selected in 5,10,15,30 and 60min; the slip time of the slip period can be selected in 1,2,3 and 5min; the demand period should be a multiple of 5 of the slip time. Factory default value: 15min, slip time 1min.

- 总的最大需量测量应连续进行；各费率时段最大需量的测量应在相应的费率时段内完整的测量周期内进行。

The total maximum demand measurement shall be conducted continuously; the measurement of the maximum demand in each rate period shall be conducted within the complete measurement period in the corresponding rate period.

- 当发生电压线路上电、清零、时钟调整、时段转换、需量周期变更等情况时，电能表应从当前时刻开始，按照需量周期进行需量测量；在不完整的需量周期内，不做最大需量的记录。

In case of voltage circuit charging, zero clearance, clock adjustment, time period conversion, demand cycle change, etc., the energy meter shall start from the current moment and measure the demand cycle; the maximum demand shall not be recorded during the incomplete demand period.

- 能存储 12 个结算日最大需量数据。

Can store the maximum demand data for 12 settlement days.

4.3 费率 and 时段 Rates and time periods

- 支持尖、峰、平、谷四个费率；最多有 1 个日时段表，日时段数最大为 14。

Support four rates of sharp, peak, flat and valley; up to 1 daily period table, and the maximum number of daily periods is 14.

- 年时区数最大为 14，每套时段表内最多有 8 个日时段表，日时段数最大为 14；时段最小间隔为 15 分钟，且应大于电能表内设定的需量周期；时段可以跨越零点设置。

The maximum number of annual time zones is 14, the maximum of 8 daily periods in each set of time tables, and the maximum number of daily periods is 14; the minimum time interval is 15 minutes, and should be greater than the demand period set in the electricity meter; the time period can cross the zero setting.

- 电能表内置两套时区表、两套日时段表，与之对应的还有两套时区表切换时间和两套日时段表切换时间。两套时区、时段结构关系参见示意图。

There are two built-in sets of time zone tables, two sets of day time tables, and corresponding to two sets of time zone table switching time and two sets of day time table switching time. See the schematic diagram for the relationship between the two sets of time zone and time period structures.

- 两套时区表可以任意编程，并可设定两套时区表切换时间，定时在两套时区表之间切换。

Two sets of time zone tables can be programmed arbitrarily, And can set two sets of time zone table switching time, timing to switch between the two sets of time zone tables.

- 两套日时段表可以任意编程，并可设定两套日时段表切换时间，定时在两套日时段表之间切换。

Two sets of day schedules can be programmed at will, and can set two sets of day time table switching time, regular switching between the two sets of day time table.

- Modbus 协议设置与读取为第一套时区表第一时区、第一套时段表日时段表 1。

Modbus the protocol setting and reading are the first time zone of the first set of time zone table and the day period of the first set of time table.

- 出厂默认使用第一套时区表、第一套时段表、时段费率默认为平时段。

The factory default uses the first set of time zone table, the first set of time table, and the time rate is the normal segment by default.

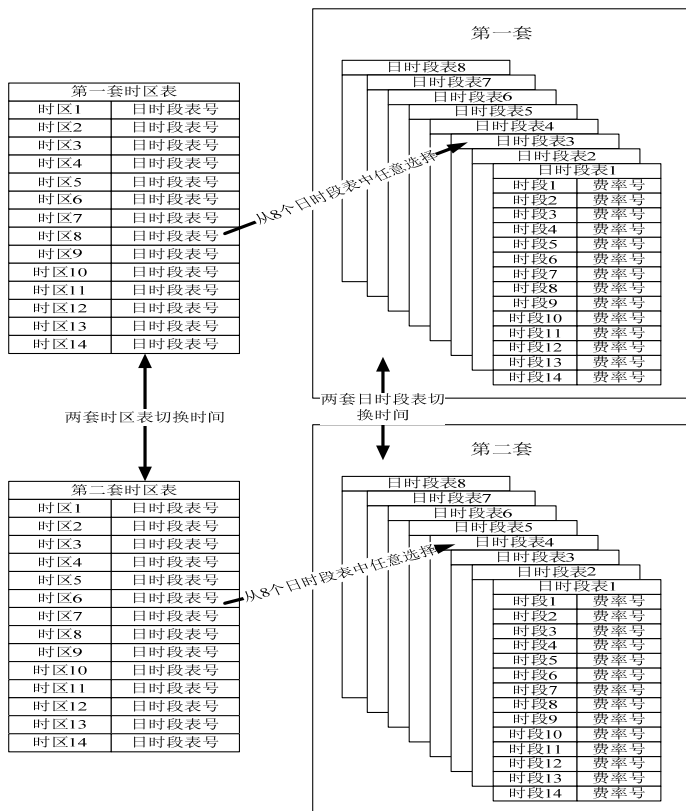

第一套时区表	The first set of time zone tables
第二套时区表	Second set of time zone tables
两套时区表切换时间	Switching time between two sets of time zone tables
从 8 个日时段表中任意选择	Choose from any of the 8 day period tables
两套日时段表切换时间	Switching time between two sets of daily time slots
日时段表号	Daily time slot number
日时段表	Daily Time Schedule
第一套	first set
第二套	second set
费率号	Rate number
时区	time zone
时段	period of time

4.4 显示功能 Display function

- 上电后，电表全屏显示 5 秒后进入自动循环显示；显示分为自动循显和按键循环显示两种方式。

After power on, display for 5 seconds; the display is divided into automatic tracking display and key cycle display.

- 在按键循环显示方式下若连续 60 秒无按键操作则返回自动循环显示方式；显示内容包括主显示数据和辅助显示代码；显示内容对应显示代码参见“操作说明”；自动循环显示时每屏显示时间为 5s。

In the key cycle display mode, the automatic cycle display mode; the display content includes main display data and auxiliary display code; for the corresponding display code of the display content, see "Operation Instructions"; the display time of each screen is 5s.

- 显示项目固定不能进行设置；循环显示和按键显示的项目参见附录 A。

Display items cannot be set; see Appendix A for items displayed in cycles and keys.

- 可显示一次测实时电参量数据。

Display real-time electrical parameter data of one time.

- 显示仪表当前通讯参数，包括仪表地址、波特率、校验位。

Displays the current communication parameters of the meter, including the address, baud rate, and parity bit.

- 具有费率状态显示指示和开关量输入输出状态显示指示。

With rate status display indication and switching input/output status display indication.

4.5 瞬时测量 Instantaneous measurement

- 测量（总/A/B/C）有功功率值、无功功率值及视在功率、瞬时功率因数。

Measure (total / A / B / C) active power value, reactive power value and apparent power and instantaneous power factor.

- 各相电压、电流有效值、相角、电网瞬时频率值测量。

Measurement of each phase voltage, the current effective value, the phase Angle, and the instantaneous frequency value of the power grid.

- 电压、电流 21 次谐波含有率及总畸变率监测，可作为参考指标用。

Voltage, current 21 harmonic content rate and total distortion rate monitoring, can be used as reference indicators.

4.6 时钟、计时功能 Clock and timing function

- 在参比温度（23℃）下，时钟准确度 $\leq \pm 0.5s/d$ ；时钟具有自动计算日历、计时、闰年自动转换功能。

At the reference temperature (23℃), the clock accuracy is $\leq \pm 0.5s/d$; the clock has the automatic calculation of calendar, timing and leap year automatic conversion function

- 只能通过通讯校时。

Only through the communication to detection time.

4.7 冻结功能 Freezing function

冻结分为定时冻结、瞬时冻结、日冻结、整点冻结；冻结方式分为广播冻结和指定冻结，广播冻结不需要从站应答。

Freezing can be divided into timing freezing, instantaneous freezing, daily freezing and hourly freezing. The freezing modes are classified into broadcast freezing and designated freezing. Broadcast freezing does not require the slave station to answer.

4.7.1 定时冻结 Time freezing

- 定时冻结可以通过两种方式中任意一种向电表下达命令，电表根据请求帧的时间进行冻结。定时冻结支持以月、日、小时为单位进行数据定期存储。

A timer freeze can be ordered in either of two ways to the meter, which freezes according to the time of the requested frame. Periodic freezing Data can be periodically stored by month, day, and hour.

- 定时冻结：按照指定的时刻、时间间隔冻结电能数据。

Time freezing: Freeze the electrical energy data at the specified time and interval.

- 一次定时冻结数据项包括定时冻结时间、正向有功电能、反向有功电能、组合无功 1 电能、组合无功 2 电能、一象限无功电能、二象限无功电能、三象限无功电能、四象限无功电能、正向有功最大需量及发生时间、反向有功最大需量及时间、瞬时数据（总、ABC 相有无功功率）。

One time timing freeze data items include timing freeze time, forward active power, reverse active power, combined reactive power 1, combined reactive power 2, one-quadrant reactive power, two-quadrant reactive power, three-quadrant reactive power, four-quadrant reactive power, forward active maximum demand and occurrence time, reverse active maximum demand and time, and instantaneous data (total and ABC are present or not) Power.

- 记录最近 12 次定时冻结数据。

Record the last 12 time-frozen data.

- 定时冻结参考 DL/T645-2007，命令数据域：MMDDhhmm(月.日.时.分)意义为 99DDhhmm 表示以月为周期定时冻结，9999hhmm 表示以日为周期定时冻结，999999mm 表示以小时为周期定时冻结。

Time freeze reference DL/T645-2007, Command data field: MMDDhhmm(Month, day, hour, minute) Meaning 99DDhhmm indicates periodic freezing in a month period. 9999hhmm indicates a periodic freeze on a daily basis, 999999mm freezes at intervals of hours.

- 定时冻结的数据项可以通过设置定时冻结特征字来冻结数据。冻结字的缺省值为 FF。

Timed frozen data items can freeze the data by setting the timing freeze feature character. The default value of the frozen word is FF.

- 定时冻结特征字（0 代表不记录此项数据，1 代表记录此项数据）。

Periodic freeze signature (0 indicates that this data is not recorded, and 1 indicates that this data is recorded).

BIT7	BIT6	BIT5	BIT4	BIT3	BIT2	BIT1	BIT0
变量 variable	反向有功最大需量及发生时间 Maximum demand and occurrence time of reverse active power	正向有功最大需量及发生时间 Maximum demand and occurrence time of positive active power	四象限无功电能 Four-quadrant reactive energy	组合无功 2 电能 Combined reactive power 2 energy	组合无功 1 电能 Combined reactive power 1 energy	反向有功电能 Reverse active energy	正向有功电能 Positive active energy

4.7.2 瞬时冻结 Instantaneous freezing

- 瞬时冻结是主站向电表下达冻结命令，且主站请求时间为 99999999。

The instantaneous freezing is the main station to the meter, and the main station request time is 99999999.

- 瞬时冻结：在非正常情况下，冻结当前的日历、时间、所有电量和重要测量量的数据。

Instantaneous freezing: Under abnormal conditions, freeze the current calendar, time, all electrical energy and important measurements.

- 一次瞬时冻结数据项包括瞬时冻结时间、正向有功电能、反向有功电能、组合无功 1 电能、组合无功 2 电能、一象限无功电能、二象限无功电能、三象限无功电能、四象限无功电能、正向有功最大需量及发生时间、反向有功最大需量及发生时间、瞬时数据（总、ABC 相有无功功率）。

A transient freezing data item includes a transient freezing time, a transient freezing time, a transient freezing time, reverse active power, combined reactive 1 energy, combination of reactive 2 energy, a quadrant reactive energy, two quadrant reactive energy, three quadrant reactive energy, four quadrant reactive energy, positive active maximum demand and occurrence time, reverse active maximum demand and occurrence time, instantaneous data (total, ABC phase reactive power).

- 记录最近 3 次瞬时冻结数据。

Record the last 3 instantaneous frozen data.

- 瞬时冻结一般是主站认为需要冻结当前数据才下发的。瞬时冻结可以用于多个计量点的同时电量冻结和数据抄读，便于进行电网线损、电量平衡分析。（瞬时冻结命令下发时无须按下编程键）。

Instantaneous freezing is generally issued only when the main station believes that it needs to freeze the current data. Instantaneous freezing can be used for the simultaneous power freezing and data reading of multiple metering points, which facilitates the analysis of power grid line loss and power balance. (There is no need to press the programming button when the instantaneous freezing command is issued).

- 瞬时冻结的数据项可以通过设置瞬时冻结特征字来冻结。特征字缺省 FF。

Instantaneous frozen data items can be frozen by setting the instantaneous frozen feature word. The feature character is the default FF.

- 瞬时冻结特征字（0 代表不记录此项数据，1 代表记录此项数据）。

Instantaneous freeze feature word (0 indicates that this data is not recorded, 1 indicates that this data is recorded).

BIT7	BIT6	BIT5	BIT4	BIT3	BIT2	BIT1	BIT0
变量 variable	反向有功最大需量及发生时间 Maximum demand and occurrence time of reverse active power	正向有功最大需量及发生时间 Maximum demand and occurrence time of positive active power	四象限无功电能 Four-quadrant reactive energy	组合无功 2 电能 Combined reactive power 2 energy	组合无功 1 电能 Combined reactive power 1 energy	反向有功电能 Reverse active energy	正向有功电能 Positive active energy

4.7.3 整点冻结 Hour freezing

- 整点冻结：存储整点时刻或半点时刻的有功总电能。

Hour freezing: Store the total active energy at the hour or half hour.

- 一次整点冻结数据项包括整点冻结时间、正向有功总电能、反向有功总电能。

The data items of hour freezing include the hour freezing time, positive active total energy, and reverse active total energy.

- 为满足整点冻结要求，DL/T 645-2007 备案文件中增加整点冻结起始时间和整点冻结时间间隔两个参数，整点冻结时间默认 60 分。

In order to meet the requirements of freezing on the hour, two parameters of freezing start time and freezing interval are added to the DL/T 645-2007 filing, the default freezing interval on the hour is 60 minutes.

- 通过设置整点冻结起始时间来开启整点冻结功能。

Enable the hour freezing function by setting the hour freezing start time.

- 通过设置整点冻结时间间隔分为两种

There are two kinds of freezing time interval by setting the hour.

- 整点冻结方式，一种为整点冻结时间间隔为 60 分钟的整点时刻冻结，另一种整点冻结时间间隔 30 分钟的整点时刻和半点时刻冻结。

Freezing at the hour. One method is freezing at the hour with an interval of 60 minutes; the other method is freezing at the hour and half at the hour with an interval of 30 minutes.

- 记录 255 个整点冻结数据。

255 frozen data points were recorded.

- 整点冻结的电能数据项可以通过设置整点冻结特征字来确定要冻结的数据，整点冻结特征字缺省为 3。

The electric energy data item frozen on the hour can be used to determine the data to be frozen by setting the hour freezing feature word, and the hour freezing feature word is 3.

- 整点冻结特征字（0 代表不记录此项数据，1 代表记录此项数据）。

Hour freeze feature (0 indicates that this data is not recorded, 1 indicates that this data is recorded).

BIT7	BIT6	BIT5	BIT4	BIT3	BIT2	BIT1	BIT0
保留 Keep	保留 Keep	保留 Keep	保留 Keep	保留 Keep	保留 Keep	反向有功电能 Reverse active energy	正向有功电能 Positive active energy

4.7.4 日冻结 Day freezing

- 日冻结：每天零点冻结当前的日历、时间、所有电能量和重要测量量的数据。

Daily freeze: The current calendar, time, all electrical energy and important measurements are frozen at zero every day.

- 一次日冻结数据项包括瞬时冻结时间、正向有功电能、反向有功电能、组合无功 1 电能、组合无功 2 电能、一象限无功电能、二象限无功电能、三象限无功电能、四象限无功电能、正向有功最大需量及发生时间、反向有功最大需量及发生时间、瞬时数据（总、ABC 相有无功功率）。

A day frozen data items including instantaneous freezing time, positive active power, reverse active power, combined reactive power 1, combination 2 reactive power, a quadrant reactive power, two quadrant reactive power, three quadrant reactive power, four quadrant reactive power, positive active maximum demand and occurrence time, reverse active maximum demand and occurrence time, instantaneous data (total, ABC phase reactive power).

- 记录最近 62 次日冻结数据。

Record the last 62 frozen data.

- 为满足规约要求，DL/T 645-2007 备案文件中增加日冻结时间，默认冻结时间为 00 时 00 分。

In order to meet the regulatory requirements, the daily freezing time is added in the DL/T 645-2007 record documents, and the default freezing time is 00:00.

- 通过设置日冻结时间，可以存储每天任意时刻的所有电能和重要测量量的数据。

By setting the daily freeze time, you can store all electricity and important measurements at any time of the day.

- 日冻结的数据项可以通过设置日冻结特征字来确定。日冻结特征字缺省为 FF。

Daily frozen data items can be determined by setting the daily frozen trait character. The daily freeze feature word default is FF.

- 日冻结特征字（0 代表不记录此项数据，1 代表记录此项数据）。

Daily frozen feature word (0 indicates that this data is not recorded,1 indicates that this data is recorded).

BIT7	BIT6	BIT5	BIT4	BIT3	BIT2	BIT1	BIT0
变量 variable	反向有功最大需求量及 发生时间 Maximum demand and occurrence time of reverse active power	正向有功最大需求量 及发生时间 Maximum demand and occurrence time of positive active power	四象限无功电 能 Four-quadrant reactive energy	组合无功 2 电能 Combined reactive power 2 energy	组合无功 1 电能 Combined reactive power 1 energy	反向有功 电能 Reverse active energy	正向有功 电能 Positive active energy

4.8 事件记录 Event Records

4.8.1 失压记录 Voltage loss record

- 起始条件：某相电压小于 NNN.NV(失压事件电压触发上限，可设)，同时该相电流大于 NN.NNNNA(失压事件电流触发下限，可设)。

Starting condition: The voltage of a phase is less than NNN.NV (the upper voltage trigger limit can be set), and the phase current is greater than NN.NNNNA (the lower limit of the voltage loss event current trigger, can be set).

- 结束条件：电压大于 NNN.NV(失压事件电压触发下限)或电流小于 NN.NNNNA(失压事件电流触发下限)。

Ending condition: Voltage is greater than NNN. NV (Lower threshold of voltage trigger for voltage loss event) or current is less than NN. NNNNA (voltage loss event current trigger limit).

- 判定延时：可设(失压事件判定延时时间)。

Judgment delay time: can be set (voltage loss event judgment delay time).

- 参考 DL/T 645-2007 备案文件中的失压参数，判定指标规定如下：

Referring to the pressure loss parameters in the DL/T 645-2007 filing documents, the determination indicators are specified as follows:

- 失压事件电压触发上限，默认 78%Un。

Loss event voltage trigger upper limit, default 78%Un.

- 失压事件电压恢复下限，默认 85%Un。

Loss event voltage recovery lower limit, default 85%Un.

- 失压事件电流触发下限，对应此处“启动电流”，默认 0.5%Ib。

Pressure loss event current trigger limit, corresponding to "start current", default 0.5% Ib.

- 失压事件判定延时时间，默认 60 秒。

Loss loss event judgment delay time, default 60 seconds.

- 失压记录包括 A 相失压记录、B 相失压记录和 C 相失压记录。

Voltage loss records include A phase voltage loss records, B phase voltage loss records, and C phase voltage loss records.

- A 相一次失压记录包括 A 相失压发生时刻和 A 相失压发生时刻时的正向有功电能、反向有功电能、组合无功 1 电能、组合无功 2 电能、ABC 相正向有功电能、ABC 相反向有功电能、ABC 相组合无功 1 电能、ABC 相组合无功 2 电能、ABC 相电压、ABC 相电流、ABC 相有功功率、ABC 相无功功率、ABC 相功率因数、A 相失压期间总安时数、ABC 相安时数及 A 相失压结束时刻和 A 相失压结束时刻时的正向有功总电能、反向有功总电能、组合无功 1 和 2 总电能、ABC 相正向有功电能、ABC 相反向有功电能、ABC 相组合无功 1 和 2 电能。

Primary pressure loss record of A phase includes forward active power and A phase voltage loss, reverse active energy,

combined reactive energy 1, combined reactive energy 2, ABC phase positive active energy, ABC phase reverse active energy, ABC phase combination reactive energy 1, ABC phase combination reactive energy 2, ABC phase voltage, ABC phase current, ABC phase active power, ABC phase reactive power, ABC phase power factor, total ampere hours during A phase voltage loss, ABC phase voltage loss, forward active power during the end of A phase and the end of A phase Energy, combined reactive energy 1 and 2, ABC phase positive active energy, ABC phase negative active energy, and ABC phase combined reactive energy 1 and 2

- 记录 A 相失压总次数、A 相失压总累计时间和最近 10 次 A 相失压记录。
The total number of phase A losses, the total cumulative time of phase A losses and the last 10 phase A losses were recorded.
- BC 相失压记录同上。
The BC phase pressure loss recording is the same as above.
- 当“失压事件电压触发上限”设定为“0”，则不启用失压事件判定。
When the voltage trigger upper limit is set to "0", the voltage loss event determination is not enabled.

4.8.2 失流记录 current loss recording

- 起始条件：三相中至少一相电流大于 NN.NNNNA(失流事件电流触发下限，可设)，某相电流小于 NN.NNNNA(失流事件电流触发上限，可设)，该相电压都大于 NNN.NV(失流事件电压触发下限，可设)。
Starting condition: at least one phase of the three-phase current is greater than NN. NNNNA (lower limit of lost event current triggering, be set), the current of a phase is less than NN. NNNNA (lost event current trigger upper limit, can be set), the phase voltage is greater than NNN. NV (lost current event voltage trigger lower limit, setting).
- 结束条件：该相电流大于 NN.NNNNA(失流事件电流触发上限)或电压小于 NNN.NV(失流事件电压触发下限)或三相电流都小于 NN.NNNNA(失流事件电流触发下限)。
End condition: the phase current is greater than NN. NNNNA (lost event current trigger upper limit) or voltage less than NNN. NV (voltage trigger limit) or three-phase current is less than NN. NNNNA (current event current trigger limit).
- 判定延时：可设（失流事件判定延时时间）。
Judgment delay: can be set (lost event judgment delay time).
- 参考 DL/T 645-2007 备案文件中失流参数，判定指标规定如下：
Refer to the loss parameters in the DL/T 645-2007, the determination indicators are as follows:
- 失流事件电压触发下限，默认 60%Un。
Lower limit for triggering the loss current. The default value is 60%Un.
- 失流事件电流触发上限，默认 5%Ib。
Upper limit for triggering the loss current. The default value is 5%Ib.
- 失流事件电流触发下限（对应失流判定时其它相的负荷电流限值），对应此处“启动电流”。
The lower limit of lost event current trigger (corresponding to the load current limit of other phases in the decision of flow loss), corresponding to the "start current".
- 失流事件判定延时时间，默认 60 秒。
Loss event determination delay time, The default value is 60 seconds.
- 失流记录包括 A 相失流记录、B 相失流记录和 C 相失流记录。
Flow loss records include A phase, B phase and C phase.
- A 相一次失流记录包括 A 相失流发生时刻和 A 相失流发生时刻时的正向有功电能、反向有功电能、组合无功 1 电能、

组合无功 2 电能、ABC 相正向有功电能、ABC 相反向有功电能、ABC 相组合无功 1 电能、ABC 相组合无功 2 电能、ABC 相电压、ABC 相电流、ABC 相有功功率、ABC 相无功功率、ABC 相功率因数及 A 相失流结束时刻和 A 相失流结束时刻时的正向有功总电能、反向有功总电能、组合无功 1 和 2 总电能、ABC 相正向有功电能、ABC 相反向有功电能、ABC 相组合无功 1 和 2 电能。

A phase primary lost current records including forward active power, and A phase current loss occurred, reverse active power, combined reactive power, combined reactive power, combined reactive 2 positive active power, ABC phase, ABC, ABC phase combination reactive power, ABC phase voltage, ABC phase current power, ABC phase active power, ABC phase reactive power, ABC phase power factor and positive total active power and A phase, reverse total active power, combined reactive 1 and 2, ABC phase positive Active power, ABC are opposite to active power and ABC combine reactive power 1 and 2.

- 记录 A 相失流总次数、A 相失流总累计时间和最近 10 次 A 相失流记录。

The total number of phase A losses, the total cumulative time of phase A losses, and the last 10 phase A losses were recorded.

- BC 相失流记录同上。

BC phase loss recording record same as above.

- 当“失流事件电流触发上限”设定为“0”，则不启用失流事件判定。

When Trigger Upper Limit for Blackout Event current is set to 0, the blackout event determination is disabled.

4.8.3 断相记录 Phase break recording

- 起始条件：该相电压小于 $NNN.NV$ (断相事件电压触发上限，可设)，电流小于 $NN.NNNNA$ (断相事件电流触发上限，可设)。

Starting condition: The phase voltage is less than $NNN.NV$ (upper limit of voltage trigger, set), current less than $NN.NNNNA$ (breaking phase event current trigger upper limit, be set).

- 结束条件：该相电压大于 $NNN.NV$ (断相事件电压触发上限)，或电流大于 $NN.NNNNA$ (断相事件电流触发上限)。

End condition: the phase voltage is greater than $NNN.NV$ (phase breaking event voltage trigger upper limit), or the current is greater than $NN.NNNNA$ (upper limit of the phase-breaking event current trigger).

- 判定延时：可设(断相事件判定延时时间)。

Decision delay: can be set (broken phase event judgment delay time).

- 参考 DL/T 645-2007 备案文件中断相参数，判定指标规定如下：

Refer to the interruption phase parameters of DL/T 645-2007, the determination indicators are as follows:

- 断相事件电压触发上限，默认 $60\%U_n$ 。

Phase break event voltage trigger upper limit, default $60\%U_n$.

- 断相事件电流触发上限，默认 $0.5I_b$ 。

Break phase event current trigger upper limit, default $0.5I_b$.

- 断相事件判定延时时间，默认 60 秒。

Phase-breaking event judgment delay time, default 60 seconds.

- 断相记录包括 A 相断相记录、B 相断相记录和 C 相断相记录。

Broken phase recording includes A phase recording, B phase recording and C phase recording.

- 相一次断相记录包括 A 相断相发生时时刻和 A 相断相发生时时刻的正向有功电能、反向有功电能、组合无功 1 电能、组合无功 2 电能、ABC 相正向有功电能、ABC 相反向有功电能、ABC 相组合无功 1 电能、ABC 相组合无功 2 电能、ABC 相电压、ABC 相电流、ABC 相有功功率、ABC 相无功功率、ABC 相功率因数及 A 相断相结束时刻和 A 相断相结束时

刻时的正向有功总电能、反向有功总电能、组合无功 1 和 2 总电能、ABC 相正向有功电能、ABC 相反向有功电能、ABC 相组合无功 1 和 2 电能。

Phase primary phase breaking record includes forward active power, reverse active power, combined reactive power 1, combined reactive active power 2, ABC phase, ABC phase combined reactive power 1, ABC phase combined reactive power 2, ABC phase voltage, ABC phase current, ABC phase active power, ABC phase reactive power, and positive total active power and A, ABC phase Active power and ABC are opposite to active power and ABC phase combine reactive power 1 and 2.

- 记录 A 相断相总次数、A 相断相总累计时间和最近 10 次 A 相断相记录。

Record the total number of A phases, the total cumulative time of A phases and the last 10 A phase records.

- BC 相断相记录同上。

The BC phase fracture recording is the same as above.

- 当“断相事件电压触发上限”设定为“0”，则不启用断相事件判定。

When the upper limit is set to 0, the event determination is not enabled.

4.8.4 电压逆相序记录 Voltage reverse phase sequence recording

- 起始条件：电压逆相序发生，且三相电压都大于临界电压。

Starting condition: the voltage reverse phase sequence occurs, and the three-phase voltage is greater than the critical voltage.

- 结束条件：电压逆相序结束或电压小于临界电压。

End condition: the voltage reverse phase sequence end or the voltage is less than the critical voltage.

- 判定延时：60 秒。

Decision delay: 60 seconds.

- 一次电压逆相序记录包括电压逆相序发生时刻、电压逆相序发生时的正向有功总电能、反向有功总电能、组合无功 1 总电能、组合无功 2 总电能、ABC 相正向有功电能、ABC 相反向有功电能、ABC 相组合无功 1 电能、ABC 相组合无功 2 电能、电压逆相序结束时刻和电压逆相序结束时的正向有功总电能、反向有功总电能、组合无功 1 总电能、组合无功 2 总电能、ABC 相正向有功电能、ABC 相反向有功电能、ABC 相组合无功 1 电能、ABC 相组合无功 2 电能。

A voltage reverse phase sequence record including voltage reverse phase sequence, reverse total active power, total active power, combined reactive power, combined reactive power 2 total power, ABC phase positive active power, ABC opposite to active power, ABC phase combination reactive power, voltage reverse total active power and the end of the reverse active total active power, combined reactive power, ABC phase positive active power, ABC opposite to active power, ABC phase combined reactive power 1, A The BC phase combination of reactive power 2 electric energy.

- 记录电压逆相序次数、电压逆相序总累计时间和最近 10 次电压逆相序记录。

Record the voltage reverse phase order, the total cumulative time of voltage reverse phase order and the last 10 voltage reverse phase order.

4.8.5 电流逆相序记录 Current reverse phase sequence recording

- 起始条件：电流逆相序发生且三相电压都大于临界电压且三相电流都大于 5% 额定电流。

Starting condition: the current reverse phase sequence occurs and the three phase voltage is greater than the critical voltage and the three phase current is greater than 5% of the rated current.

- 结束条件：电流逆相序结束或电压小于临界电压或电流小于 5% 额定电流。

End condition: current reverse phase sequence end or voltage is less than the critical voltage or current is less than 5% of the rated current.

- 判定延时：60 秒。

Decision delay: 60 seconds.

- 一次电流逆相序记录包括电流逆相序发生时刻、电流逆相序发生时的正向有功总电能、反向有功总电能、组合无功 1 总电能、组合无功 2 总电能、ABC 相正向有功电能、ABC 相反向有功电能、ABC 相组合无功 1 电能、ABC 相组合无功 2 电能、电流逆相序结束时刻和电流逆相序结束时的正向有功总电能、反向有功总电能、组合无功 1 总电能、组合无功 2 总电能、ABC 相正向有功电能、ABC 相反向有功电能、ABC 相组合无功 1 电能、ABC 相组合无功 2 电能。

A current reverse phase sequence record including current reverse phase sequence occurrence moment, current reverse phase sequence, reverse total active power, reverse active power 1 total power, combined reactive power, combined reactive 2 total active power, ABC phase reverse positive active power, ABC to active power, ABC phase combined reactive power, ABC phase combined reactive power, current reverse total active power and the end of the reverse active total power, combined reactive power, ABC phase positive active power, ABC opposite to active power, ABC phase combined reactive power 1, A The BC phase combination of reactive power 2 electric energy.

- 记录电流逆相序次数、电流逆相序总累计时间和最近 10 次电流逆相序记录。

The current reverse phase order times, the total cumulative time and the last 10 current reverse phase sequence are recorded.

4.8.6 需清记录 Records to be cleared

- 一次需清记录包括需清的时刻、操作都代码和需量清零前的所有最大需量及发生时间。

One clearance record includes the clearance time, operation code and all the maximum demand and occurrence time before the demand clearance

- 记录需清总次数和最近 10 次需清记录。

The total number of records and the last 10 records.

4.8.7 校时记录 Time correction record

- 一次校时记录包括操作者代码、校时前时间和校时后时间。

A school time record includes the operator code, pre-school time and post-school time.

- 记录校时总次数（不包含广播校时）和最近 10 次校时记录。

Record the total number of school times (excluding broadcast school times) and the last 10 school times.

4.8.8 掉电记录 Loss power record

- 掉电记录包括掉电发生时刻、结束时刻。

The power loss record includes the time and end of the power loss.

- 记录掉电总次数和最近 10 次掉电记录。

Record the total number of power drops and the last 10 power drops.

4.9 清零 Reset

清零分电表清零、最大需量清零、事件清零三种，可分别进行操作。其中电表清零操作不包括电表清零事件的所有记录数据。事件清零可以清除某类或全部事件记录(除电表清零和事件清零之外的记录)。

There are three kinds of meter clearing, maximum demand clearing and event clearing, which can be operated separately. The meter zero clearing operation does not include all the recorded data of the meter zero clearing event. Event clearing can clear some or all event records (except for meter clearing and event clearing).

4.9.1 电表清零 Meter reset

- 清除电能表内存储的电能量、最大需量、冻结量、事件记录、负荷记录等数据。
Clear the electrical energy, maximum demand, freezing amount, event record, load record and other data stored in the electric energy meter.
- 电表清零必须记录清零时刻和清零前的电能量。
The electrical energy at the time and before the meter must be recorded.
- 当电表正在进行清零时，液晶提示： $\bar{n}E\bar{t}-\bar{C}Lr$ ，直到清零操作完成，液晶进入正常的显示。
 $\bar{n}E\bar{t}-\bar{C}Lr$ When the meter is clearing zero, the LCD prompts: until the zero clearance operation is completed, the LCD enters the normal display.
- 电表清零命令的密码权限只能为 02。
The password permission for the meter reset command can only be 02.

4.9.2 需量清零 Demand clearing

- 清空电能表内当前的最大需量及发生的日期、时间等数据。
Empty out the current maximum demand in the electricity meter, the date, time of occurrence and other data.
- 需量清零必须记录清零时刻以及清零前最大需量及发生时间。
Record the demand clearing time and the maximum demand and occurrence time before the demand clearing.
- 当电表进行需清时，液晶显示为： $dE\bar{n}-\bar{C}Lr$ ，直到需清操作完成，液晶进入正常显示。
 $dE\bar{n}-\bar{C}Lr$ When the electricity meter needs to be cleared, the liquid crystal display is: until the clear operation is completed, the liquid crystal enters the normal display.
- 需量清零的密码权限可以为 02 或 04。
The password permission for the requirement reset can be 02 or 04.

4.9.3 事件清零 Event clearing

- 清空电能表内的所有事件记录。
Empty all event records in the energy meter.
- 事件清零必须记录清零时刻、操作者代码、事件清零数据标识。
Event zero clearance must record the zero clearance time, operator code, and event zero clearance data identification.
- 当电能表进行事件清零时，液晶显示： $E\bar{u}t-\bar{C}Lr$ 直到事件清零操作完成，液晶退出该提示，进入正常显示。
 $E\bar{u}t-\bar{C}Lr$ When the electricity meter is event zero, the liquid crystal display: until the event clearing operation is completed, the liquid crystal exits the prompt and enters the normal display.
- 事件清零的密码权限只能为 02。
The password permission for event zero is only 02.

4.10 负荷记录 The load record

- 负荷记录内容可以从 DL/T 645-2007 定义的“电压、电流、频率”、“有、无功功率”、“功率因数”、“有、无功总电能”、“四象限无功总电能”、“当前需量”六类数据项中任意组合。
The load record content can be defined from DL/T 645-2007 ", voltage, current, frequency", "have, reactive power", "power factor", "power factor", "have, reactive power", "four quadrant reactive power", "current demand" six categories, any combination of data items.

- 负荷记录间隔时间可以在 1~60 分钟范围内设置，每类负荷记录的时间间隔可以相同，也可以不同。
The load recording interval time can be set in the range of 1 to 60 minutes, and the time interval of each type of load recording can be the same or different
- 负荷记录存储空间保证在记录正反向有功总电能、无功总电能、四象限无功总电能，时间间隔为 1 分钟的情况下可记录不少于 40 天的数据容量。
The load recording storage space ensures that the data capacity of no less than 40 days can be recorded for the total positive and negative active power, total reactive power and four quadrants with a time interval of 1 minute.
- 负荷曲线保存的时刻与电表时钟同步，保存数据的时刻是根据设置的 6 类数据记录间隔与电表时钟的关系确定的，保存数据的间隔时间最小为 1 分钟。电表对 6 类数据分别以对应的负荷记录间隔时间为周期进行保存。
The time when the load curve is saved is synchronized with the meter clock, and the time when saving data is determined according to the relationship between the six types of data recording interval and the meter clock. The interval time when keeping data at the minimum is 1 minute. The meter saves the data of 6 categories with the corresponding load recording interval.
- 每类和总负荷记录分为 3 种读取方式：最早记录块，给定时间记录块，最近一个记录块。
Each class and total load record are divided into three reading methods: the earliest recording block, the given time recording block, and the latest recording block.

4.11 通信功能 Communication function

- 仪表具有 1 个 RS485 通信接口，通信接口与电能表内部电路实行电气隔离，有失效保护电路。
The instrument has an RS485 communication interface, which is electrical isolated from the internal circuit of the electricity meter and has a failure protection circuit.
- RS485 通讯波特率在 1200bps、2400bps、4800bps、9600bps、192000 bps 可设，出厂默认为 2400bps。
RS485 communication wave rate in 1200bps, 2400bps, 4800bps, 9600bps, 192000bps, the factory default is 2400bps.
- 可现场对通讯参数进行修改设置，包括仪表地址、波特率、校验位。
Communication parameters can be modified on site, including instrument address, port rate and check bit.
- 通信遵循 Modbus-RTU 协议与 DL/T 645-2007 协议及其备案文件。
The communication follows the Modbus-RTU protocol and the DL/T 645-2007 protocol and its filing documents.
- DL/T 645-2007 协议通讯地址默认为电表序列条码，Modbus 协议地址默认为 01，可通过按键和通讯修改。
DL/T 645-2007 protocol communication address is the electricity meter sequence bar code by default, and Modbus protocol address is 01 by default, which can be modified by button pressing and communication.

4.12 其他功能 Other functions

- 有功脉冲输出，脉冲宽度为 80ms±20ms 电脉冲经光电隔离后输出。
The active pulse output, pulse width of 80 ms± 20ms electric pulse output after photoelectric isolation.
- 四路无源节点输入（DI1、DI2、DI3、DI4），适用于监测断路器位置信号，刀闸位置信号等状态信息。
Four-way passive node input (DI1, DI2, DI3, DI4), suitable for monitoring circuit breaker position signal, switch position signal and other state information.
- 两路常开继电器无源触点遥控输出(DO1、DO2)，电源掉电时继电器复归为常开状态。
Remote control output of two passive contacts (DO1, DO2), and the relay returns to the normally open state when the power supply drops.
- 两路模拟量 DC4mA~20mA 输出，为用户自动编程控制输出，如电压、电流、功率、电能等，连接上位机设置。
Two analog capacity DC4mA~20mA output, for users to automatically program and control the output, such as voltage, current, power, electric energy, etc, connect to the upper computer setting.

五、显示说明 Display explain

5.1 显示格式 Display format

仪表采用 LCD 显示信息；液晶屏可视尺寸为 64mm（长）×49mm（宽）；LCD 显示的内容参见图 5-1；图中各图形、符号的说明参见表 4-1；不同类型电能表可以根据需要选择相应的显示内容。

The instrument adopts LCD display information; LCD visual size is 64mm (long) 49mm (wide); Figure 5-1; Table 4-1 for illustration; corresponding display contents of different types of energy meters can be selected as needed.



图 4-1 LCD 显示界面参考图







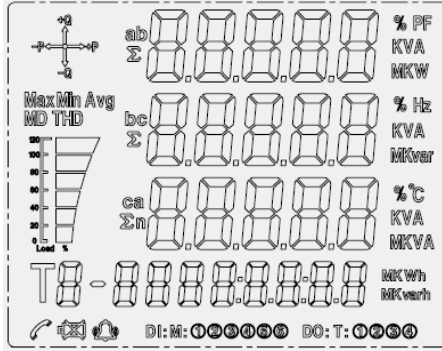

Figure 4-1 LCD display interface reference figure

5.2 液晶显示提示符号含义说明 Description of the LCD display

序号 No.	LCD 图形 LCD figure	说明 Explain
1		分别代表四个象限 Each represents four quadrants
2		负载百分比 = 当前功率/最大功率 × 100% Load percentage = current power / maximum power × 100%
3	THD	表示谐波含量 Indicating harmonic content
4		表示通讯状态 Indicating communication status
5		表示电池状态 Indicates the battery status
6		表示故障状态 Indicates the fault state
7	DI: ①②③④⑤⑥	开关量输入序号 Serial number of switching quantity input
8	DO: ①②③④	开关量输出序号 Serial number of switching quantity output
9	T: ①②③④	费率序号 Rate serial number

六、操作说明 Operating instructions









6.1 显示模式按键功能 Display mode key function

- 按“”键多次，依次上翻切换电压、电流、分相功率、功率因数、相角、合相功率、频率、通讯参数界面。
Press  key many times, and turn up the interface of voltage, current, phase power, power factor, phase Angle, phase power, frequency and communication parameters.
- 按“”键多次，依次下翻切换通讯参数、频率、合相功率、相角、功率因数、分相功率、电流、电压界面。
Press  key many times and turn down the communication parameters, frequency, phase power, phase Angle, power factor, phase power, current and voltage interface.
- 按“”或“”键，可以循环切换费率状态、时间日期、开关量状态指示、费率电能和有无功组合电能显示。
- Press "" or "" keys to cycle the rate status, time date, switch status indication, rate power, and reactive power combination display.

6.2 编程模式按键功能 Programming mode key function

长按“”键 5 秒进入编程模式，输入编程密码 3366 进入设置界面。

Often press the "" key for 5 seconds to enter the programming mode, enter the programming password 3366 to enter the setting interface.

- : 编程功能切换键，主菜单时退出编程；设置菜单中，移位功能，相应位闪烁(向右键)。
: Programming function switch key, exit programming in the main menu, shift function, corresponding bit flashing (right button).
- : 主菜单中，确认功能进入下一级菜单；设置菜单中，确认保存数据 (向左键)。
: In the main menu, enter the confirmation function on to the next menu, save the data (left).
- : 主菜单中，选择菜单相邻的上一个项目；设置菜单中，键入数值时作为递增的功能 (向上键)。
: In the main menu, select the previous item adjacent to the menu; in the settings menu, type a value as an increment function (up key).
- : 主菜单中，选择菜单相邻的下一个项目；设置菜单中，键入数值时作为递减的功能 (向下键)。
: In the main menu, select the next item of the menu; type the setting menu as a decreasing function (key down).

进入编程界面 60S 无操作，自动退出编程模式。

Enter the programming interface 60S no operation, automatically exit the programming mode.

编程举例 Programming examples:

- ◇ 地址修改 (Madd): 将地址改为 10 Address modification (Madd): Change the address to 10

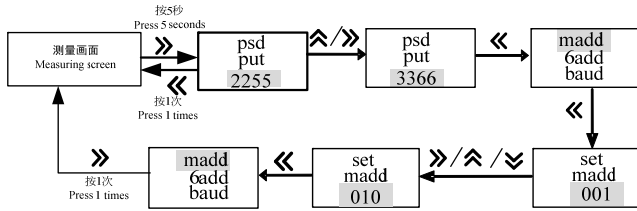

◇ 波特率 (baud) : 将波特率改为 9600 Baud rate (baud) : Change the baud rate to 9600

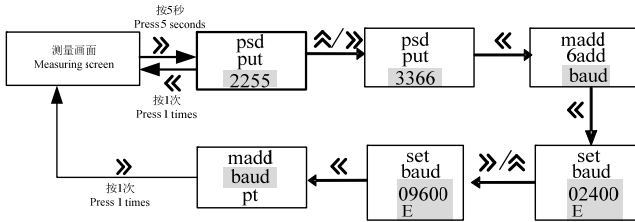

◇ 电流变比 (CT) : 将 CT 改为 100 Current to current ratio (CT): Change CT to 100

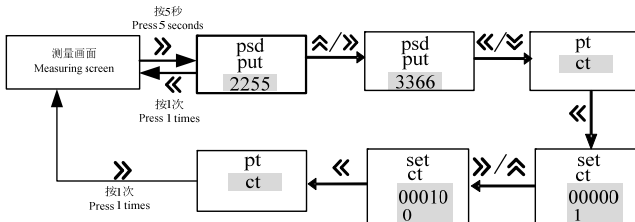

七、仪表的安装与接线 Meter installation and wiring

7.1 仪表安装尺寸图 Meter mounting dimensions

产品安装图 (单位: mm, 公差: ± 0.5) Product installation drawing (unit: mm, tolerance: ± 0.5):

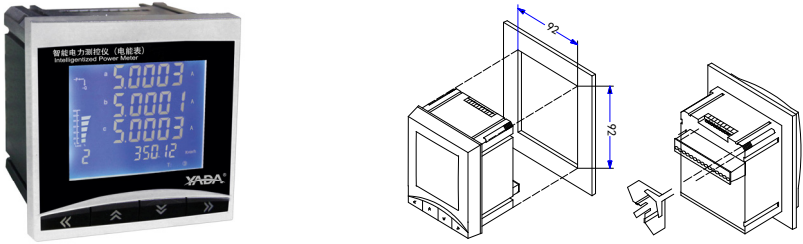

主机外形尺寸 (单位: mm, 公差: ± 0.5) Dimension (unit: mm, tolerance: ± 0.5):

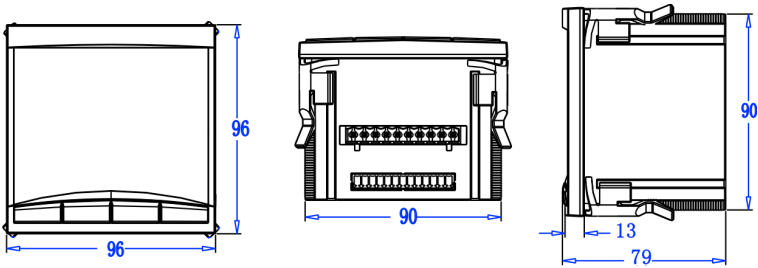

7.2 接线图 Wiring diagram

三相四线经 CT 接入式接法

Three phase four-wire connection CT

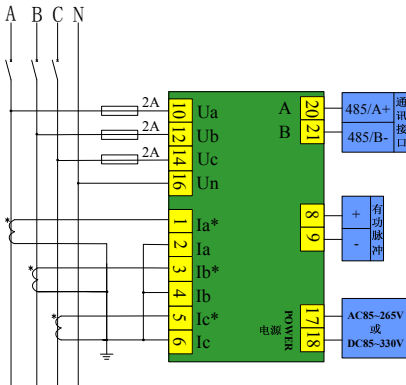

三相四线经 PT、CT 接入式接法

Three-phase four-wire connection CT and PT

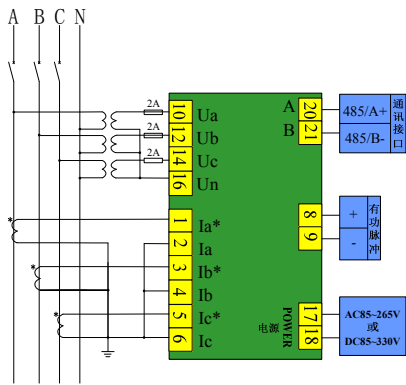

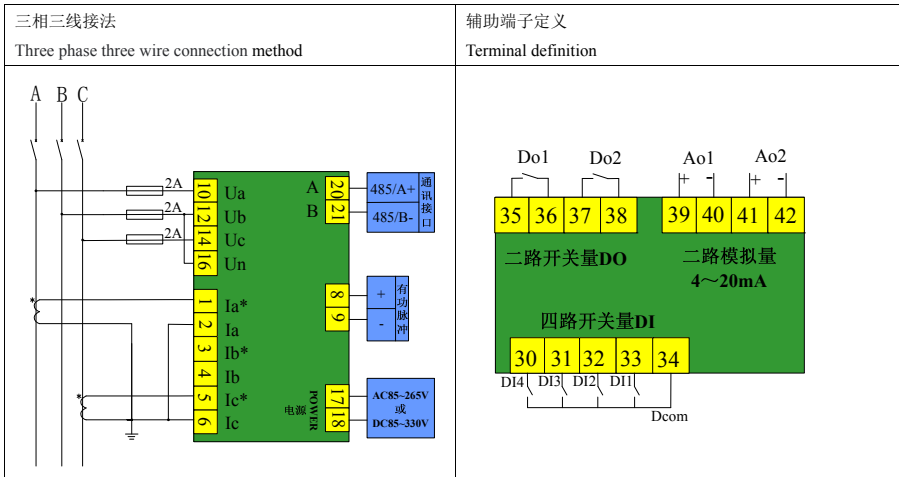

通讯接口	Communication interface
有功脉冲	Active pulse
AC85~265V 或 DC85~330V	AC85~265V or DC85~330V
二路开关量 DO	Two way switch quantity DO
二路模拟量 4~20mA	Two channel analog 4~20mA
四路开关量 DI	Four way switch DI

7.3 有功 (校验)脉冲输出端口示意图 Diagram of active power (parity) pulse output port

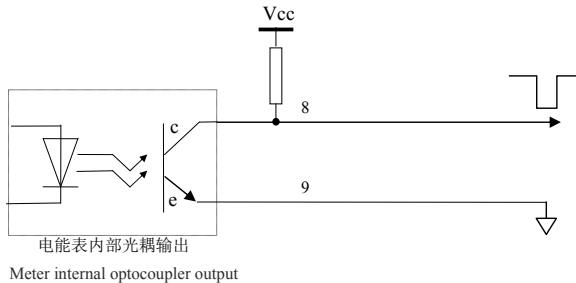

注： Vcc 可选择 5V、12V 或 24V，电阻可选择 $V_{cc}/5mA$ (kΩ)。

Note: Vcc can choose 5V, 12V or 24V, resistance can $V_{cc} / 5mA$ (kΩ).

7.4 开关量接线 Switching quantity wiring

四路无源节点输入，适用于监测断路器位置信号，刀闸位置信号等状态信息，通常采用的接线方式如下：

Four-way passive node input is suitable for monitoring the circuit breaker position signal, switch position signal and other status information. The usual connection mode is as follows:

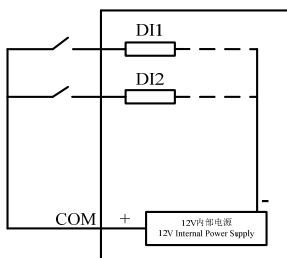

注意：由于内部已提供检测电源，外部节点不允许再接入任何等级的电压，否则会造成开关量输入通道烧毁。

Note: Since the internal detection power has been provided, the external node is not allowed to access any level of voltage, otherwise the switching input channel will burn out.

八、故障对策和异常处理 Fault countermeasures and exception handling

电能表可能出现的故障和现象归纳如表 8-1 所示，用户在寻求技术支持之前，可先按该表提示进行自查，并详细记录故障现象，需要服务时，请与公司技术服务部或销售市场部联系。

The possible faults and phenomena of electricity meters are summarized in Table 8-1. Before seeking technical support, users can conduct self-examination according to the table prompts, and record the fault phenomenon in detail. When service is needed, please contact the technical service department or the sales Marketing Department of the company.

表 8-1 操作异常及对策 Table 8-1 Abnormal operation and countermeasures

异常现象 Possible problems	可能原因 Possible cause	可能解决办法 Possible solution
不工作 Not work	工作电源未连接 Working power supply is not connected	检查辅助电源端子连接和线路连接情况。 Check the power supply terminal connection and line connection.
	工作电源范围不对 working power supply range is wrong	确认连接电源电压大小，可用万用表测量并与面板标识比较，是否在范围内。 Check whether the connected power supply voltage is within the range measured by a multimeter and compared with the panel label.
通讯连接不上 Communication can't be connected	不工作 Not work	对策同上描述。 The countermeasures are described above.
	通讯未连接 The communication is not connected	按说明连接通讯。 Follow the instructions to connect communication.
	通讯地址错误 Communication address error	通讯连接章节说明，更改通讯地址。 Description of the communication connection section, change the mailing address. 组网通讯时地址更改出现重复，重新检查设置。 If the address change is repeated during network communication, check the Settings again.
	通讯参数设置不对 Communication parameters are incorrect	查看说明书出厂设置，重新设置上位机通讯参数或按照说明更改电表通讯参数。 Check the factory setting of the manual, reset the communication parameters or change the communication parameters according to the instructions.
按键无反应 The button is not responsive	按键速度太快 The keys are too fast	正常频率按键。 Normal frequency button.
	按键功能异常 The button function is abnormal	若影响使用，可联系服务。 If it affects use, you can contact the service.
按键设置不了 The keys can't be set	操作不对 The operation is wrong	具体操作请参考说明书按键操作说明部分。 For specific operations, please refer to the manual key operation instructions section.

测量数值不正确或者与期望不符 Measurement values are incorrect or not consistent with expectations	电压测量不正确 Voltage measurement is wrong	<p>检测中性点连接是否可靠。 Test whether the neutral point connection is reliable.</p> <p>检测测量电压是否与额定参数匹配。 Check the whether the measured voltage matches the rated parameters.</p> <p>检查电压相线连接是否可靠。 Check whether the voltage phase line connection is reliable.</p> <p>检查 PT 连接是否正确。 Check that the PT connection is correct.</p>
	电流测量不正确 Current measurement is wrong	<p>检测测量电流是否与额定参数匹配。 Check the whether the measured current matches the rated parameters.</p> <p>检查外置 CT 连接是否正确。 Check whether the CT ratio parameter is set correctly</p>
	功率测量不正确 Power measurement is wrong	<p>检查电压电流对应相序是否正确。 Check whether the phase sequence of voltage and current is correct</p> <p>检查电流同名端是否错误。 Check whether the current direction is correct</p>
	电能计量不正确 Energy measurement is wrong	<p>检查电压电流对应相序是否正确。 Check whether the corresponding phase sequence of the voltage and current is correct.</p> <p>确认测量线路实际使用是否在设备精度范围内。 Confirm whether the actual use of the measurement line is within the accuracy range of the equipment.</p>

九、运输与存贮 Transportation and storage

保存地点环境温度应为-40~+70℃，相对湿度不超过 95%RH，且在空气中不含有足以引起腐蚀的有害物质，并且应在原包的条件放置，叠放高度不超过 5 层。电表在包装拆封后不宜储存。

The ambient temperature of the storage place should be -40~+70℃, the relative humidity should not exceed 95%RH, and the air does not contain harmful substances sufficient to cause corrosion. And should be placed under the condition of the original package, stacked height of no more than 5 layers. The meter should not be stored after unpacking

产品在运输和拆封时不应受剧烈冲击，并根据 GB/15464-1995《仪器仪表包装通用技术条件》的规定运输和存储。

The product shall not be subjected to violent shocks during transportation and unpacking, and shall be transported and stored in accordance with the provisions of GB/15464-1995 "General Technical Conditions for Instrument Packaging".

搬运、取用、安装过程中受到剧烈撞击或高空坠落造成外壳有明显损毁痕迹时，请不要对该表加电，并尽快联络供应商。

If there is obvious damage caused by severe impact or high altitude fall during handling, use or installation, please do not power on the meter and contact the supplier as soon as possible..

十、保证期限 Period of guarantee

电表自出厂日起 18 个月内，如用户发现不符合上述特性及技术要求，或由有关电力计量部门证明，又完全按照本说明书中所规定的要求操作的情况下，我公司负责免费修理。

Within 18 months from the factory date, if the user finds that the meter does not meet the above characteristics and technical requirements, or is proved by the relevant power metering department, and operates in accordance with the requirements stipulated in this manual, our company will be responsible for free repair.

附录 A

Appendix A

显示项目列表 Display a list of items

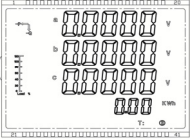
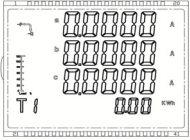
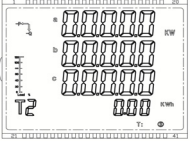
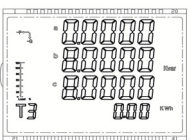
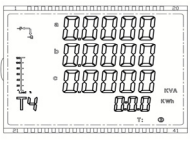
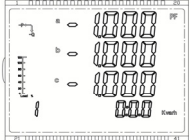
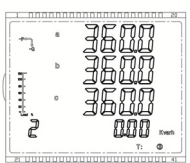
序号 No.	显示项目 Displays the project	数据显示格式 Data display format
1		第一行: A 相电压 First row: A phase voltage 第二行: B 相电压 Second row: B phase voltage 第三行: C 相电压 Third row: C phase voltage 第四行: 组合有功总电能 The fourth row: combine the total active energy
2		第一行: A 相电流 First row: A phase current 第二行: B 相电流 Second row: B phase current 第三行: C 相电流 Third row: C phase current 第四行: 组合有功尖电能 The fourth row: combine active sharp energy
3		第一行: A 相有功功率 First row: A phase active power 第二行: B 相有功功率 Second row: B phase active power 第三行: C 相有功功率 Third row: C phase active power 第四行: 组合有功峰电能 The fourth row: combine the active peak energy
4		第一行: A 相无功功率 First row: A phase reactive power 第二行: B 相无功功率 Second row: B phase reactive power 第三行: C 相无功功率 Third row: C phase reactive power 第四行: 组合有功平电能 The fourth row: combine the active flat energy
5		第一行: A 相视在功率 First row: A phase apparent power 第二行: B 相视在功率 Second row: B phase apparent power 第三行: C 相视在功率 Third row: C phase apparent power 第四行: 组合有功谷电能 The fourth row: combine the active valley energy
6		第一行: A 相功率因数 First row: A phase power factor 第二行: B 相功率因数 Second row: B phase power factor 第三行: C 相功率因数 Third row: C phase power factor 第四行: 组合无功 1 电能 The fourth row: combine the reactive 1 energy
7		第一行: A 相电压与电流夹角 First row: Angle between A phase voltage and current 第二行: B 相电压与电流夹角 Second row: Angle between B phase voltage and current 第三行: C 相电压与电流夹角 Third row: Angle between C phase voltage and current 第四行: 组合无功 2 电能 The fourth row: combine the reactive 2 energy

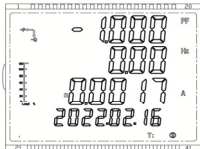
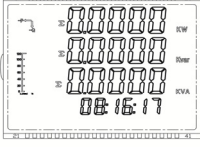
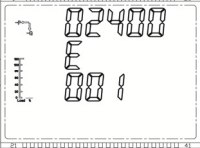
8		<p>第一行：合相功率因数 First row: Combination power factor</p> <p>第二行：频率 Second row: Frequency</p> <p>第三行：零线电流 Third row: Zero-line current</p> <p>第四行：日期 The fourth row: Date</p>
9		<p>第一行：合相有功功率 First row: Combined active power</p> <p>第二行：合相无功功率 Second row: Combined reactive power</p> <p>第三行：合相视在功率 Third row: Combined apparent power</p> <p>第四行：时间 The fourth row: time</p>
10		<p>第一行：通讯速率 First row: Communication rate</p> <p>第二行：通讯校验位 Second row: Communication check bit</p> <p>第三行：Modbus 地址 Third row: Modbus address</p>

注：以上图片仅供参考，产品以实物为准。

Note: The above pictures are for reference only, the product is subject to the physical object.



广东省河源市高埔岗雅达工业园

Guangdong Yada Electronics Co.,Ltd.

地址：广东省河源市高埔岗雅达工业园

Address:Yada industry park, Gaopugang, Heyuan city, Guangdong Province.

国内业务 Domestic market: 86-762-3493871 3493872 3493873

国外业务 International market: 86-762-3496222

技术支持 Technical support: 86-762-3493926 3493989 (400-830-0868)

传 真 Fax: 86-762-3493912 3493830

邮 编: 517000

http: //www.yada.com.cn

E-mailZip code: market@yada.com.cn

版权所有，保留一切权利。内容如有改动，恕不另行通知。

Copyright, all rights reserved. Specification subject to change without prior notice.