



NO: 13040503.0196.01

YDM500D 型电子式直流电能表
YDM500D Electronic DC Energy Meter
说明书
Instruction



广东雅达电子股份有限公司
Guangdong Yada Electronics Co.,Ltd



危险和警告 Danger and warning

在进行安装、操作或者维护此设备之前，请仔细阅读本手册，拿到它并逐步熟悉设备。本文件不是一本适用于未受训者的操作手册，在其正常使用范围之外所引起的问题，本公司概不负责。

Before installing, operating or maintaining the equipment, please read this manual carefully, get it and gradually get familiar with the equipment. This document is not an operating manual for non-trainees, and our company are not responsible for any problems arising out of its normal use.



触电、燃烧或者爆炸的危险 Risk of electric shock, fire or explosion

- 本设备部分存在电力危险，请严格按照规范进行作业。
- There is a power hazard in some parts of this equipment. Please operate in strict accordance with the specifications.
- 在维护和检修之前，设备必须断电并接地。
- Before maintenance and overhaul, the equipment must be powered off and grounded.
- 在设备通电前，应将所有的机械部件，门和盖子等恢复原位。
- All mechanical parts, doors and covers should be returned to their original position before the equipment is energized.
- 设备维护和安装工作只能由有资质的人员执行。
- Equipment maintenance and installation work can only be performed by qualified personnel.

若不注意这些预防措施可能会引起严重伤害。

If you do not pay attention to these precautions, it may cause serious injury.

目录 Contents

第一章 产品介绍 Chapter I Introduction	1
1.1 概述 General	1
1.2 相关技术标准 The technical standards	1
1.3 型号说明 Model description	1
1.4 功能介绍 Function introduction	2
第二章 安装 Chapter II Installation	3
2.1 安装预防、准备 Installation, prevention and preparation	3
2.2 安装信息 Installation information	3
2.2.1 安装注意事项 Notes for installation	3
2.2.2 安装尺寸：导轨安装 Installation size: guide rail installation	4
2.3 端子定义 Terminal definition	4
2.4 接线图纸 Wiring drawings	5
2.4.1 电源 Power supply	5
2.4.2 电压电流 Voltage and current	5
2.4.3 通讯 Communication	6
第三章 使用与操作 Chapter III use and operation	7
3.1 键盘定义 Keys definition	7
3.2 显示说明 Display	7
3.2.1 显示功能说明 Display definition	7
3.2.2 数据画面说明 Description of data screen	7
3.2.3 参数设置画面 Parameter setting	10
第四章 技术指标 Chapter IV Technical indicators	13
4.1 规格 Specifications	13
4.1.1 脉冲常数与功率对照表 The table of pulse constant and power	13
4.2 技术参数 Technical parameter	13
4.2.1 基本误差 Basic error	13
4.2.2 潜动 Shunning	14
4.2.3 功率消耗 Power consumption	14
4.2.4 工作环境条件 Working conditions	14
4.2.5 通讯参数 Communication parameters	14
4.2.6 电磁兼容 Electromagnetic compatibility	15
第五章 维护和故障排除 Chapter V Maintenance and Troubleshooting	16
5.1 故障排除 Troubleshooting	16

第六章 质量保证 Chapter VI Quality Assurance	17
6.1 质量保证 Quality Assurance	17
6.2 质量限制 Quality limitation	17

第一章 产品介绍 Chapter I Introduction

1.1 概述 General

YDM500D型电子式直流电能表是我公司生产的新一代直流计量产品，主要针对双枪或多枪直流充电桩应用，可同时实现两路直流接入和计量，具有2路独立RS485通讯接口，可分别数据上传。

YDM500D Electronic DC energy meter is a new generation of DC metering products produced by our company, mainly for dual-gun or multi-gun DC charging pile applications, can achieve two DC access and metering at the same time, with two independent RS485 communication interfaces, can upload data respectively

仪表由测量单元、数据处理单元、通讯单元、显示单元等组成，具有电能计量、数据处理、实时监测、LCD显示功能。电能表具有高倍过载、高精度、低功耗、停电数据自动保存、长寿命等特点。

It consists of measurement unit, data processing unit, communication unit, display unit, etc., with power measurement, data processing, real-time monitoring, LCD display function. The energy meter has the characteristics of high power overload, high accuracy, low power consumption, automatic saving of power failure data and long life.

1.2 相关技术标准 The technical standards

GBT 33708-2017 《静止式直流电能表》

GBT 33708-2017 "Static DC Energy Meter"

GB/T29318-2012 《电动汽车非车载充电电能计量》

GB/T29318-2012 "Electric Vehicle non-on-board charging energy Measurement"

Q/GDW 1825-2013 《直流电能表技术规范》

Q/GDW 1825-2013 DC Meter Technical Specification

Q/GDW 364-2009 《单相智能电能表技术规范》

Q/GDW 364-2009 "Single Phase Smart Energy meter Technical Specification"

JJG 842-2017 《电子式直流电能表》

JJG 842-2017 "Electronic DC Energy Meter"

JJG 1148-2018 《电动汽车交流充电桩检定规程》

JJG 1148-2018 "Electric Vehicle AC Charging Pile Verification Regulations"

1.3 型号说明 Model description

型号 Model	规格 Specifications	功能 Function
YDM500D	单路 Single	单路直流测量、单路电能脉冲输出、一路秒脉冲输出、1路独立RS485接口。 Single DC measurement, one electric power pulse output, one second pulse output, one independent RS485 ports.

	双路 Double	双路直流测量、两路电能脉冲输出、一路秒脉冲输出、2路独立 RS485 接口。 Double DC measurement, two electric power pulse output, one second pulse output,two independent RS485 ports.
--	--------------	--

1.4 功能介绍 Function introduction

- ◇ 正反向电能计量，组合=正向+反向；
- ◇ Positive and reverse electric energy metering, combination = forward + reverse;
- ◇ 电压、电流、功率测量；
- ◇ Voltage, current, and power measurement;
- ◇ 1路红外通讯接口和2路独立 RS-485 通讯接口，采用 DL/T645-2007 通讯协议和 Modbus (RTU 格式) 协议，RS485 的通讯速率可在 1200bps、2400bps、4800bps、9600bps、19200bps 设置，调制红外的通讯速率固定为 1200bps。
- ◇ 1 infrared communication interface and 2 independent RS-485 communication interface,using DL/T645-2007 communication protocol and Modbus (RTU format) protocol, the communication rate of RS485 can be set at 1200bps、2400bps、4800bps、9600bps and 19200bps setting, and the communication rate of modulation infrared is fixed to 1200bps.

第二章 安装 Chapter II Installation

2.1 安装预防、准备 Installation, prevention and preparation

请在开始操作前阅读 Read it before starting the operations

本章包含重要的安全预防信息，在安装、服务或维护电气设备前必须遵守这些指导。仔细阅读并遵循下列安全预防指导。

This chapter contains important safety precautions information that must be followed prior to installation, service, or maintenance of electrical equipment. Read carefully and follow the following safety precautions instructions.



电击，烧毁或爆炸的危险，所以只有合格的操作人员才能安装本设备。此工作应在阅读了该全部指导后开展。在进行安装，检验，测试或维护前，应断开所有的电源连接。请依照说明书中的接线说明接线，接完后要认真核对接线是否正确无误。意识到潜在的危险，工作人员需佩戴保护设备，仔细检查工作接线和安装是否正确。安装或者拆除仪表时，请确认电源、待测信号源及相关电源是否完全断开。



Electric shock, the danger of burning or explosion, so only qualified operators can install this equipment. This work should be carried out after reading all the guidance. All power connections shall be disconnected before installation, inspection, testing or maintenance. Please follow the wiring instructions in the instructions. After the connection, carefully check whether the wiring is correct. Awareness of the potential danger, staff should wear protective equipment and carefully check the correct wiring and installation. When installing or removing the instrument, please confirm whether the power supply, the signal source to be tested and the related power supply are completely disconnected.

2.2 安装信息 Installation information

2.2.1 安装注意事项 Notes for installation

- ◇ 仪表应安装在干燥、清洁、远离热源和强电磁场的地方；
- ◇ The meter shall be installed where dry, clean and away from heat and strong electromagnetic fields;
- ◇ 仪表位置通常安装在开关柜中，可使装置不受油、污物、灰尘、腐蚀性气体或其他有害物质的侵袭；
- ◇ The meter position is usually installed in the switch cabinet, which can protect the device from oil, dirt, dust, corrosive gas or other harmful substances;
- ◇ 安装时要注意检修方便，有足够的空间放置有关的线、端子排、短接板和其他必要的设备；
- ◇ When installing, pay attention to convenient maintenance, and there is enough space to place the relevant lines, terminal row, short connection board and other necessary equipment;
- ◇ 直流分流器mv信号输出连接线建议采用1.5mm²屏蔽双绞线，分流器与仪表接线距离不宜过长，建议线长在1米以内；电压输入线、电源线用1.5mm²多股阻燃铜线；RS-485通信用1.0mm²屏蔽双绞线；
- ◇ It is recommended to use 1.5mm² shielding twisted pair cable for DC shunt, the connection distance between shunt and instrument

should not be too long, the wire length is recommended within 1 m; 1.5mm² multiple flame retardant copper wire for voltage input line and power line; 1.0mm² shielding twisted pair for RS-485 communication;

- ◇ 仪表电压输入回路必须接入合适的保险丝。
- ◇ The instrument voltage input circuit must be connected to a suitable fuse.

2.2.2 安装尺寸：导轨安装 Installation size: guide rail installation

单位：mm unit: mm
公差：±0.5 tolerance: ±0.5

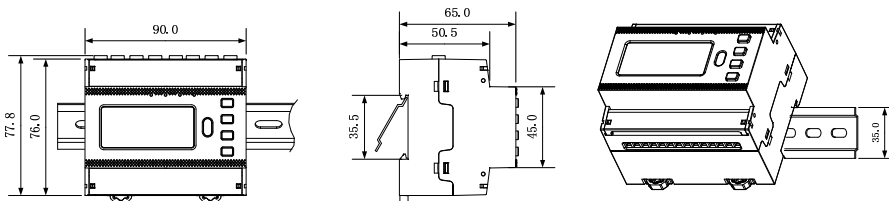

外形尺寸：长*宽*高(90.0)mm*(77.8)mm*(65.0)mm

External dimensions: (L) * (W) * (H) (90.0) mm * (77.8) mm * (65.0) mm

重量：约 0.261kg

Weight: about 0.261kg

2.3 端子定义 Terminal definition

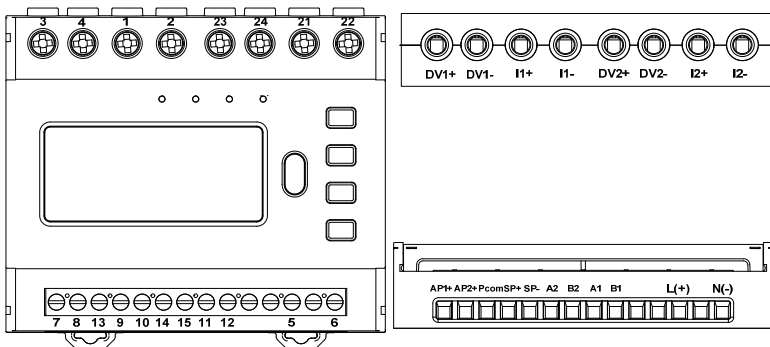

注：单路规格时 8、14、15、21、22、23、24 端子无效。

Note: 8, 14, 15, 21, 22, 23, 24 terminals are not valid for single circuit specifications.

端子号 Terminal number	端子定义 Terminal definition	注释 Note	端子号 Terminal number	端子定义 Terminal definition	注释 Note
3	DV1+	第一路电压输入正极 The first loop of voltage input positive electrode	7	AP1+	第一路脉冲输出正极 The first pulse output positive

4	DV1-	第一路电压输入负极 The first loop of voltage input reverse electrode	8	AP2+	第二路脉冲输出正极 The second pulse output positive
1	I1+	第一路电流输入正极 The first loop of current input positive electrode	13	Pcom	脉冲输出公共端 Pulse output common port
2	I1-	第一路电流输入负极 The first loop of current input reverse electrode	9	SP+	秒脉冲输出正极 Second pulse output positive
23	DV2+	第二路电压输入正极 The second loop of voltage input positive electrode	10	SP-	秒脉冲输出负极 Second pulse output reverse
24	DV2-	第二路电压输入负极 The second loop of voltage input reverse electrode			
21	I2+	第二路电流输入正极 The second loop of current input positive electrode	11	A1	485-1 通讯端口 485-1 Communication port
22	I2-	第二路电流输入负极 The second loop of current input reverse electrode	12	B1	
5	L(+)	工作电源 Power supply	14	A2	485-2 通讯端口 485-2 Communication port
6	N(-)		15	B2	

2.4 接线图纸 Wiring drawings

2.4.1 电源 Power supply

工作电源输入兼容交流及直流输入。

The working power input is compatible with AC and DC inputs.

①AC220V(±20%)输入时，相线接L端，中性线接N端，DC220V(±20%)输入时，正极接L端，负极接N端；

①When inputting AC220V (±20%), connect the phase line to the L terminal and the neutral line to the N terminal. When inputting DC220V (±20%), connect the positive terminal to the L terminal and the negative terminal to the N terminal;

②DC10V~30V 输入时，正极接+端，负极接-端，具体参照铭牌标注信息。

②When DC10V~30V input, the positive terminal is connected to the + end, and the negative terminal is connected to the - end, specifically refer to the nameplate marking information.

2.4.2 电压电流 Voltage and current

第一回路 The 1st loop

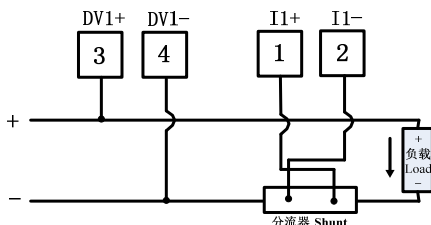

第二回路 The 2nd loop

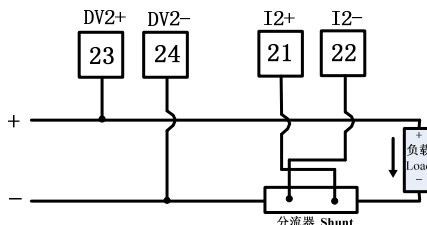

分流器接负端 The shunt is connected to the negative

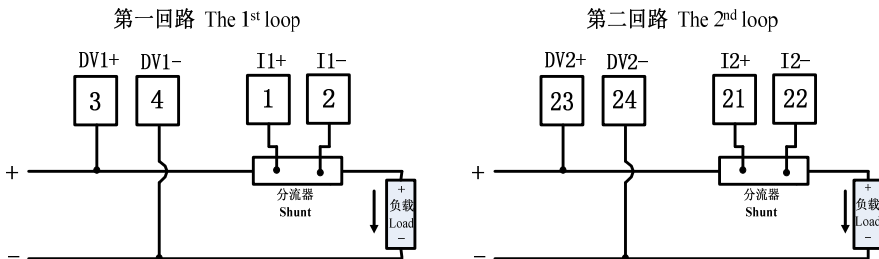

分流器接正端 The shunt is connected to the positive

注：仪表内部电压、电流输入电气隔离，两回路之间电气隔离。

Note: The internal voltage and current meter are electrically isolated, and the two circuits are electrically isolated.

2.4.3 通讯 Communication

2路独立RS-485通信口，端子分别标记为A1、B1、A2、B2。

Two independent RS-485 communication ports ,Terminals are marked with A1, B1, A2, B2

每个 RS-485 通信接口允许一条总线上最多接 32 台仪表，通信电缆可以采用普通的屏蔽双绞线，总长度不宜超过 1200 米，各个设备的 RS-485 口正负极性必须连接正确。如果屏蔽双绞线较长，建议在其末端接一个约 120Ω 的电阻以提高通信的可靠性。

Each RS-485 communication interface allows up to 32 instruments to be connected to a bus. Communication cable can use ordinary shielded twisted pair, the total length should not exceed 1200m, the positive and negative polarity of RS-485 port of each equipment must be connected correctly. If the shielding twisted pair is long, it is recommended to have a resistance of about 120 Ω at its end to improve the reliability of the communication.

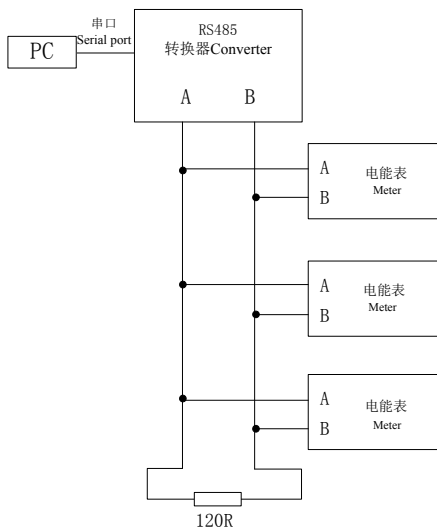



第三章 使用与操作 Chapter III use and operation

3.1 键盘定义 Keys definition

键盘有 4 个按键组成, 分别是  ,  ,  , 

There are four keys, they are  ,  ,  , 

 : 回到上一级画面, 设置数据时: 左移修改闪动位。

 : Go back to the next level, when setting the data: Move left to modify the flashing bit

 : 画面向上切换, 设置数据时: 数据加一。

 : The screen switches up, when setting the data: the data plus one

 : 画面向下切换, 设置数据时: 数据减一。

 : The screen switches down. When setting the data: the data minus one.

 : 进入下一级画面, 设置数据时: 1. 长按 3S 进入设置界面。2. 修改参数后确认返回。

 : Go to the next screen, When setting the data: 1. Long press 3S to enter the setting interface. 2. Confirm the return after modifying parameters.

3.2 显示说明 Display

3.2.1 显示功能说明 Display definition







- ◇ 采用液晶显示, 显示方式分为自动循环显示和按键显示两种, 显示项目不可设, 具体显示项见 3.2.2 说明;
- ◇ LCD display, The display mode is divided into automatic cycle display and button display. The display items cannot be set. For the specific display items, see 3.2.2;
- ◇ 显示具有背光功能, 背光为白色, 可通过按键点亮, 无操作 2 个自动轮显周期后自动关闭;
- ◇ The display has backlighting and the backlight is white, It can be turned on by pressing the key and shut off automatically after no operation of 2 automatic wheel display cycles;
- ◇ 可显示累计电能、电压、电流、功率等信息;
- ◇ It can display the accumulative energy, voltage, current, power, time and other information;
- ◇ 电能显示为 8 位数, 显示 2 位或 3 位小数可设, 计量单位 kWh。
- ◇ The energy is displayed as 8 digits, with 2 or 3 decimal places, and the unit of measurement is kWh.

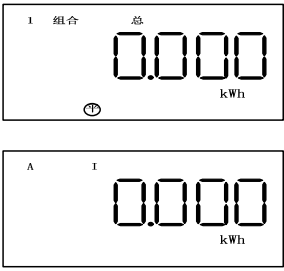
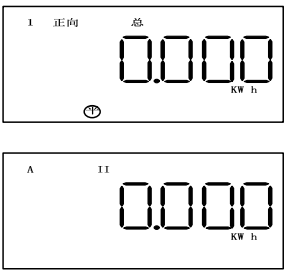
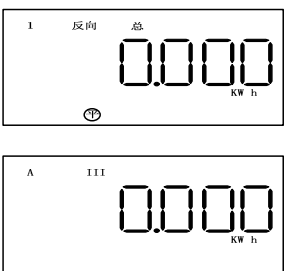
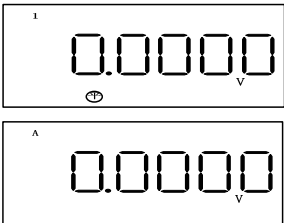
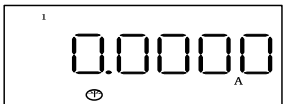

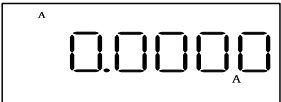
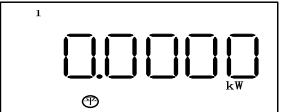
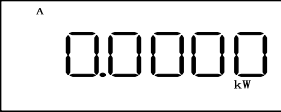
3.2.2 数据画面说明 Description of data screen

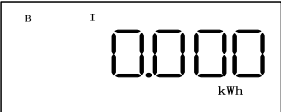
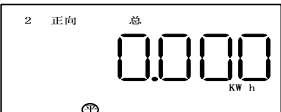
通过 ▲ 键或 ▼ 键可切换数据画面如下：

Through ▲ or ▼ toggles the data screen as follows:

序号 NO.	显示界面 Display interface	说明 Explain
1		第 1 回路组合总电量 The first loop of combination total power
2		第 1 回路正向总电量 The first loop of positive total power
3		第 1 回路反向总电量 The first loop of reverse total power
4		第 1 回路电压 The first loop of voltage
5		第 1 回路电流 The first loop of current

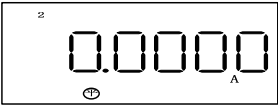
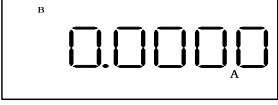
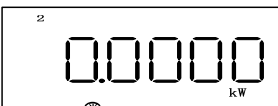
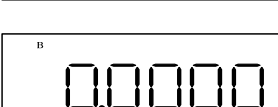
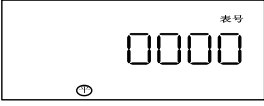
		
6	 	第 1 回路功率 The first loop of power
7	 	第 2 回路组合总电量 The second loop of combination total power
8	 	第 2 回路正向总电量 The second loop of positive total power
9	 	第 2 回路反向总电量 The second loop of reverse total power
10		第 2 回路电压 The second loop of voltage

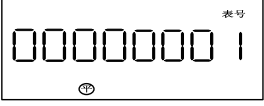
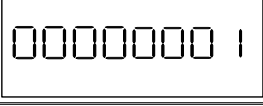

		
11	 	第 2 回路电流 The second loop of current
12	 	第 2 回路功率 The second loop of power
13	 	表号高 4 位 The meter ID is 4 digits higher
14	 	表号低 8 位 The meter ID is 8 digits lower

3.2.3 参数设置画面 Parameter setting



长按  键 3S 进入密码界面，修改密码值为“3366”进入设置画面；

Long press  Key 3s enters the password interface and modifies the password is 3366;

通过  键或  键切换所需设置菜单；

Through  or  to switch the required settings menu;

通过  键进入设置菜单修改界面，修改数值后按  键返回设置菜单，再按  键退出设置画面。

Through  to the settings menu to modify the interface, after modifying the number, press  back to the settings menu,

and then press  exit setting screen.

设置菜单说明如下图：

The setup menu description is as follows:

645Adr	H-000000
	DL/T645-2007 地址高 6 位 DL / T645-2007 address is 6 high bits
	L-000000
DL/T645-2007 地址设置 DL/T645-2007 Address setting	DL/T645-2007 地址低 6 位 DL/T645-2007 address is low 6 bits

n.Adr	001
Modbus-RTU 地址设置 DL/T645-2007 Address setting	Modbus-RTU 地址 Modbus-RTU Address

bAUD 1	09600n	09600o	09600E
	设置为 9600 None、9600 Odd 或 9600 Even Set to 9600 None、9600 Odd or 9600 Even		
	19200n	19200o	19200E
	设置为 19200 None、19200 Odd 或 19200 Even Set to 19200 None、19200 Odd or 19200 Even		
	01200n	01200o	01200E
设置为 1200 None、1200 Odd 或 1200 Even Set to 1200 None、1200 Odd or 1200 Even			

bAUD1	02400n	02400o	02400E
	设置为 2400 None、2400 Odd 或 2400 Even Set to 2400 None、2400 Odd or 2400 Even		
bAUD2	04800n	04800o	04800E
	设置为 4800 None、4800 Odd 或 4800 Even Set to 4800 None、4800 Odd or 4800 Even		
1、2 回路通讯波特率及校验位设置 Communication baud rate and check bit setting of the 1 st and 2 nd loop		设置为 4800 None、4800 Odd 或 4800 Even Set to 4800 None、4800 Odd or 4800 Even	

̄A4CUr1	0300
第 1 回路最大电流设置 The 1 st loop of maximum current setting	第 1 回路最大电流 The 1 st loop of maximum current
̄A4CUr2	0300
第 2 回路最大电流设置 The 2 nd loop of maximum current setting	第 2 回路最大电流 The 2 nd loop of maximum current
dISP	0 1
中英文显示设置 Choose between Chinese and English	0: 中文 1: 英文 0: Chinese 1: English

第四章 技术指标 Chapter IV Technical indicators

4.1 规格 Specifications

额定电压(Un) Rated voltage (Un)	DC100V、DC300V、DC500V、DC700V、DC750V、DC1000V
额定电流(In) Rated current (In)	50A、100A、150A、200A、250A、300A、350、400A、450A、500A、600A、700A、800A 等可设置（最大测量值 4800.0000A），采用外置 75mV 分流器输入 50A, 100A, 150A, 200A, 250A, 300A, 350, 400A, 450A, 500A, 600A, 700A, 800A and so on can be set (Maximum measured value 4800.0000A), using external 75mV shunt input.
脉冲常数 Pulse constant	以实际铭牌标注为准，可设置 It can be set according to the actual nameplate, may be set.
辅助电源 Power supply	输入电压范围：①AC220V/DC220V(±20%) ②DC10V~30V Input voltage range: ①AC220V/DC220V(±20%) ②DC10V~30V

4.1.1 脉冲常数与功率对照表 The table of pulse constant and power

序号 NO.	脉冲常数(imp/kWh) Pulse constant (imp/kWh)	功率范围 (W) Power range (W)
1	25600	900 > Pmax
2	12800	1800 > Pmax ≥ 900
3	6400	3600 > Pmax ≥ 1800
4	3200	7200 > Pmax ≥ 3600
5	1600	14400 > Pmax ≥ 7200
6	800	28800 > Pmax ≥ 14400
7	400	57600 > Pmax ≥ 28800
8	200	115200 > Pmax ≥ 57600
9	100	230400 > Pmax ≥ 115200
10	50	460800 > Pmax ≥ 230400
11	25	921600 > Pmax ≥ 460800
12	12	1920000 > Pmax ≥ 921600
13	6	3840000 > Pmax ≥ 1920000

4.2 技术参数 Technical parameter

4.2.1 基本误差 Basic error

在额定电压 (Un) 下，电能表的基本误差不应超过下表的误差极限 Under rated voltage (Un), the basic error of the meter should not exceed the error limit of the meter below		
负载电流 (I) 变化范围 Load current (I) changes range	误差限值 Error limit	
	0.5 级 0.5Class	1 级 1Class
0.01In ≤ I < 0.05In Error limit	±1.0%	—
0.02In ≤ I < 0.05In	—	±1.5%
0.05In ≤ I ≤ Imax	±0.5%	±1.0%

在额定电流 (In) 下, 电能表的基本误差不应超过下表误差极限		
Under rated current (In), the basic error of the meter should not exceed the error limit of the meter below		
电压 (U) 变化范围	误差限值 Error limit	
Voltage (U) changes range	0.5 级	1 级
	0.5Class	1Class
$0.1U_n \leq U < 0.4U_n$	$\pm 1.0\%$	$\pm 1.5\%$
$0.4U_n \leq U < 1.3U_n$	$\pm 0.5\%$	$\pm 1.0\%$

4.2.2 潜动 Shunning

在参比条件下电能表电流线路短路, 电压电路分别施加 1.1Un 和 0.8Un, 在 20min 时间内, 电能表不应有脉冲输出或代表脉冲输出的指示灯无闪烁。

In the reference condition, the current circuit of the power meter is short-circuited, and the voltage circuit is applied 1.1Un and 0.8Un respectively. In the 20min time, The meter should not have pulse output or indicator light representing pulse output without flashing.

4.2.3 功率消耗 Power consumption

电压线路	$\leq 1W$
Voltage line	
电流线路	$\leq 0.5W$
Current line	
辅助电源线路	① $\leq 2W$ ② $\leq 4W$
Power supply line	

4.2.4 工作环境条件 Working conditions

工作温度范围	$-25^{\circ}C \sim 60^{\circ}C$
Working temperature range	
极限工作温度范围	$-40^{\circ}C \sim 70^{\circ}C$
The limit working temperature range	
储存运输极限温度	$-40^{\circ}C \sim 70^{\circ}C$
Storage transport limit temperature range	
相对湿度	$< 75\%$ (年平均)
Relative humidity	$< 75\%$ (The annual average)

4.2.5 通讯参数 Communication parameters

4.2.5.1 通讯接口 Communication port

仪表配置有2个RS485通讯接口和1路红外通讯接口。

The meter configuration has two RS485 communication port and an infrared communication port

4.2.5.2 数据读写 Data reading and writing

通过RS485接口, 可完成参数设置和抄读数据。兼容DL/T 645-2007、Modbus-RTU协议, 通讯时自动识别切换, 各协议实现功能分别如下:

Parameter setting and reading data can be completed through the RS485 interface. Compatible with DL/T 645-2007, Modbus-RTU protocol, automatic identification switching during communication, the functions of each protocol are as follows:

DL/T645-2007协议：可读取实时电参量（电压、电流、功率等），当前有功电能及费率电能，上12月结算电能，事件记录数据。费率设置，电表清零功能。具体参照对应协议详述。

DL/T645-2007 protocol:It can read real-time electrical parameters (voltage, current, power,), current active power and rate power,settle energy in last December , event recording data. Rate setting, meter clear function. Refer to the corresponding protocol for details.

Modbus-RTU协议：可读取实时电参量（电压、电流、功率），当前有功电能及费率电能。可设置第一套费率，电表清零功能。具体参照对应协议详述。

Modbus-RTU protocol:It can read real-time electrical parameters (voltage, current, power,), current active power and rate power.It can set the first rate, meter clear function. Refer to the corresponding protocol for details.

4.2.5.3 通讯参数设置 Communication parameter setting

通讯地址、波特率、校验位可通过按键设置和RS485接口设置。

Communication address, baud rate, check bit can be set by pressing key and RS485 interface.

通讯地址：DL/T645-2007协议通讯地址默认为产品编码（12位BCD码），Modbus协议地址默认为01。

Communication address:The DL/T645-2007 protocol communication address defaults to the product code (12-bit BCD code),the Modbus protocol address defaults to 01.

波特率：1200/2400/4800/9600/19200bps可设，校验位（可设）：奇/偶/无。

Baud rate: 1200/2400/4800/9600/19200bps Can be set,Check bit (can be set): odd / even / none.

注：默认出厂为2400bps，偶校验。校验位如另有要求，请以实际产品为准。

Note: The default factory is 2400bps, even parity. If the check digit is required, please refer to the actual product.

4.2.5.4 通讯地址 Communication address

YDM500D具有2个独立DL/T645-2007协议通讯地址和2个modbus-rtu协议的通讯地址，设置地址默认为第1回路的地址，第二回路的地址在第1路地址基础上加1。

YDM500D has two independent DL/T645-2007 protocol communication addresses and two modbus-rtu protocol communication addresses, set the address default to the address of the first loop, the address of the second loop in the first address on the basis of adding 1.

4.2.6 电磁兼容 Electromagnetic compatibility

绝缘强度 Dielectric strength	电压/电源/外壳: 4.0kV/min 通讯/电源: 4.0kV/min Voltage / Power / Sheet: 4.0kV/min Communication / power supply: 4.0kV/min
静电抗扰 Static immunity	接触放电 6kV 空气放电 8kV Contact Discharge 6kV Air Discharge 8kV
电快速脉冲群抗扰性 Electrical fast burst immunity	4kV
浪涌抗扰性 Surge immunity	2kV/4kV

第五章 维护和故障排除 Chapter V Maintenance and Troubleshooting

5.1 故障排除 Troubleshooting

可能问题 Possible problem	可能原因 Possible cause	可能解决方案 Possible solutions
上电后无显示 No display after power-on	电源未能加入到设备上 The power supply is not added to the meter	检查设备 L/+和 N/-端子上是否加入了正确的工作电压 Check the meter L/+ and N/-whether the correct working voltage is added on the terminal
加信号后测量数据不准确或显示为 0 After adding the signal, the measurement data is not accurate or displayed as 0	电压测量不正确 Voltage measurement is wrong	检查电压信号是否正确接入设备 Check whether the correct voltage signal is added on the meter 检查电压测量信号是否在设备测量范围内 Check whether the voltage measuring signal is within the measuring range of the meter
	电流测量不准确 Current measurement is wrong	检查电流信号是否正确接入设备 Check whether the correct current signal is added on the meter 检查电流测量信号是否在设备测量范围内 Check whether the current measuring signal is within the measuring range of the meter
上位机不能与设备通讯 The upper computer cannot communicate with the meter	无通讯功能 No communication function	检查设备是否配有通讯功能 Check if the device is equipped with communication function
	通讯参数不正确 Communication parameters are incorrect	检查通讯地址是否正确 Check if the mailing address is correct 检查通讯波特率是否正确 Check if the communication baud rate is correct 检查通讯校验位是否正确 Check if the communication check digit is correct
	通讯链路受影响 Communication links are affected	检查同一个通讯链路上是否有相同参数的设备 Check if there is a device with the same parameters on the same communication link 检查通讯屏蔽层是否良好接地 Check that the communication shield is well grounded 检查通讯电缆是否断开 Check if the communication cable is disconnected

注：如果有一些无法解决的问题，请及时与我们公司的售后服务部门联系。

Note: If there are some problems that cannot be solved, please contact our after-sales service department in Time.

第六章 质量保证 Chapter VI Quality Assurance

6.1 质量保证 Quality Assurance

所有售给用户的新仪表，在通电运行后 12 个月或收到货后 18 个月内，对其因设计、材料和工艺引起的故障实行免费质量保证，如经认定产品符合上述质保条件，我公司负责免费维修。

All new instruments sold to users shall be guaranteed free quality for the design, materials and process within 12 months after power operation. If the products are determined to meet the above warranty conditions, our company shall be responsible for free maintenance.

6.2 质量限制 Quality limitation

以下装置的问题不属免费质保范围：

The following device issues are not free warranty:

- 由于不正确的安装、使用、存储引起的损坏。
- Damage caused by incorrect installation, use, and storage.
- 超出产品规定的非正常操作和应用条件。
- Beyond the abnormal operation and application conditions specified by the product.
- 由非本公司授权的机构或人修理了的仪表。
- Instruments repaired by agencies or persons not authorized by the Company..
- 超出免费质保年限了的仪表。
- Instruments beyond the free warranty period.

注：以上图片仅供参考，产品以实物为准。

Note: The above pictures are for reference only, and the product is subject to the physical object.



广东雅达电子股份有限公司

Guangdong Yada Electronics Co.,Ltd.

地址：广东省河源市高埔岗雅达工业园

Address:Yada industry park, Gaopugang, Heyuan city,

Guangdong Province.

国内业务 Domestic market: 86-762-3493871 3493872 3493873

国外业务 International market: 86-762-3496222

技术支持 Technical support: 86-762-3493926 3493989

传 真 Fax: 86-762-3493912 3493830

邮 编 Zip code: 517000

http: //www.yada.com.cn

E-mail: market@yada.com.cn

版权所有，保留一切权利。内容如有改动，恕不另行通知。

Copyright, all rights reserved. Specification subject to change without prior notice.