



NO: 13040901.0202.01

YD2040Y-F 系列多功能智能电力测控仪说明书

**YD2040Y-F Series of multi - functional smart power meter
specification**

**广东雅达电子股份有限公司
Guangdong Yada Electronics Co.,Ltd.**



危险和警告 Danger and warning

在进行安装、操作或者维护此设备之前，请仔细阅读本手册，通过本手册逐步熟悉设备。本文件不是一本适用于未受训者的操作手册，在其正常使用范围之外所引起的问题，本公司概不负责。

Before installing, operating or maintaining the equipment, please read this manual carefully, get it and gradually get familiar with the equipment. This document is not an operating manual for non-trainees, and our company are not responsible for any problems arising out of its normal use.



触电、燃烧或者爆炸的危险 Risk of electric shock, fire or explosion

- 本设备部分存在电力危险，请严格按照规范进行作业。

There is a power hazard in some parts of this equipment. Please operate in strict accordance with the specifications.

- 在维护和检修之前，设备必须断电并接地。

Before maintenance and overhaul, the equipment must be powered off and grounded.

- 在设备通电前，应将所有的机械部件，门和盖子等恢复原位。

All mechanical parts, doors and covers should be returned to their original position before the equipment is energized.

- 设备维护和安装工作只能由有资质的人员执行。

Equipment maintenance and installation work can only be performed by qualified personnel.

若不注意这些预防措施可能会引起严重伤害。

If you do not pay attention to these precautions, it may cause serious injury.

目 录 Contents

第一章 产品介绍 Chapter I Introduction	1
1.1 概述 General	1
1.2 功能介绍 Function.....	1
1.3 型号说明 Model Description	5
第二章 安装 Chapter II Installation	6
2.1 安装预防、准备 Installation prevention, preparation.....	6
2.2 安装信息 Installation Information	6
2.2.1 安装环境和位置 Installation environment and location.....	6
2.2.2 安装尺寸：盘面安装 Installation dimensions: Panel Mounting.....	7
2.2.3 安装方法 Installation method	7
2.3 端子定义 Terminal definition	8
2.4 接线图纸 Wiring drawing.....	8
2.4.1 电源 Power supply	9
2.4.2 电压电流 Voltage and Current.....	9
2.4.3 通讯 Communication	11
2.4.4 开关量输入 Digital input.....	12
2.4.5 继电器输出 Relay output.....	12
第三章 使用与操作 Chapter III Use and Operation	13
3.1 键盘定义 Keys definition.....	13
3.2 显示说明 Display.....	13
3.2.1 数据画面说明 Data screen Description.....	13
3.2.2 通讯、告警、DI、DO 画面 The screen of Communication, alarm, DI, DO.....	16
3.2.3 参数设置画面 The parameter setting screen	16
第四章 技术指标 Chapter IV Technical indicators	20
4.1 测量精度 Accuracy.....	20
4.2 环境条件和电源 Working conditions and Power supply.....	20
4.3 电压电流输入 Voltage and current input	20
4.4 开关量输入 Digital input	21
4.5 继电器输出 Relay output.....	21
4.6 通讯 Communication	21
4.7 电气特性 Electrical characteristics	21
4.8 电磁兼容 Electromagnetic compatibility.....	21

第五章 维护和故障排除 Chapter V maintenance and troubleshooting	23
5.1 故障排除 Troubleshooting	23
第六章 质量保证 Chapter VI Quality Assurance	24
6.1 质量保证 Quality Assurance	24
6.2 质量限制 The quality of limit	24

第一章 产品介绍 Chapter I Introduction

1.1 概述 General

YD2040Y-F系列智能表是一款集测量、监控、LCD显示、数字通信于一体的多功能智能测控仪，可广泛应用于智能建筑、电力系统、低压配电、工业自动化、能源管理系统及自动化等领域。

YD2040Y-F Series Smart meter is measurement, monitoring, LCD display and digital communication. It can be widely used in intelligent buildings, power systems, low-voltage power distribution, industrial automation, energy management systems and automation and other fields.

1.2 功能介绍 Function

表 1-1 基本功能
Table1-1 Base function

实时测量 Real-time measurement	
电流 Current	三相电流、零线电流 Three-phase current, zero sequence current
相电压 Phase voltage	三相电压 Three-phase voltage
线电压 Line voltage	三相线电压 Three-phase line voltage
有功功率 Active power	三相有功功率、三相总有功功率 Three-phase active power, three-phase total active power
无功功率 Reactive power	三相无功功率、三相总无功功率 Three-phase reactive power, three-phase total reactive power
视在功率 Apparent power	三相视在功率、三相总视在功率 Three-phase apparent power, three-phase total apparent power
功率因数 Power factor	三相功率因素、系统功率因素 Three-phase power factor, system power factor
频率 Frequency	系统频率 The system frequency
角度 Angle	三相电压与三相电流对应之间夹角、三相电压夹角、三相电流夹角 Angle between three-phase voltage and three-phase current, angle of three-phase voltage, angle of three-phase current
负载特性 Load characteristic	分相负载特性，合相负载特性（阻性、感性、容性） Split phase load characteristics, combined phase load characteristics (resistivity, sensibility, capacitance)
电能计量 Energy measuring	
电能 Energy	正向有功、反向有功、组合有功电能计量。 Positive active energy, reverse active energy and combined active energy measurement. 四象限无功、组合无功 1、组合无功 2 电能计量。 Four-quadrant reactive power, combined reactive power 1, combined reactive power 2 energy measurement. 正向视在、反向视在电能计量。 Positive and reverse apparent electric energy metering.

<p>复费率电能 Compound rate energy</p>	<p>分时有功、无功、视在电能计量功能，按相应的时段分别累计、存储总、尖、峰、平、谷电能。 Time-sharing active, reactive, and apparent energy metering functions, accumulating, storing total, sharp, peak, flat, and valley energy according to the corresponding time period. 年时段数最大为 14，每套时段表内最多有 8 个日时段表，日时段数最大为 14；时段最小间隔为 15 分钟，且应大于电能表内设定的需量周期；时段可以跨越零点设置。 The maximum number of time zones is 14, and there are up to 8 daily timetables in each timetable. The maximum number of time zones is 14; the minimum interval is 15 minutes, and should be greater than the demand cycle set in the energy meter; the time period can be crossed. Zero setting. 电能表内置两套时区表、两套日时段表，与之对应的还有两套时区表切换时间和两套日时段表切换时间。 The electric energy meter has two sets of time zone tables and two sets of daily timetables, and correspondingly two sets of time zone table switching time and two sets of daily timetable switching time. 两套时区表可以任意编程，并可设定两套时区表切换时间，定时在两套时区表之间切换。 The two sets of time zone tables can be programmed arbitrarily, and two sets of time zone table switching times can be set, and the timing is switched between the two sets of time zone tables. 两套日时段表可以任意编程，并可设定两套日时段表切换时间，定时在两套日时段表之间切换。 The two sets of daily timetables can be programmed arbitrarily, and two sets of daily timetable switching times can be set, and the timing is switched between the two sets of daily timetables.</p>
<p>电能质量 Power Quality</p>	
<p>谐波 Harmonic</p>	<p>各相电压 2~31 次谐波(分次谐波含量、总畸变率、奇次总畸变率、偶次总畸变率) Voltage 2~31 harmonics of each phase (gradual harmonic content, total distortion rate, odd total distortion rate, even total distortion rate) 各相电流 2~31 次谐波(分次谐波含量、总畸变率、奇次总畸变率、偶次总畸变率) Current 2~31 harmonics of each phase current (gradual harmonic content, total distortion rate, odd total distortion rate, even total distortion rate)</p>
<p>不平衡率 Unbalance rate</p>	<p>电压不平衡率、电流不平衡率 Voltage imbalance rate, current imbalance rate</p>
<p>统计 Statistics</p>	
<p>需量计量 Demand metering</p>	<p>正向有功功率、反向有功功率最大需量及发生时间。 Positive active power, reverse active power maximum demand and time of occurrence. 四象限无功功率，组合无功 1 功率、组合无功 2 功率最大需量及其出现的日期和时间。 Four-quadrant reactive power, combined reactive power, combined reactive power 2 maximum demand and its date and time of occurrence. 分时最大需量，总、尖、峰、平、谷有功、无功最大需量及其出现的日期和时间。 Time-sharing maximum demand, total, sharp, peak, flat, valley active, reactive maximum demand and its date and time of occurrence. 最大需量测量采用滑差方式，需量周期和滑差时间可设置。需量周期可在 5、10、15、30、60min 中选择；滑差式需量周期的滑差时间可以在 1、2、3、5min 中选择；需量周期应为滑差时间的 5 的整数倍。出厂默认值：需量周期 15min、滑差时间 1min。 The maximum demand measurement adopts the slip mode, and the demand period and slip time can be set. The demand period can be selected in 5, 10, 15, 30, 60min; the slip time of the slip type demand period can be selected in 1, 2, 3, 5 min; the demand period should be 5 of the slip time Integer multiple. Factory default: demand period 15min, slip time 1min. 总的最大需量测量应连续进行；各费率时段最大需量的测量应在相应的费率时段内完整的测量周期内进行。 The total maximum demand measurement shall be performed continuously; the measurement of the maximum demand for each rate period shall be performed within the complete measurement period of the corresponding rate period. 当发生电压线路上电、清零、时钟调整、时段转换、需量周期变更等情况时，电能表应从当前时刻开始，按照需量周期进行需量测量；在不完整的需量周期内，不做最大需量的记录。 When voltage line power-on, clear, clock adjustment, time period conversion, demand period change, etc. occur, the energy meter should start from the current time and measure the demand according to the demand period; in the incomplete demand period, Make the record of the largest demand.</p>

最大值 Maximum	三相电流、三相电压、功率需量最大值及其出现的日期和时间 Three-phase current, three-phase voltage, maximum power demand and the date and time of its occurrence
实时告警 Real-time alarm	
失压告警 Loss of pressure alarm	某相电流大于设定的失压事件电流触发下限（默认 0A），同时该相电压低于设定的失压事件电压触发上限（0V 不开启，默认 0V），且持续时间大于设定的失压事件判定延时时间（5~60 可设，默认 60s）。（三相三线情况下不判断 B 相失压） The phase current is greater than the set voltage loss event current trigger lower limit (default 0A), and the phase voltage is lower than the set voltage loss event voltage trigger upper limit (0V does not turn on, default 0V), and the duration is greater than the set loss. Pressure event determination delay time (setting range 5~60, default 60s). (The B phase loss is not judged in the case of three-phase three-wire)
过压告警 Overvoltage alarm	某相电压大于设定的过压事件电压触发下限（0V 不开启，默认 0V），且持续时间大于设定的过压事件判定延时时间（5~60 可设，默认 60s），（三相三线情况下不判断 B 相过压） A phase voltage is greater than the set over voltage event voltage trigger lower limit (0V does not turn on, default 0V), and the duration is greater than the set over voltage event decision delay time (setting range 5~60, default 60s). (Do not judge B-phase over voltage in the case of three-phase three-wire)
欠压告警 Undervoltage alarm	某相电压小于设定的欠压事件电压触发上限（0V 不开启，默认 0V），且持续时间大于设定的欠压事件判定延时时间（5~60 可设，默认 60s），（三相三线情况下不判断 B 相欠压） The phase voltage is less than the set under voltage event voltage trigger upper limit (0V is not on, the default is 0V), and the duration is greater than the set under voltage event determination delay time (setting range 5~60, default 60s). (Do not judge B-phase under voltage in the case of three-phase three-wire)
断相告警 Phase failure alarm	当某相电压低于设定的断相事件电压触发上限（0V 不开启，默认 0V），同时该相电流小于设定的断相事件电流触发上限（默认 0V），且持续时间大于设定的断相事件判定延时时间（5~60 可设，默认 60s）。（三相三线情况下不判断 B 相断相） When a phase voltage is lower than the set phase failure event voltage trigger upper limit (0V does not turn on, the default 0V), and the phase current is less than the set phase failure event current trigger upper limit (default 0V), and the duration is greater than the set Phase failure event determination delay time (setting range 5~60, default 60s). (The phase B phase is not judged in the case of three-phase three-wire)
失流告警 Loss of flow alarm	三相中至少有一相负荷电流大于失流事件电流触发下限（默认 0A），某相电压大于设定失流事件电压触发下限（默认 0V），同时该相电流小于设定的失流事件电流触发上限值（0A 不开启，默认 0A），且持续时间大于设定的失流事件判定延时时间（5~60 可设，默认 60s），（三相三线情况下不判断 B 相失流） At least one phase load current of the three phases is greater than the current trigger lower limit of the current loss event (default 0A), a phase voltage is greater than the set current interrupt event voltage trigger lower limit (default 0V), and the phase current is less than the set current loss event current. Trigger upper limit value (0A is not on, default 0A), and the duration is greater than the set outflow event determination delay time (setting range 5~60, default 60s). (B phase loss is not judged under three-phase three-wire condition)
过流告警 Overcurrent alarm	某相负荷电流大于设定的过流事件电流触发下限（0A 不开启，默认 0A），且持续时间大于设定的过流事件判定延时时间（5~60 可设，默认 60s），（三相三线情况下不判断 B 相过流） The load current of a phase is greater than the set current limit of the over current event (0A is not on, the default is 0A), and the duration is greater than the set over current event decision delay time (setting range 5~60, default 60s), B Phase is not judged to be over current in the case of three-phase three-wire condition)
断流告警 Cut off alarm	某相电压大于断流事件电压触发下限（默认 0V），同时该相电流小于设定的断流事件判定延时时间（5~60 可设，默认 60s），（三相三线情况下不判断 B 相断流） The voltage of a phase is greater than the lower limit of the voltage of the current interruption event (default 0V), and the phase current is less than the set current limit of the current interruption time (0A is not open, the default is 0A), and the duration is greater than the set current interruption event. Time (setting range 5~60, default 60s), (B phase failure is not judged in the case of three-phase three-wire)

过载告警 Overload alarm	在某相功率大于设定的过载事件有功功率触发下限 (0kW 不开启, 默认 0kW), 且持续时间大于设定的过载事件判定延时时间 (5~60 可设, 默认 60s), (不判断功率正负号, 三相三线情况不判断 B 相功率过载) In a phase power is greater than the set overload event active power trigger lower limit (0kW does not open, the default 0kW), and the duration is greater than the set overload event determination delay time (setting range 5~60, default 60s), (not judged Power positive and negative signs, three-phase three-wire condition does not judge B-phase power overload)
总功率因素超下限 Total power factor exceeds the lower limit	总功率因数小于设定的功率因素超下限阈值 (0 为不启用, 默认 0), 且持续时间大于设定的功率因素超下限判定延时时间 (5~60 可设, 默认 60s), (不判断功率因素正负号) The total power factor is less than the set power factor exceeds the lower threshold (0 is not enabled, the default is 0), and the duration is greater than the set power factor exceeds the lower limit decision delay time (setting range 5~60, default 60s) (not Determine the power factor plus or minus sign)
系统频率超下限告警 System frequency exceeding lower limit alarm	系统频率小于设定的系统频率超下限阈值 (0Hz 为不启用, 默认 0), 且持续时间大于设定的系统频率超下限判定延时时间 (5~60 可设, 默认 60s) The system frequency is less than the set system frequency and the lower limit threshold (0Hz is not enabled, the default is 0), and the duration is greater than the set system frequency and the lower limit decision delay time (setting range 5~60, default 60s)
系统频率超上限告警 System frequency exceeding upper limit alarm	系统频率大于设定的系统频率超上限阈值 (0Hz 为不启用, 默认 0), 且持续时间大于设定的系统频率超上限判定延时时间 (5~60 可设, 默认 60s) The system frequency is greater than the set system frequency and the upper limit threshold (0Hz is not enabled, the default is 0), and the duration is greater than the set system frequency and the lower limit decision delay time (setting range 5~60, default 60s)
DI 告警 DI alarm	DI 状态和 DI 告警极性一致, 且持续时间大于 DI 告警判定延时时间 (1~60 可设, 默认 1s), 默认不关联告警 The DI status is the same as the polarity of the DI alarm, and the duration is longer than the delay time for DI alarm determination (setting range 1~60, default 1s). By default, no alarm is associated
显示 Display	
实时数据 Real-time data	三相电压、电流、功率、频率等电参量 Three-phase voltage, current, power, frequency and other electrical parameters display 显示有功、无功电能显示 Active and reactive energy display
实时告警 Real-time alarm	告警信息提示 Alarm information prompt
设备参数 Device parameters	相关设定的参数 (通信参数如地址、波特率、校验方式和产品信息) Related set parameters (communication parameters such as address, baud rate, calibration method and product information)
显示设置 Display setting	液晶显示应在正常操作完成后 60S 内自动关闭背光显示 The LCD should be able to automatically turn off the backlight display within 60s after the normal operation is completed
历史数据存储 Historical data storage	
历史电量数据 Historical electricity data	月冻结数据, 冻结时刻默认每月 1 日 0 时, 冻结数据 (组合有功电能, 正向有功电能, 反向有功电能, 组合无功电能 1, 组合无功电能 2, 四象限无功电能, 正向视在电能, 反向视在电能, 分相总电能) 存储最近 12 个月历史电量 Freeze data for the month, freeze time defaults to 0:00 on the 1st of each month, freeze data (combined active energy, positive active energy, reverse active energy, combined reactive energy 1, combined reactive energy 2, four quadrant reactive energy, positive The apparent power is stored in the last 12 months for the apparent energy, reverse view energy, and split phase total energy)
日冻结数据 Daily frozen data	日冻结数据, 冻结时刻默认每日 0 时 0 分, 冻结数据 (正向有功电能, 反向有功电能, 组合无功电能 1, 组合无功电能 2, 四象限无功电能, 日冻结正向有功最大需量及发生时间, 日冻结反向有功最大需量及发生时间, 变量 (总、A、B、C 有功功率、总、A、B、C 相无功功率)) 存储最近 31 天历史电量 Daily freezing data, the default freezing time is 00:00 every day, freezing data (Positive active energy, reverse active energy, combined reactive energy 1, combined reactive energy 2, four quadrant reactive energy, Maximum daily freezing positive active energy demand and occurrence time, Maximum daily freezing positive reactive energy demand and occurrence time, Variables (Total, A, B, C active power, total, A, B, C phase reactive power) Store the historical power of the last 31 days)

第二章 安装 Chapter II Installation

2.1 安装预防、准备 Installation prevention, preparation

请在开始操作前阅读 Please read before starting the installation

本章包含重要的安全预防信息，在安装、服务或维护电气设备前必须遵守这些指导。仔细阅读并遵循下列安全预防指导。

This chapter contains important safety precautions that you must follow before installing, servicing, or servicing electrical equipment.

Read and follow the following safety precautions carefully.



电击，烧毁或爆炸的危险，所以只有合格的操作人员才能安装本设备。此工作应在阅读了该全部指导后开展。在进行安装，检验，测试或维护前，应断开所有的电源连接。请依照说明书中的接线说明接线，接完后要认真核对接线是否正确无误。意识到潜在的危险，工作人员需佩戴保护设备，仔细检查工作接线和安装是否正确。安装或者拆除仪表时，请确认电源、待测信号源及相关电源是否完成断开。



The danger of electric shock, fire or explosion, so that only qualified personnel can install the equipment. This work should be carried out after reading all of this guidance. In the visual inspection, testing or maintenance, should disconnect all power connection. Please follow the wiring instructions in the instructions and carefully check if the wiring is correct. Aware of the potential danger, workers need to wear protective equipment and carefully check the wiring and installation is correct. When installing or removing the meter, make sure the power supply, signal source to be measured and related power supply are completely disconnected.

2.2 安装信息 Installation Information

2.2.1 安装环境和位置 Installation environment and location

装置应安装在干燥、清洁、远离热源和强电磁场的地方，避免阳光直射。位置通常安装在开关柜中，可使装置不受油、污物、灰尘、腐蚀性气体或其他有害物质的侵袭。安装时要注意检修方便，有足够的空间放置有关的线、端子排、短接板和其他必要的设备。

The meter should be installed in dry, clean, away from heat and strong electromagnetic fields, avoid direct sunlight. The meter location is usually installed in the switch cabinet, which can protect the device from oil, dirt, dust, corrosive gas or other harmful substances.

During installation, please pay attention to the convenience of maintenance. There is enough space to place the relevant lines, terminal blocks, short boards and other necessary equipment.

2.2.2 安装尺寸：盘面安装 Installation dimensions: Panel Mounting

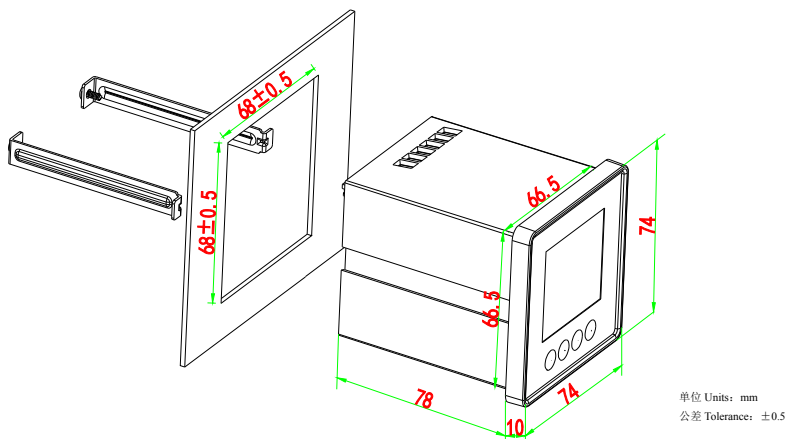

外形尺寸：长*宽*高 (74±0.5)mm*(74±0.5)mm*(88±0.5)mm 不包含接线端子

Dimension: L*W*H (74±0.5)mm*(74±0.5)mm*(88±0.5)mm No terminal is included

底壳尺寸：(66.5±0.5)mm*(66.5±0.5)mm

Bottom shell size: (66.5±0.5)mm*(66.5±0.5)mm

重量：约 0.327kg

Weight: About 0.327kg

2.2.3 安装方法 Installation method

- 1) 将仪表安装到尺寸为68±0.5mm×68±0.5mm的开孔。

Install the meter to the opening size of 68±0.5mm×68±0.5mm.

- 2) 将仪表卸去安装插销，从前向后推入盘面的安装孔。

Remove the meter from the mounting pin and push it from the front to the back.

- 3) 将安装插销顺着仪表两侧的插槽装上，并用螺丝打紧。

Install the mounting pins through the slots on both sides of the meter and tighten them with screws.

2.3 端子定义 Terminal definition

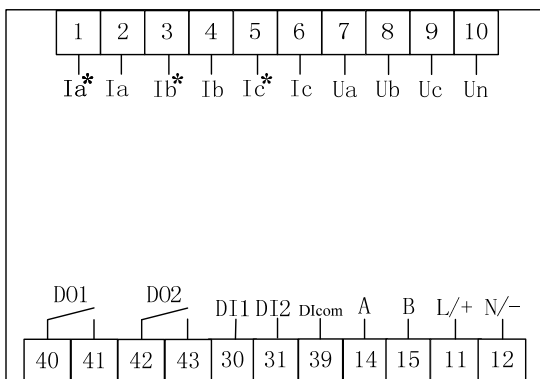

端子号 Terminal NO.	端子定义 Terminal definition	注释 Remark	端子号 Terminal NO.	端子定义 Terminal definition	注释 Remark
1	Ia*	A 相电流流入 A Phase current input	40、41	DO1	第一路继电器输出 The 1 st relay output
2	Ia	A 相电流流出 A Phase current output	42、43	DO2	第二路继电器输出 The 2 nd relay output
3	Ib*	B 相电流流入 B Phase current input	30	DI1	第一路开关量输入 The 1 st digital input
4	Ib	B 相电流流出 B Phase current output	31	DI2	第二路开关量输入 The 2 nd digital input
5	Ic*	C 相电流流入 C Phase current input	39	DIcom	开关量输入公共端 The common terminal of digital input
6	Ic	C 相电流流出 C Phase current output	14	A	RS485-A (MODBUS-RTU)
7	Ua	A 相电压输入 A Phase voltage input	15	B	RS485-B (MODBUS-RTU)
8	Ub	B 相电压输入 B Phase voltage input	11	L/+	交流电源火线/直流电源正极 Ac power supply live wire/DC power supply positive pole
9	Uc	C 相电压输入 C Phase voltage input	12	N/-	交流电源零线/直流电源负极 Ac power supply live wire/DC power supply positive negative
10	Un	零线电压输入 Zero line voltage input			

注：具体端子定义按实际型号相应增减。

Note: the specific terminal definition shall be subject to the actual product.

2.4 接线图纸 Wiring drawing



- 1) PT的二次侧不能短路;

The secondary measurement of PT cannot short-circuit;

- 2) CT的二次侧不能开路，在断开CT和监控回路连接时，将CT的二次侧短接；

The secondary measurement of CT cannot be opened. When the CT and monitoring loop are disconnected, the secondary measurement of CT should be shortened;

- 3) 装置适用于各种三相系统，请仔细阅读本章节，以选择合适的接线方式；

The device is suitable for all kinds of three-phase systems. Please read this chapter carefully to choose the appropriate wiring mode;

- 4) 接入的电压，应在装置的额定电压范围以内；

The voltage to be applied should be within the rated voltage range of the device;

- 5) PT一次侧必须有断路器或熔断器提供保护，如果使用的PT额定容量大于25VA，则PT二次侧也要装熔断器；

The PT must be protected by a circuit breaker or fuse., If the rated capacity of the PT used is greater than 25 VA, the PT secondary test shall also be equipped with a fuse;

- 6) PT和CT一次侧的励磁将在PT和CT二次侧电路产生较大的电压和电流，所以在安装仪表时一定要必要的安全措施，例如拆下PT的熔断器、短接CT二次侧。

The excitation of the PT and CT primary test will generate a large voltage and current in the PT and CT secondary test circuit, so necessary safety measures must be taken when installing the instrument, such as removing the PT fuse and short CT secondary test.

2.4.1 电源 Power supply

用于交流系统时，相线接L/+端，中性线接N/-端。电源范围AC85V~265V，50Hz/60Hz。

When used in AC system, the phase line is connected to the L/+ terminal, and the neutral line is connected to the N/- terminal. Power supply range AC85V~265V, 50Hz/60Hz.

用于直流系统时，正极接L/+端，负极接N/-端。电源范围DC20V~60V或DC100V~330V，具体参照铭牌标注信息。

When used in DC systems, the positive terminal is connected with L/+ terminal and the negative terminal is connected with N/-terminal. Power supply range is DC20V~60V or DC100V~330V, refer to the information marked on the nameplate.

2.4.2 电压电流 Voltage and Current

- 1) 三相四线接法 iring of three-phase four-wire

当测量线路为三相四线系统时，与互感器连接的导线都应有保护措施：空气开关或保险丝。接线示意图如下图所示。装置的接线方式应设为“三相四线”。

When the measuring line is a three-phase four-wire system, the wiring diagram is shown below, and the wiring mode of the device shall be set as "three-phase four-wire".

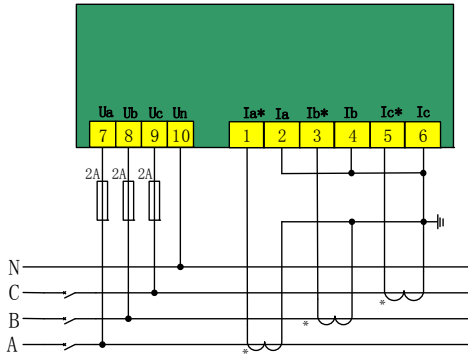

三相四线系统，无 PT,3CT Three-phase four-wire system, None PT,3CT

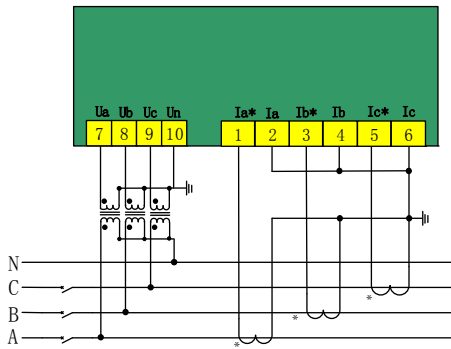

三相四线系统，3PT,3CT Three-phase four-wire system, 3PT,3CT

2) 三相三线接法 Wiring of three-phase three-wire

在这种接线方式下，接线示意图如下图所示。装置的接线方式应设为“三相三线”。

When the measuring line is a three-phase three-wire system, the wiring diagram is shown below, and the wiring mode of the device shall be set as "three-phase three-wire".

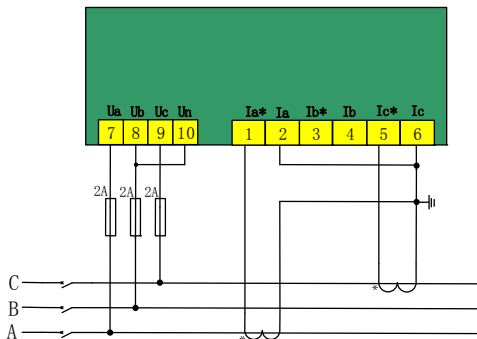

三相三线，无 PT,2CT Three-phase three-wire system, None PT,2CT

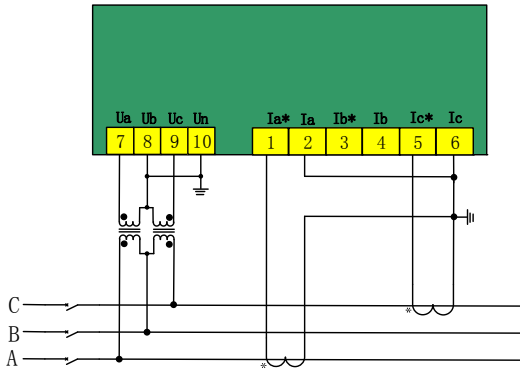

三相三线，2PT,2CT Three-phase three-wire system, 2PT,2CT

2.4.3 通讯 Communication

RS-485通信口，端子标记为A、B。

RS-485 communication port, the terminals are marked A and B.

RS-485 通信方式允许一条总线上最多接 32 台仪表，通过一个 RS-485 转换器与上位机连接。通信电缆可以采用普通的屏蔽双绞线，总长度不宜超过 1200 米，各个设备的 RS-485 口正负极性必须连接正确。如果屏蔽双绞线较长，建议在其末端接一个约 120Ω 的电阻以提高通信的可靠性。

The RS-485 communication mode allows up to 32 DCM series energy meters to be connected to one bus, and is connected to the host computer through an RS-485 converter. Communication cable can adopt ordinary screened twisted pair, and the total length shall be no more than 1200 meters, all RS-485 ports of positive and negative polarity must be connected correctly. If shielded twisted-pair cable is longer, suggestions on its end by one of about 120 Ω resistance in order to improve the reliability of communication.

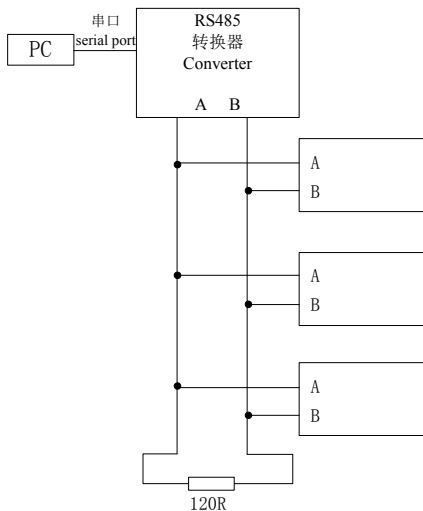

2.4.4 开关量输入 Digital input

装置选配 2 路开关量输入，端子标记为 DI1、DI2、DICom，用于检测外部接点的状态。装置内部有一个 12V 的直流自激电源，用于无源触点监测。显示上会显示 DI 相应的状态。

The device is equipped with 2-channel or 4-channel switching input, and the terminals are marked as DI1, DI2, DICom, which are used to detect the status of external contacts. There is a 12V dc self-excitation power supply inside the device for passive contact monitoring. The status of DI will be displayed.

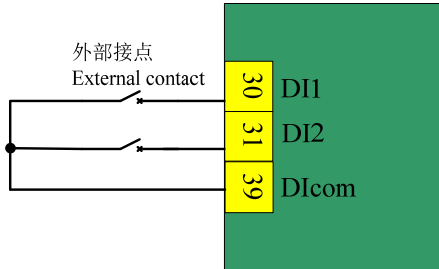

2.4.5 继电器输出 Relay output

装置选配 2 个电磁型继电器，端子排标记为 DO1、DO2，可直接切断 250VAC/5A 或 30VDC/5A 的负载。当负载电流较大时，建议增加中间继电器。

The device is equipped with 2 electromagnetic relays, whose terminal Banks are labeled DO1 and DO2, which can directly cut off the load of 250VAC/5A or 30VDC/5A. When the load current is large, it is recommended to add intermediate relay.

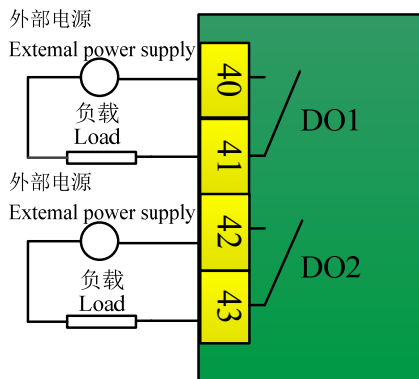



第三章 使用与操作 Chapter III Use and Operation

3.1 键盘定义 Keys definition

键盘有 4 个按钮组成，分别是 Bs  ,Up  ,Dn  ,St 

There are four keys,they are Bs  ,Up  ,Dn  ,St 

Bs  : 回到上一级画面，设置数据时：数据位右移，在谐波显示画面进入分次谐波显示界面。

Bs  : Go back to the upper screen, when setting data: the data bit is shifted to the right, and the harmonic display screen enters the Fractals harmonic display interface.

Up  : 画面向上切换，设置数据时：数据加一。

Up  : The screen switches up, when setting the data: the data plus one.

Dn  : 画面向下切换，设置数据时：数据减一。

Dn  : The screen switches down. When setting the data: the data minus one.

St  : 进入下一级画面，设置数据时：修改数据确认。

St  : Go to the next screen,When setting the data:Modified data validation.

3.2 显示说明 Display

3.2.1 数据画面说明 Data screen Description

显示界面主要由液晶显示屏和四个按钮组成，高亮背光显示，按键开启，无操作 60S 自动关闭背光。

The display interface is mainly composed of an LCD screen and four keys. The backlight display is highlighted with the keys on, while the backlight is automatically turned off when there is no operation 60S.



采用简体汉字，数据显示采用国家法定计量单位，如：kW、kvar、kWh、kvarh、V、A 等。电压 2 位小数、电流 2 位小数、功率 3 位小数、功率因数 3 位小数、电能显示 2 位小数。

Simplified Chinese characters are adopted, and national legal units of measurement are adopted for data display, such as kW, kvar, kWh, kvarh, V, A, etc. Voltage 2 decimal, current 2 decimal, power 3 decimal, power factor 3 decimal, power display 2 decimal.



电压 A 220.00 V Voltage B 220.00 V C 220.00 V	电压 AB 380.00 V Voltage BC 380.00 V CA 380.00 V 电能 Energy 8.00 kWh	A 5.00 A 电流 B 5.00 A Current C 5.00 A 电能 Energy 6.00 kWh
三相电压画面 The screen of three phase phase-voltage	三相线电压和组合有功电能画面 The screen of three phase line voltage and combined active energy	三相电流和反向总有功电能画面 The screen of three phase current and reverse total active energy
第一行: A 相相电压 The 1 st line: Phase-voltage of A phase	第一行: AB 相线电压 The 1 st line: AB phase line voltage	第一行: A 相电流 The 1 st line: A Phase current
第二行: B 相相电压 The 2 nd line: Phase-voltage of B phase	第二行: BC 相线电压 The 2 nd line: BC phase line voltage	第二行: B 相电流 The 2 nd line: B Phase current
第三行: C 相相电压 The 3 rd line: Phase-voltage of C phase	第三行: CA 相线电压 The 3 rd line: CA phase line voltage	第三行: C 相电流 The 3 rd line: C Phase current
	第四行: 组合有功电能 (正+反) The 4 th line: Combined active energy (positive + reverse)	第四行: 反向总有功电能 The 4 th line: Reverse total active energy
有功 A 1.100 kW Active B 1.100 k C 1.100 k 电能 Energy 4.00 kvarh	A 0.10 k 无功 B 0.10 kvar Reactive C 0.10 k 电能 Energy 2.00 kvarh	A 1.100 k B 1.100 k 视在 C 1.100 kVA Apparent power 15 - 07 - 27
有功功率和组合无功 1 电能画面 The screen of active power and combination reactive energy 1	无功功率和组合无功 2 电能画面 The screen of reactive power and combination reactive energy 2	视在功率和日期画面 The screen of apparent power and date
第一行: A 相有功功率 The 1 st line: A Phase active power	第一行: A 相无功功率 The 1 st line: A Phase reactive power	第一行: A 相视在功率 The 1 st line: A Phase apparent power
第二行: B 相有功功率 The 2 nd line: B Phase active power	第二行: B 相无功功率 The 2 nd line: B Phase reactive power	第二行: B 相视在功率 The 2 nd line: B Phase apparent power
第三行: C 相有功功率 The 3 rd line: C Phase active power	第三行: C 相无功功率 The 3 rd line: C Phase reactive power	第三行: C 相视在功率 The 3 rd line: C Phase apparent power
第四行: 组合无功 1 电能 (I 象限+II 象限+III 象限+IV 象限) The 4 th line: Combination reactive energy 1 (I quadrant + II quadrant + III quadrant + IV quadrant)	第四行: 组合无功 2 电能 (III 象限+IV 象限) The 4 th line: Combination reactive energy 2 (III quadrant + IV quadrant)	第四行: 年-月-日 The 4 th line: Year - month - day
有功 3.300 kW Active 无功 0.03 kvar Reactive 视在 3.310 kVA Apparent 14 = 38 = 20	A 1.000 PF B 1.000 C 1.000	总 Total 1.000 PF 频率 Frequency 50.000 Hz
总功率和时间画面 The screen of total power and time	功率因素画面 The screen of power factor	总功率因素、频率画面 The screen of total power factor and frequency
第一行: 总有功功率 The 1 st line: Total active power	第一行: A 相功率因素 The 1 st line: A phase power factor	第一行: 总功率因素 The 1 st line: Total power factor
第二行: 总无功功率 The 2 nd line: Total reactive power	第二行: B 相功率因素 The 2 nd line: B phase power factor	
第三行: 总视在功率 The 3 rd line: Total apparent power	第三行: C 相功率因素 The 3 rd line: C phase power factor	第三行: 频率 The 3 rd line: Frequency
第四行: 时=分=秒 The 4 th line: Hour=Minute=Second		

-t1- 电能 Energy 100.00kWh	-t2- 电能 Energy 100.00kWh	-t3- 电能 Energy 100.00kWh
组合有功尖时段电能画面 The screen of combined active energy flat period	组合有功峰时段电能画面 The screen of combined active energy peak period	组合有功平时段电能画面 The screen of combined energy peak period
第四行：组合有功尖时段电能 The 4th line: Combined active energy sharp period	第四行：组合有功峰时段电能 The 4th line: Combined active energy peak period	第四行：组合有功平时段电能 The 4th line: Combined active energy peak period

-t4- 电能 Energy 100.00kWh	电压 A 1.00 % B 2.00 % 畸变率 Distortion rate C 3.00 % 2.00	A 1.00 % 电流 B 2.00 % 畸变率 Distortion rate C 3.00 % 2.00
组合有功谷时段电能画面 The screen of combined active energy valley period	总谐波电压畸变率 Total harmonic voltage wave distortion rate	电流总谐波畸变率 Total harmonic current wave distortion rate
	第一行：A 相电压总谐波畸变率 The 1 st line: Total harmonic voltage wave distortion rate of A phase	第一行：A 相电流总谐波畸变率 The 1 st line: Total harmonic current wave distortion rate of A phase
	第二行：B 相电压总谐波畸变率 The 2 nd line: Total harmonic voltage wave distortion rate of B phase	第二行：B 相电流总谐波畸变率 The 2 nd line: Total harmonic current wave distortion rate of B phase
	第三行：C 相电压总谐波畸变率 The 3 rd line: Total harmonic voltage wave distortion rate of C phase	第三行：C 相电流总谐波畸变率 The 3 rd line: Total harmonic current wave distortion rate of C phase
第四行：组合有功谷时段电能 The 4th line: Combined active energy valley period	第四行：平均电压总谐波畸变率 The 4th line: Average Total harmonic voltage wave distortion rate	第四行：平均电流总谐波畸变率 The 4th line: Average Total harmonic current wave distortion rate

数据画面在客户无按键操作时，所有画面进行轮显，也可以通过按键 Up 键“”和 Dn 键“”实现手动切换。

When the data screen is operated without buttons by the customer, all the screens are displayed in wheel show, and manual switching

can also be achieved by pressing Up key”” and Dn key”.

分次谐波显示画面 Ordered harmonic display screen

电压 A 1.00 % Voltage B 2.00 % 畸变率 Distortion rate C 3.00 % 2	A 1.00 % 电流 B 2.00 % 畸变率 Distortion rate C 3.00 % 2	
电压分次谐波畸变率 Voltage fractional harmonic distortion rate	电流分次谐波畸变率 Current fractional harmonic distortion rate	
第一行：A 相电压分次谐波畸变率 The 1 st line: Voltage fractional harmonic distortion rate of A phase	第一行：A 相电流分次谐波畸变率 The 1 st line: Current fractional harmonic distortion of A-phase	
第二行：B 相电压分次谐波畸变率 The 2 nd line: Voltage fractional harmonic distortion rate of B phase	第二行：B 相电流分次谐波畸变率 The 2 nd line: Current fractional harmonic distortion of B-phase	

第三行: C相电压分次谐波畸变率 The 3 rd line: Voltage fractional harmonic distortion rate of C phase	第三行: C相电流分次谐波畸变率 The 3 rd line: Current fractional harmonic distortion of C-phase	
第四行: 分次序号 The 4th line: Sort number	第四行: 分次序号 The 4th line: Sort number	

3.2.2 通讯、告警、DI、DO 画面 The screen of Communication, alarm, DI, DO

电压 Voltage	A	220.00	V
	B	220.00	V
	C	220.00	V
通讯 Communication	告警 Alarm	DI1 DI2	DO1 DO2

a、当产品通讯正常，在屏幕左下方会显示通讯字样：

When the product communication is normal, the word communication will be displayed at the bottom left of the screen;

b、当系统产生任何一个告警，在屏幕左下方会显示告警字样：

When the system generates any alarm, the word “Alarm” will be displayed at the bottom left of the screen;





c、当产品开关量输入 DI1 闭合，则在显示最下方会显示 DI1 字样，开关量输入 DI2 闭合，显示最下方会显示 DI2 字样：





When the product digital input DI1 is closed, the word "DI1" will be displayed at the bottom of the display, and the word "DI2" will be displayed at the bottom of the display;

d、当产品继电器输出 DO1 闭合，在显示右下角显示 DO1 字样，继电器输出 DO2 闭合，在显示右下角显示 DO2 字样：

When the product relay outputs DO1, the word DO1 will be displayed in the bottom right corner of the display, and the relay outputs DO2, the word DO2 will be displayed in the bottom right corner of the display.

3.2.3 参数设置画面 The parameter setting screen

在任何数据画面点击 St 键 “” 进入参数设置画面,可查看通讯参数、PTCT 参数、版本信息等信息，如需更改参数则点击 St 按键 “” 并输入密码 2000，在设置画面输入密码后则可以更改参数，退出参数设置画面后再次进入参数设置画面设置参数需重新输入密码，未退出设置画面则不再再次输入密码;清除电能和需量清零则点击设 St 按键 “” 并输入密码 3366；参数设置画面点击 Bs 键 “” 返回数据画面。在参数设置界面，无按键操作 60 秒后自动退出到测量画面，未确认数据不保存。

Click St Key“” in any data screen to enter the parameter setting screen. You can view the communication parameters, PTCT parameters, version information and other information.To change parameters, click the St “”and enter the password 2000.After entering the password in the setting screen, you can change the parameters. After exiting the parameter setting screen, you can enter the parameter setting screen again. To set parameters, you need to input the password again.Do not exit the setting screen, do not enter the password again; Then click the set St“” button and enter the password 3366; Click "Bs"  to return the data screen.In the parameter setting interface, it will automatically exit to the measurement screen after 60 seconds of no key operation, and the data will not be saved if not confirmed.

输入密码示例 Sample password input:

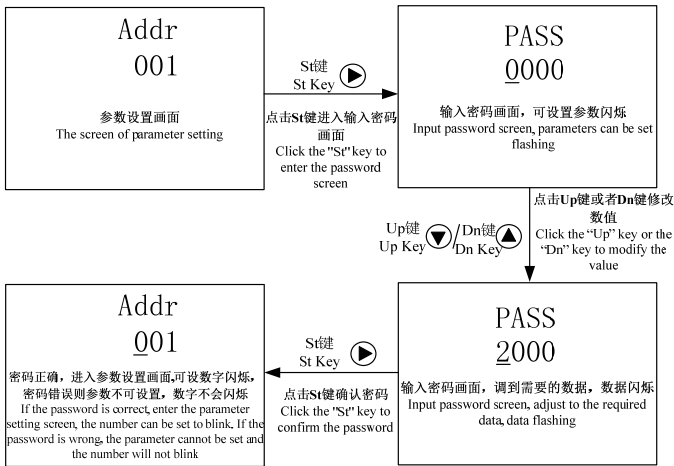

3.2.3.1 参数设置目录 Parameter setting content



任意测量数据画面按 “  ” 键一次，固定进入设置参数画面。

Press "  " button once for any measurement data screen, and enter the setting parameter screen.

Addr 001	bAUd 9600 nonE	Pt1 00001
通讯地址 Communication address	通讯波特率，校验位 Communication baud rate, check Digit nonE: 无检验, EvEn: 偶检验, nonE: No, EvEn: Even odd: 奇校验 odd: Odd	电压变比 1 Pt1 可设值 1~50000 Can set value 1~50000
Pt2 00001	Ct 00001	SySt 3P4L
电压变比 2 Pt2 可设值 1~50000 Can set value 1~50000	电流变比 Ct 可设值 1~50000 Can set value 1~50000	系统选择 System selection 3P4L: 三相四线, 3P3L: 三相三线 3P4L: Three-phase four-wire, 3P3L: Three phase three wire

CLr-E 0000	CLr-d 0000	vEr 2. 0. 00 F1
清除电能 Remove energy 密码: 3366 Password: 3366	清除需求量 Clear demand 密码: 3366 Password: 3366	产品信息 Product information

它们之间画面切换通过按键 Up 键 “” 和 Dn 键 “” 实现，按 St 键 “” 进入密码画面，若已经输入过密码则直接进入数字闪烁画面。

The screen switch between them is realized by pressing Up key "" and Dn key "". Press St key "" to enter the password screen. If the password has been entered, it will enter the digital flashing screen directly.

3.2.3.2 参数设置示范 Example of parameter setting

1) 地址设置 Address setting

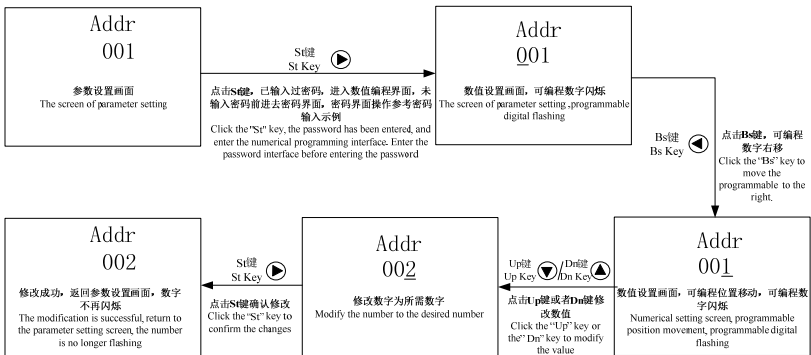

2) 校验位设置 Check digit setting

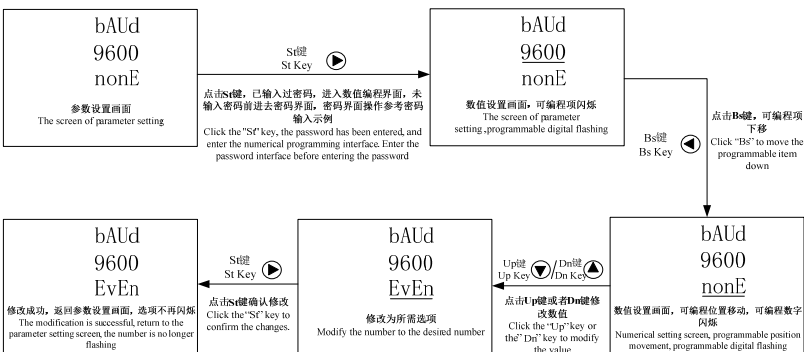

3) 清除电能 Clear energy

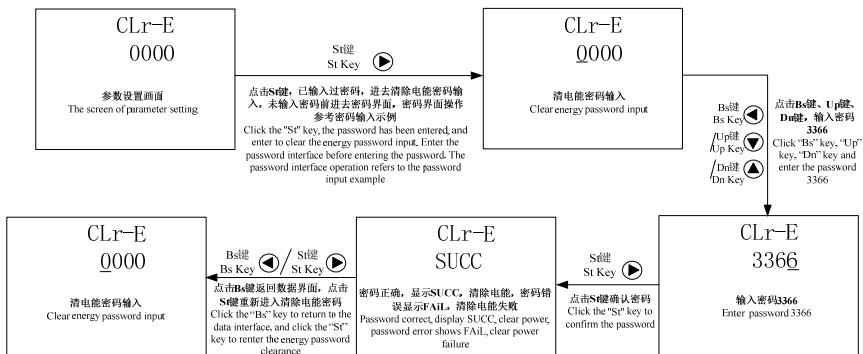

第四章 技术指标 Chapter IV Technical indicators

4.1 测量精度 Accuracy

参数 Parameter	精度 Accuracy	测量范围 Measuring range
电流 Current	0.5 级 0.5 Class	AC0.05A~6A
相电压 Phase voltage	0.5 级 0.5 Class	AC20V~400V
频率 Frequency	±0.02Hz	45Hz~65Hz
功率 Power	0.5 级 0.5 Class	
功率因数 Power factor	0.5 级 (视在功率大于 6W) 0.5Class (Apparent power is greater than 6W)	0±1.0
电能 Energy	0.5S 级、1 级 0.5SClass、1Class	

4.2 环境条件和电源 Working conditions and Power supply

环境条件 Working conditions		
储藏温度: -40℃~+70℃ Storage temperature: -40℃~+70℃	工作温度: -10℃~50℃ Working temperature: -10℃~50℃	
湿度: 20%~95% Humidity: 20%~95%	极限温度: -20℃~55℃ The limit working temperature: -20℃~55℃	
工作电源 Power supply		
最大功耗 Maximum power consumption	4W	输入: DC20V~60V 或 AC85V~AC265V, 50/60Hz 或 DC100V~DC330V 具体参照铭牌标注信息: Input: DC20V~60V or AC85V~AC265V, 50/60Hz or DC100V~DC330V refer to the information marked on the nameplate.

4.3 电压电流输入 Voltage and current input

相电压输入 Phase voltage input		
额定电压 Rated voltage	AC3*220/380V; AC3*380V	负荷: 小于 0.2VA Line loss per phase: ≤0.2VA
	AC3*57.7/100V; AC3*100V	测量范围: AC20V~400V Measuring range: AC20V~400V
电流输入 Current input		
额定电流: AC3*5(6)A Rated current: AC3*5(6)A	负荷: 小于 0.5VA Line loss per phase: <0.5VA	
测量范围: AC0.05A~6A Measuring range: AC0.05A~6A	过负荷: 2 倍额定电流连续 Overload: 2 times rated current continuous	

备注：超过产品额定范围的电压/电流值会造成仪表损坏。长时间满量程应用也会对您的设备造成损坏。我公司对于超量程导致的精度变化不予负责。

Note: voltage/current exceeding the rated range of the product may cause instrument damage. Long full range applications can also cause damage to your equipment. Our company is not responsible for the accuracy change caused by overrange.

4.4 开关量输入 Digital input

开关量输入 Digital input	
光耦隔离 Optical coupling isolation	输入类型：无源点 Input mode: Passive point

4.5 继电器输出 Relay output

继电器输出 Relay output	
接点容量：AC250V, 5A (阻性)；DC30V, 5A Contact capacity: AC250V, 5A (Resistive) or DC30V, 5A	输出方式：电平或脉冲输出，默认电平输出 Output mode: Level or pulse output, default level output
接点形式：常开 Contact form: Normally open	

4.6 通讯 Communication

MODBUS 通讯协议 MODBUS Communication protocol	
通讯端口：RS485 2 线 半双工 Communication port: RS485,2-wire half-duplex	通讯波特率：1200bps、2400bps、4800bps、9600bps 可选 Baud rate: 1200bps、2400bps、4800bps、9600bps Optional
校验位：无/奇/偶 Check bit: odd / even / none Optional	

4.7 电气特性 Electrical characteristics

电气特性 Electrical characteristics	
绝缘电阻：100MΩ/500V Insulation resistance: 100MΩ/500V	介质强度（工频耐压） Dielectric strength (power frequency withstand voltage) : 2kv (r.m.s) , 50Hz, 1min (电压、电流、电源、DO 端口)、1kv (r.m.s) , 50Hz, 1min (DI 输入、RS485 端口) 2kv (r.m.s), 50Hz, 1min (Voltage、Current、Power supply、DO port)、1kv (r.m.s), 50Hz, 1min (DI input、RS485port)

4.8 电磁兼容 Electromagnetic compatibility

电磁兼容 Electromagnetic compatibility	
电快速瞬变脉冲群抗扰度试验 Electrical fast burst immunity	执行标准 GB/T 17626.4；IEC 61000-4-4 Execution standard GB/T 17626.4; IEC 61000-4-4 等级：IV级（通信端口 2kV，其它端口 4kV） Class: IV Class (Communication port 2kV, Other ports 4kV)

静电放电抗扰度试验 Static immunity	执行标准 GB/T 17626.2; IEC 61000-4-2 Execution standard GB/T 17626.2; IEC 61000-4-2 等级: III级 (接触放电6kV, 空气放电8kV) Class: III Class (Contact Discharge 6kV, Air Discharge 8kV)
浪涌(冲击)抗扰度试验 Surge immunity	执行标准 GB/T 17626.5; IEC 61000-4-5 Execution standard GB/T 17626.5; IEC 61000-4-5 等级: IV级 (电压、电流、电源、DO 端口 4kV, DI 输入、RS485 端口 1kV) Class: IV Class (Voltage, current, power supply, DO port 4kV, DI input, RS485 port 1kV)
射频电磁场辐射抗扰度试验 Rf electromagnetic radiation immunity test	执行标准 GB/T 17626.3; IEC 61000-4-3 Execution standard GB/T 17626.3; IEC 61000-4-3 等级: III级 (10V/m) Class: III Class (10V/m)

第五章 维护和故障排除 Chapter V maintenance and troubleshooting

5.1 故障排除 Troubleshooting

可能问题 Possible problems	可能原因 Possible cause	可能解决方案 Possible solution
上电后无显示 No display after power-on	电源未能加入到设备上 The power supply is not added to the meter	检查设备 L/+ 和 N/- 端子上是否加入了正确的工作电压 Check the meter L/+ and N/- whether the correct working voltage is added on the terminal
加信号后测量数据不准确或显示为 0 After adding the signal, the measurement data is not accurate or displayed as 0	电压测量不正确 Voltage measurement is wrong	检查电压信号是否正确接入设备 Check whether the correct voltage signal is added on the meter 检查电压测量信号是否在设备测量范围内 Check whether the voltage measuring signal is within the measuring range of the meter 检查 PT 变比参数是否设置正确 Check whether the PT ratio parameter is set correctly
	电流测量不准确 Current measurement is wrong	检查电流信号是否正确接入设备 Check whether the correct current signal is added on the meter 检查电流测量信号是否在设备测量范围内 Check whether the current measuring signal is within the measuring range of the meter 检查 CT 变比参数是否设置正确 Check whether the CT ratio parameter is set correctly
	功率测量不准确 Power measurement is wrong	检查测量模式设置是否正确 Check that the measurement mode Settings are correct 检查电压电流对应相序是否正确 Check whether the phase sequence of voltage and current is correct 检查电流方向是否正确 Check whether the current direction is correct
开关量状态不变化 Switching state does not change	开关量输入错误 Digital input error	检查设备是否配有开关量输入功能 Check whether the meter is equipped with digital input function 检查外部接线是否正确 Check if the external wiring is correct
继电器不动作 Relay non-action	没有接收到控制命令 Control command not received	检查相关设置是否正确（在哪种模式下） Check if the Settings are correct (in which mode) 若是通讯控制，检查通讯是否成功 If communication controls are available, check that the communication is successful
	无继电器功能 No relay function	检查设备是否配有继电器功能 Check whether the meter is equipped with relay function
上位机不能与设备通讯 The upper computer cannot communicate with the meter	无通讯功能 No communication function	检查设备是否配有通讯功能 Check whether the meter is equipped with communication function
	通讯参数不正确 Communication parameters are incorrect	检查通讯地址是否正确 Check if the communication address is correct 检查通讯波特率是否正确 Check if the communication baud rate is correct 检查通讯校验位是否正确 Check if the communication check bit is correct
	通讯链路受影响 Communication links are affected	检查同一个通讯链路上是否有相同参数的设备 Check if there is a meter with the same parameters on the same communication link 检查通讯屏蔽层是否良好接地 Check that the communication shield is well grounded 检查通讯电缆是否断开 Check if the communication cable is disconnected

注：如果有一些无法解决的问题，请及时与我们公司的售后服务部门联系。

Note: If there are some problems that cannot be solved, please contact our after-sales service department in time.

第六章 质量保证 Chapter VI Quality Assurance

6.1 质量保证 Quality Assurance

所有售给用户的新仪表，在通电运行后 12 个月或收到货后 18 个月内，对其因设计、材料和工艺引起的故障实行免费质量保证，如经认定产品符合上述质保条件，我公司负责免费维修。

All new meters sold to customers shall be provided with free quality assurance for the faults caused by design, materials and process within 12 months after power-on or 18 months after receiving the goods. If the products are determined to meet the above quality guarantee conditions, our company shall be responsible for free maintenance.

6.2 质量限制 The quality of limit

以下装置的问题不属免费质保范围：

Problems with the following devices are not covered by free warranty:

- 由于不正确的安装、使用、存储引起的损坏。

Damage due to incorrect installation, use, and storage.

- 超出产品规定的非正常操作和应用条件。

Excessive operating and application conditions beyond the product specifications.

- 由非本公司授权的机构或人修理了的仪表。

The meter that has been repaired by an organization or person that is not authorized by the company.

- 超出免费质保年限了的仪表。

The meter that exceeds the free warranty period.

注：以上图片仅供参考，产品以实物为准。

Note: The above pictures are for reference only, the products are subject to the actual product.



广东雅达电子股份有限公司

Guangdong Yada Electronics Co.,Ltd.

地址：广东省河源市高埔岗雅达工业园

Address:Yada industry park, Gaopugang, Heyuan city,
Guangdong Province.

国内业务 Domestic market: 86-762-3493871 3493872 3493873

国外业务 International market: 86-762-3496222

技术支持 Technical support: 86-762-3493926 3493989

传 真 Fax: 86-762-3493912 3493830

邮 编 Zip code: 517000

http: //www.yada.com.cn

E-mail: market@yada.com.cn

版权所有，保留一切权利。内容如有改动，恕不另行通知。

Copyright, all rights reserved. Specification subject to change without prior notice.